

Part 1 General Information

- 1. Midea Product Development History..... 2
- 2. DC Inverter V4+ K Series Introduction 2
- 3. Model Lineup 8
- 4. Units Combination Table 9
- 5. Indoor Units Lineup 10
- 7. Nomenclature 12

Part 1 General Information

1. Midea Product Development History

In 1999, Midea cooperated with Toshiba, produced the first AC inverter VRF.

In 2001, Midea produced the first VRF in air-conditioning industry.

In 2002, Midea produced the first AC Inverter VRF and D series VRF in China.

In 2003, Midea completed the 2nd D series and 2nd V series VRF.

In 2005, Midea cooperated with Hitachi, produced the first module's AC Inverter V3 and digital scroll D3.

In 2005, Midea cooperated with IR Company, founded united lab.

In 2008, Midea produced the V4, which is the R410A DC inverter VRF and modular design also.

In 2010, the new V4+ was on sale, which owns the entire DC inverter technology and new low noise technology.

In 2011, Midea produced the heat recovery VRF.

In 2012, the V4+ K series was on sale, with the largest capacity up to 72HP.

2. DC Inverter V4+ K Series Introduction

2.1 Free combination, the largest capacity 72HP

V4+ K series achieves the largest capacity of 72HP by combining maximum 4 outdoor units with 6 different capacities (8, 10, 12, 14, 16 and 18HP), and up to 64 indoor units can be connected in one refrigeration system.

2.2 High efficiency and Energy-saving:

V4+ K realized the industry's top class energy efficiency by adoption of Brushless Reluctance DC compressor control, all DC fan motor and improved heat exchanger.

2.2.1 High efficiency DC inverter compressor, saving power 25%

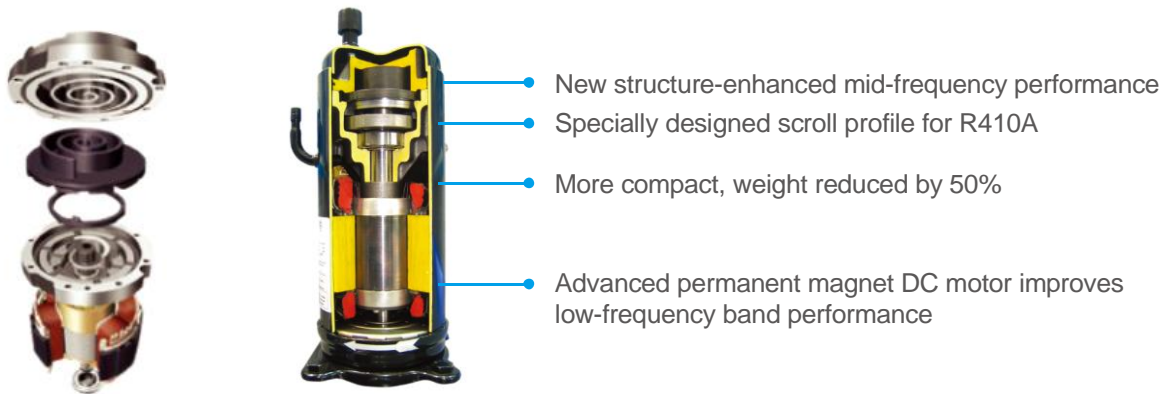

Powerful magnets provide high torque and efficiency and achieve 70% reduction in volume.

The A/C load ratio of building is 30%-75%, the area use ratio is 55%, most of the A/C runs in the mid load, so the mid load operation ratio determines the whole year AC running charge.

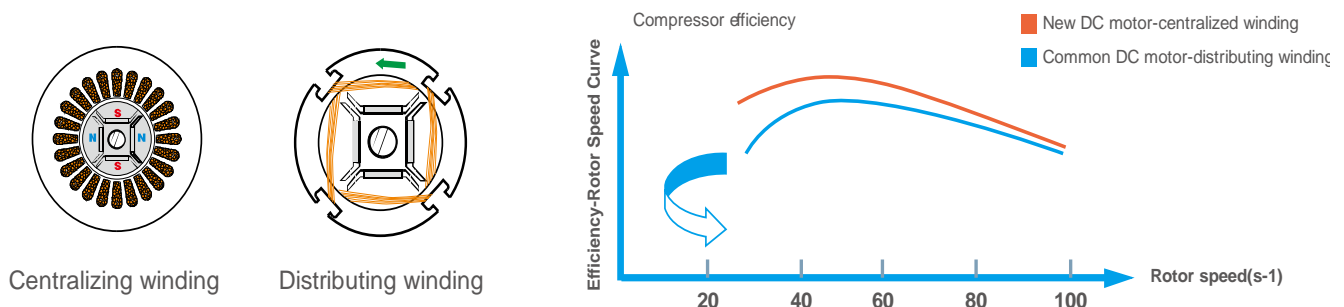

Smooth sine wave DC inverter

Adopting the 180° sine wave inverter to smooth motor rotation greatly improves operating efficiency compared with traditional sawtooth wave.

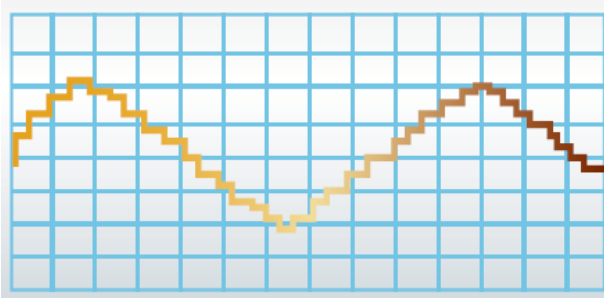

Common sawtooth wave

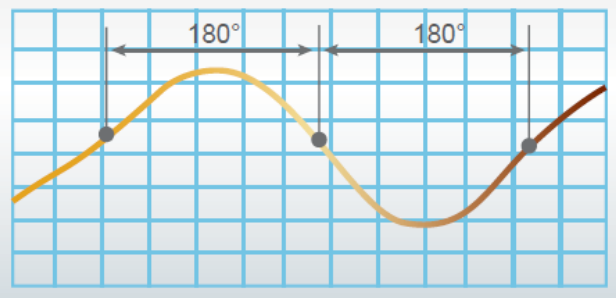

180° Sine Wave DC inverter



8HP&10HP units adopt only one DC Inverter Compressor, offer a high efficiency and energy saving solution.

12,14,16,18HP units adopt a high capacity DC inverter compressor and a fixed compressor combination.

2.2.2 High efficiency DC fan motor, saving power 50%

According to the running load and pressure, it controls the speed of DC fan to achieve the minimum energy consumption, to reach the best effect.

- Used across entire range of models (from 8 to 72 HP).
- Efficiency improved up to 45% especially at low speed.



Pressure sensor

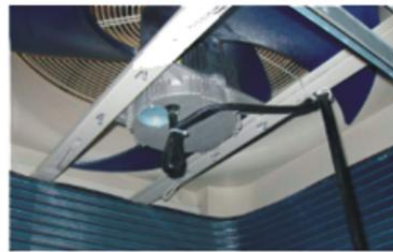

DC fan motor

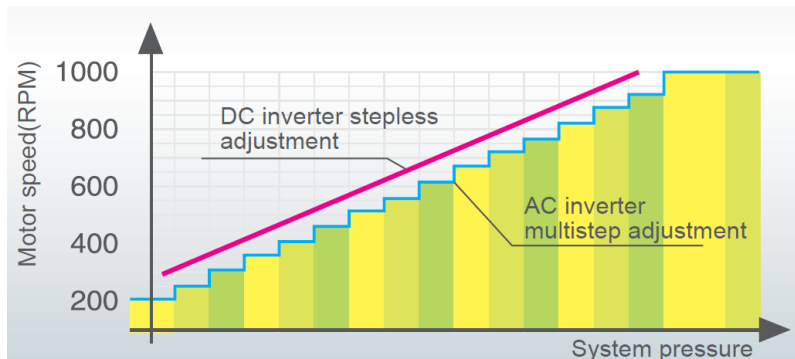

The fluctuation range of motor rotor speed is within ±5 rpm and the motor can rapidly match the output of DC inverter compressor. The efficiency is enhanced under part load.

2.2.3 Optimize heat exchange design, heat exchange efficiency increased by 10%

12°C sub-cooling degree makes the cooling capacity increased efficiently. Innovative designed outdoor high efficiency heat exchanger can reach up to 12°C sub-cooling degree one time, reduces the system resistance and improves reliability.

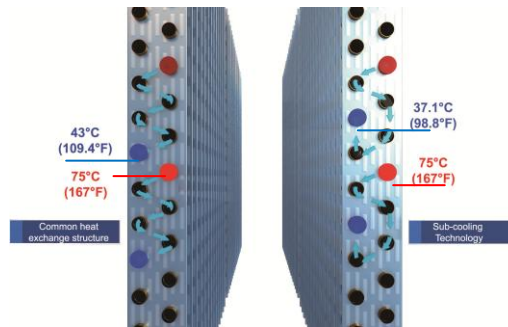

2.3 More flexible design

2.3.1 External static pressure enhanced up to 60 Pa and air volume increased by 10%.

The high-static pressure propeller and optimized fan guard can adapt to various installation environments.

Midea now offers up to 40 Pa* external static pressure units for customized applications (60 Pa is available for the 12HP model). A standard 0-20Pa function is equipped by default.

*You need to consult Midea if you require over 40Pa.



2.3.2 More options of indoor units and high capacity connection

Lineup of heat pump types is 8 to 72 HP. Indoor units consist of 14 types with more than 100 models, capacity range from 1.8kW to 56kW. A maximum 130% indoor units' connective ratio is allowed for all capacities of outdoor unit. This wide selection of models makes it possible to build a system that suits the customer's requirements.

2.4 High Comfort

2.4.1 Optional outdoor units Silent Mode control

Night silent operation will be activated X (6, 8) hours after the peak temperature during daytime, and it will get back to normal operation after Y (8,10,12) hours. To run in lower speed, lower noise, min. **46.8dB (A)**

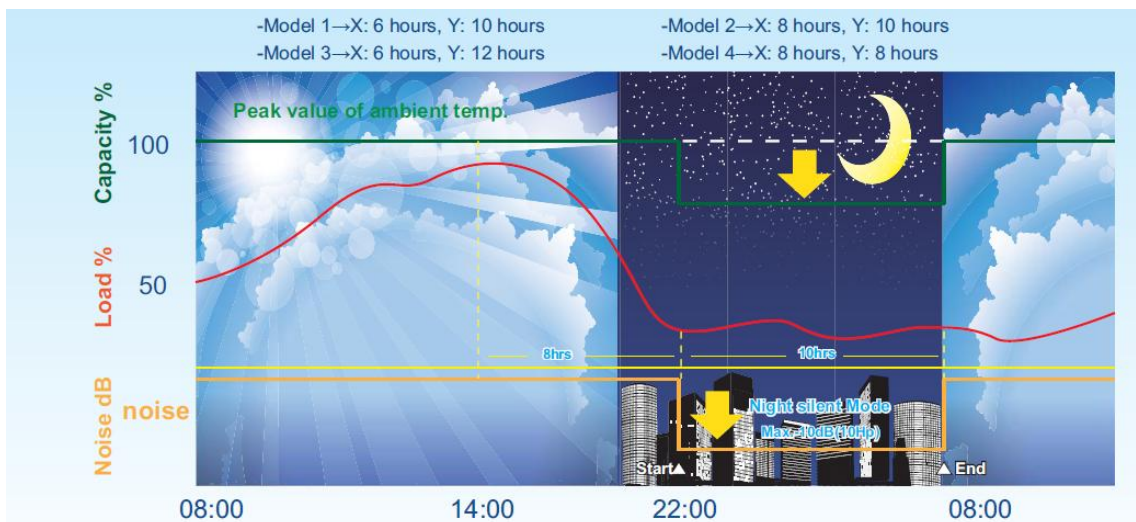

2.4.2 More Options for outdoor units

Night silent mode, silence mode, super silence mode.

2.5 High Reliability

2.5.1 Alternative Cycle Duty operation of outdoor units

In one combination, any outdoor unit can run as the master outdoor unit to equalize the service life of all units.

Take 48HP system for example.

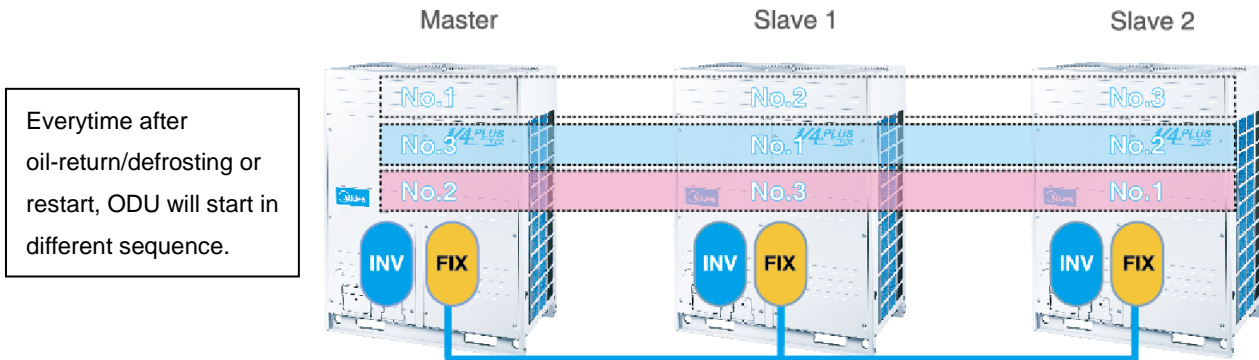

2.5.2 Back-Up operation function

In a multiple system, when the master unit failed, any single unit can be set as the master unit, then the remaining units can keep on working. This can be set on PCB by DIP switches at site.

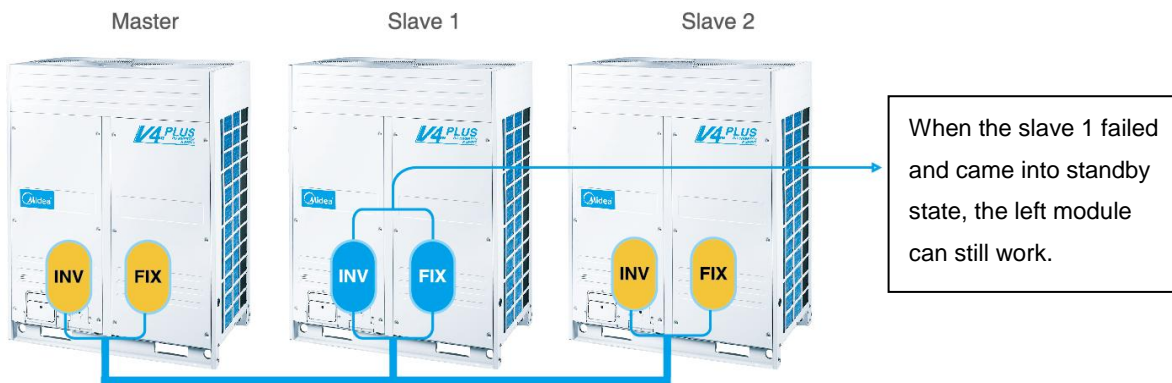

2.5.3 Dynamic gas balance technology

Dynamic vector balance technology, no need to install gas balance pipe:

- High-precision pressure sensor monitors the system pressure on time and transfers the data to master unit.
- Master unit sends the pressure data to every unit and make sure each outdoor unit is in balance situation.

2.5.4 High efficiency oil balance technology

Oil balance pipes among modules and individual oil balance by vector control ensure even oil distribution among the modules which keeps compressors running normally.

High efficiency centrifugal oil separators (separation efficiency up to 99%) make oil separate from discharge gas and go back to compressors.

Auto oil return program by monitoring the running time and state of system ensures reliable oil return.

Oil balance diagram:

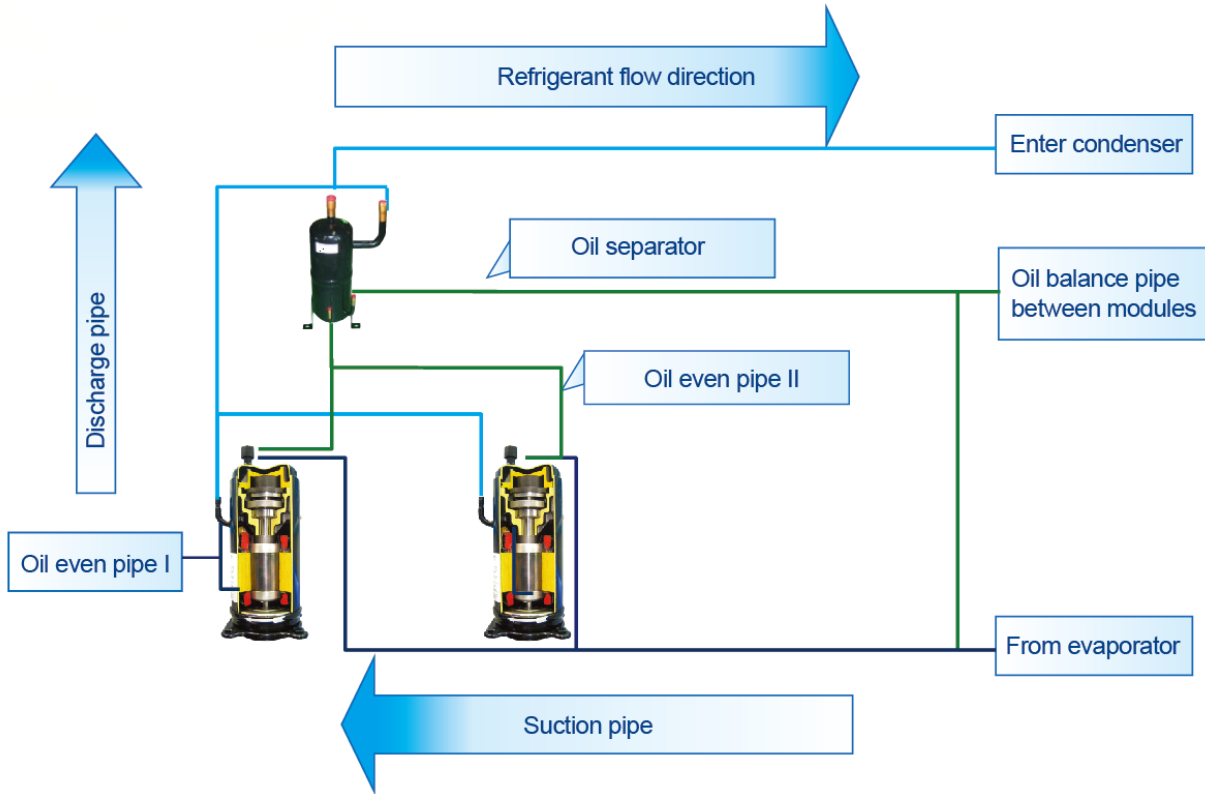

2.5.5 Oil return technology

Centrifugal oil separator can be up to over 99% separating efficiency, which in time and efficiently send the oil to compressors to ensure compressor oil volume.

System auto back oil design can complete through PC core send oil back instruction by system running time and state.

The accumulator is large volume design, which can more save refrigerant to avoid liquid strike.

Multi back oil holes can ensure compressor smooth back oil.

2.5.6 Intelligent soft start technology, rapidly enhance refrigerant cycle volume

Compressor soft start complete low frequency and low current start by DC inverter compressor, and to reduce strike to electric network. When start DC inverter compressor, system runs in large volume and offer more heating capacity. And use the start rapidly advantage of fixed frequency compressor to quickly up to output aim.

- Compressor soft start
- Lubrication system soft start

2.6 Convenient for installation and service

2.6.1 Auto addressing

The outdoor unit can automatically distribute the addresses to indoor units without any manual settings. Wireless controller and wired controller can query and modify each indoor unit's address.

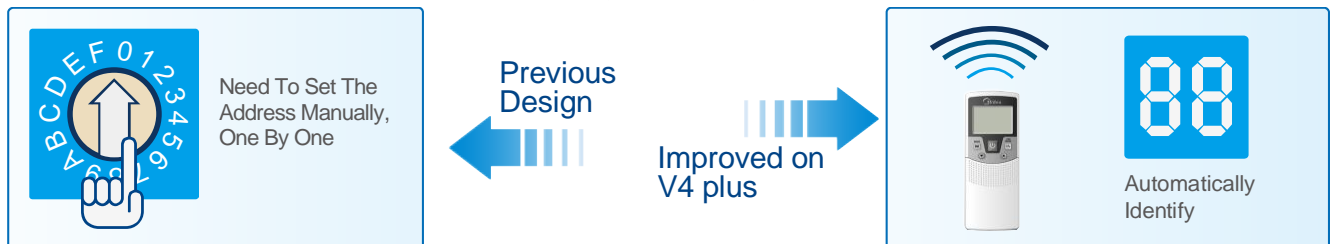

2.6.2 Super Wiring

It is possible to enable the shared use of the wiring between indoor & outdoor units, as well the centralized control. Hence make it easy for the user to retrofit the existing system with a centralized control, by simply connecting it to the outdoor units.

- PQE & XYE, just only one group of communication wire of PQE, achieved both of communication for indoor & outdoor unit and network.
- Reversible communication, central controller can connect from indoor side or outdoor side at will.

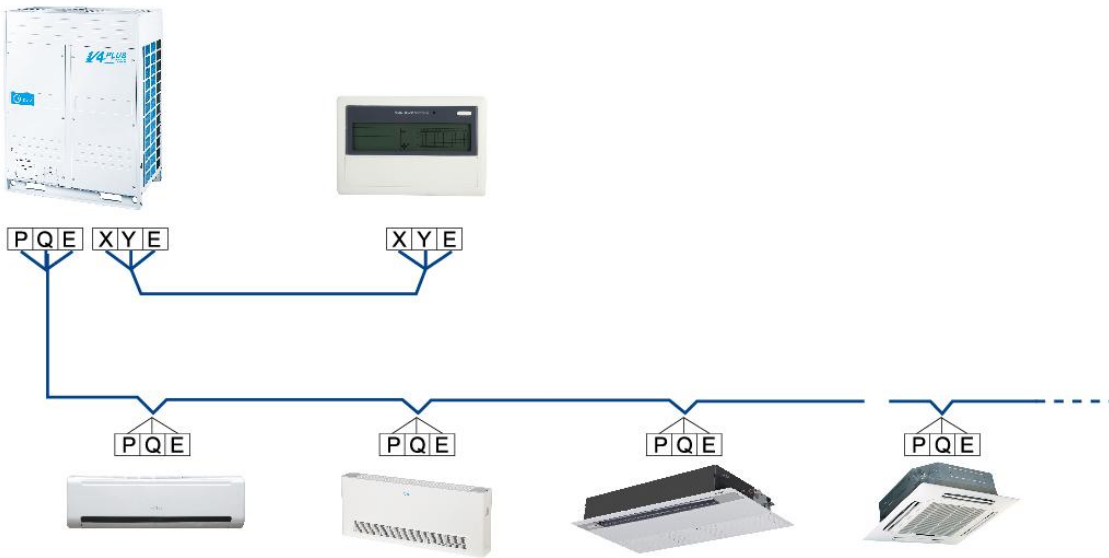

2.6.3 Convenient for maintenance



Convenient electronic control check window. Can directly observe the operation status from the LED display, and directly press the FORCE COOLING / CHECK button.

The high/low pressure valves adopt the Stop Valves, which has screwed thread nipple joint, can be connected the Meter connector directly for more convenience in air tight test. And also make more efficient and easy for installation.



Self diagnosis function and four-digit Digital display help service engineer to find out the fault fast and easily.

3. Model Lineup





Outdoor units (Combination Unit):







8, 10 HP	12, 14, 16 HP	18HP
		
20, 22, 24, 26, 28, 30, 32, 34, 36 HP		38, 40, 42, 44, 46, 48, 50, 52, 54 HP
		
56, 58, 60, 62, 64, 66, 68, 70, 72 HP		
		

4. Units Combination Table



Capacity (HP)	Model	Recommend combination						Max. indoor units nos.
		8(HP)	10(HP)	12(HP)	14(HP)	16(HP)	18(HP)	
8	MDV-252(8)W/DRN1(C)	●						13
10	MDV-280(10)W/DRN1(C)		●					16
12	MDV-335(12)W/DRN1(C)			●				20
14	MDV-400(14)W/DRN1(C)				●			23
16	MDV-450(16)W/DRN1(C)					●		26
18	MDV-500(18)W/DRN1(C)						●	29
20	MDV-560(20)W/DRN1(C)		●●					33
22	MDV-615(22)W/DRN1(C)		●	●				36
24	MDV-680(24)W/DRN1(C)		●		●			39
26	MDV-730(26)W/DRN1(C)		●			●		43
28	MDV-780(28)W/DRN1(C)		●				●	46
30	MDV-850(30)W/DRN1(C)				●	●		50
32	MDV-900(32)W/DRN1(C)				●		●	53
34	MDV-950(34)W/DRN1(C)					●	●	56
36	MDV-1000(36)W/DRN1(C)						●●	59
38	MDV-1060(38)W/DRN1(C)		●●				●	63
40	MDV-1130(40)W/DRN1(C)		●		●	●		64
42	MDV-1180(42)W/DRN1(C)		●			●●		64
44	MDV-1230(44)W/DRN1(C)		●			●	●	64
46	MDV-1280(46)W/DRN1(C)		●				●●	64
48	MDV-1350(48)W/DRN1(C)				●	●	●	64
50	MDV-1400(50)W/DRN1(C)				●		●●	64
52	MDV-1450(52)W/DRN1(C)					●	●●	64
54	MDV-1500(54)W/DRN1(C)						●●●	64
56	MDV-1560(56)W/DRN1(C)		●●				●●	64
58	MDV-1630(58)W/DRN1(C)		●		●	●	●	64
60	MDV-1680(60)W/DRN1(C)		●		●		●●	64
62	MDV-1730(62)W/DRN1(C)		●			●	●●	64
64	MDV-1780(64)W/DRN1(C)		●				●●●	64
66	MDV-1850(66)W/DRN1(C)				●	●	●●	64
68	MDV-1900(68)W/DRN1(C)				●		●●●	64
70	MDV-1950(70)W/DRN1(C)					●	●●●	64
72	MDV-2000(72)W/DRN1(C)						●●●●	64





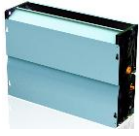
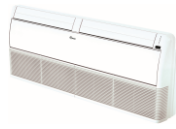

5. Indoor Units Lineup

Capacity (×100W)	Cassette type				
	One-way cassette		Two-way cassette	Compact four-way cassette	Four-way cassette
					
18	•				
22	•		•	•	
28	•		•	•	•
36	•		•	•	•
45		•	•	•	•
56		•	•		•
71		•	•		•
80					•
90					•
100					•
112					•
140					•

Capacity (×100W)	Duct type					
	Low static pressure duct	Medium static pressure duct	High static pressure duct			
						
18	•					
22	•	•				
28	•	•				
36	•	•				
45	•	•				
56	•	•				
71		•	•			
80		•	•			
90		•	•			
100						
112		•	•			
140		•		•		
160				•		
200					•	
250					•	
280					•	
400						•
450						•
560						•

Indoor units lineup

Capacity (×100W)	Floor-standing/Ceiling & Floor/Console			
	Cased floor-standing	Uncased floor-standing	Ceiling & floor	console
				
22	•	•	•	•
28	•	•		•
36	•	•	•	•
45	•	•	•	•
56	•	•	•	
71	•	•	•	
80	•	•	•	
90			•	
112			•	
140			•	
160			•	

Capacity (×100W)	Wall mounted/Fresh air processing unit					
	Wall mounted (S type panel)	Wall mounted (C type panel)	Wall mounted (R type panel)	Wall mounted (D series panel)	Fresh air processing unit	
						
22	•	•		•		
28	•	•		•		
36	•	•		•		
45	•	•		•		
56	•	•		•		
71			•	•		
80			•			
90			•			
125					•	
140					•	
200						•
250						•
280						•

Note: Due to continuous improvement, specifications are subject to change without prior notice.

6. Nomenclature

6.1 Outdoor unit:

MDV – 252 (8) W / D R N1 I (C)

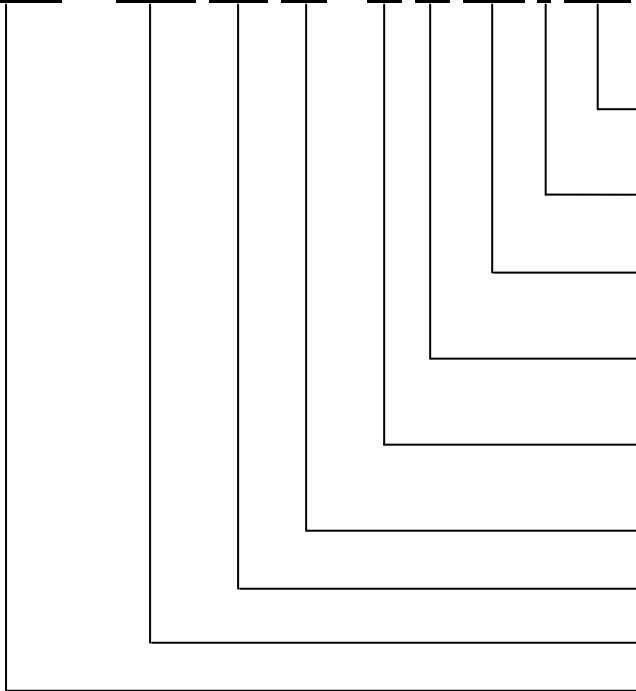

Design Serial Number

I: Individual Module

Omit: Combinable Module

Refrigerant type

N1:R410A Omit for R22

Power Supply

R: 380~415V, 50Hz, 3N

Inverter Type

D: DC Inverter Omit for AC Inverter

Outdoor Unit

Rated Capacity (HP), (only for combinable type)

Cooling Capacity (× 100W)

Midea

6.2 Indoor unit:

MDV – D 28 Z / D D N1 A

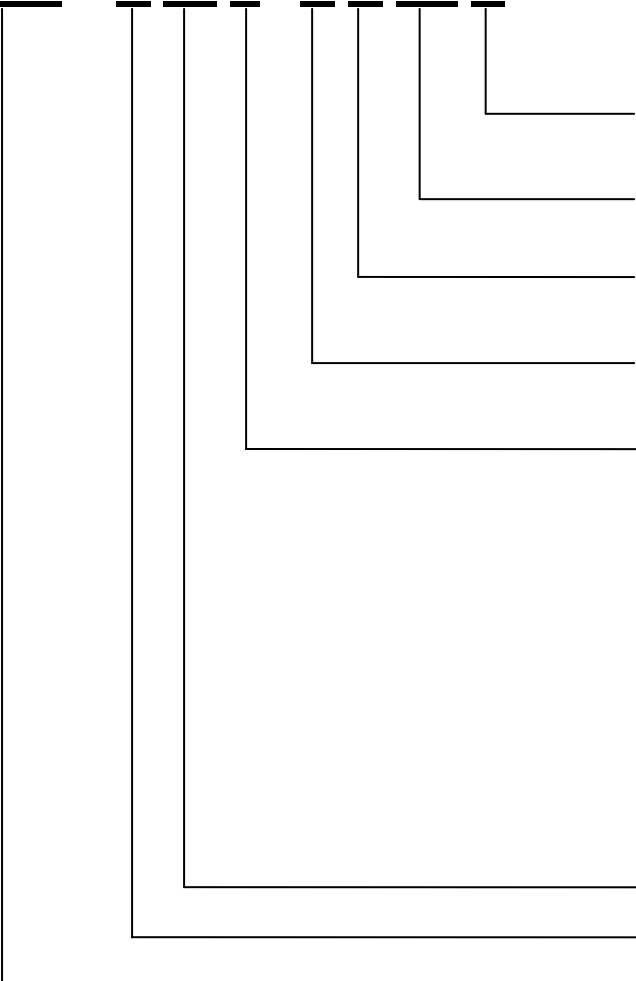

Design Serial Number& Improved code

Such as A1, A2, B1, B2, C, D, etc.

Refrigerant type

N1:R410A Omit for R22

Electrical Auxiliary Heater

D: with EAH Omit for without EAH

Motor Type

D: DC Fan Motor Omit for AC fan Motor

Indoor Unit Structural category

Q4: Standard four way cassette

Q4-A: Compact four way cassette

Q2: Two way cassette

T1: High Static Pressure Unit

T2: Middle Static Pressure Unit, such as T2-A3, T2-A5

T3: Low Static Pressure Unit,

DL: Ceiling & Floor Type

G: Wall mounted Type, such as G-S, G-C, etc.

Z: Floor Standing (Z-F4, Z-F5: Exposed /Z-F3: Concealed)

Cooling Capacity (× 100W)

VRF Indoor Unit

Midea

Part 2 Selection Procedure

- 1. Introduction..... 2
- 2. Unit selection (Based on cooling load)..... 6

Part 2 Selection
Procedure

1. Introduction

1.1 Model Selection Procedure

Select the model and calculate the capacity for each refrigerant system according to the procedure shown below.

- Calculation of the indoor air-conditioning load, Calculate the maximum air-conditioning load for each room or zone.

Selection of an air conditioning system

- Select the ideal air conditioning system for air conditioning of each room or zone

Design of the control system

- Design a suitable control system for the selected air conditioning system

Preliminary selection of indoor and outdoor units

- Make preliminary selections that are within the allowable range for the system

Check of the piping length and elevation difference

- Check that the length of refrigerant piping and the level difference are within the allowable ranges

Calculation of the corrected outdoor unit capacity

- Capacity correction coefficient for model, outdoor temperature conditions, piping length and level difference.

Calculation of the actual capacity for each indoor unit

- Calculate the corrected indoor/outdoor capacity ratio, based on the corrected outdoor unit capacity and the total corrected capacity of all indoor units in the same system.

Recheck of the actual capacity for each indoor unit

- If the capacity is inadequate, reexamine the unit combinations.

1.2 Indoor Unit Selection

Enter INDOOR UNIT CAPACITY TABLES at given indoor and outdoor temperature. Select the unit that the capacity is the nearest to and greater than given load.

Note:

Individual indoor unit capacity is subject to change by the combination. Actual capacity has to be calculated according to the combination by using outdoor unit capacity table.

1.2.1 Calculation of Actual Capacity of Indoor Unit

Because the capacity of a multi air-conditioner changes according to the temperature conditions, piping length, level difference and other factors, select the correct model after taking the various correction values into account. When selecting the model, calculate the corrected capacities of the outdoor unit and each indoor unit. Use the corrected outdoor unit capacity and the total corrected capacity of all the indoor units to calculate the actual final capacity of each indoor unit.

Find the indoor unit capacity correction coefficient for the following items

- Capacity correction for the indoor unit temperature conditions
From the graph of capacity characteristics, use the indoor temperature to find the capacity correction coefficient.
- Capacity distribution ratio based on the indoor unit piping length and level difference.
First, in the same way as for the outdoor unit, use the piping length and level difference for each indoor unit to find the correction coefficient from the graph of capacity change characteristics

Capacity distribution ratio for each indoor unit = Correction coefficient for that indoor unit / Correction coefficient for the outdoor unit

1.3 Outdoor Unit Selection

Allowable combinations are indicated in INDOOR UNIT COMBINATION TOTAL CAPACITY INDEX TABLE.

In general, outdoor unit can be selected as follows though the location of the unit, zoning and usage of the rooms may be considered.

The indoor and outdoor unit combination is determined by that the sum of indoor unit capacity index is

nearest to and smaller than the capacity index at 100% combination ratio of each outdoor unit. Up to 8~16 indoor units can be connected to one outdoor unit. It is recommended to choose a larger capacity outdoor unit if the installation space is large enough.

If the combination ratio is greater than 100%, the indoor unit selection shall be reviewed by using actual capacity of each indoor unit.

INDOOR UNIT COMBINATION TOTAL CAPACITY INDEX TABLE

Outdoor Unit	Indoor Unit Combination Ratio (kW)								
	130%	120%	110%	100%	90%	80%	70%	60%	50%
8HP	32.8	30.2	27.7	25.2	22.7	20.2	17.6	15.1	12.6
10HP	36.4	33.6	30.8	28.0	25.2	22.4	19.6	16.8	14.0
12HP	43.6	40.2	36.9	33.5	30.2	26.8	23.5	20.1	16.8
14HP	52.0	48.0	44.0	40.0	36.0	32.0	28.0	24.0	20.0
16HP	58.5	54.0	49.5	45.0	40.5	36.0	31.5	27.0	22.5
18HP	65.0	60.0	55.0	50.0	45.0	40.0	35.0	30.0	25.0
20HP	72.8	67.2	61.6	56.0	50.4	44.8	39.2	33.6	28.0
22HP	80.0	73.8	67.7	61.5	55.4	49.2	43.1	36.9	30.8
24HP	88.4	81.6	74.8	68.0	61.2	54.4	47.6	40.8	34.0
26HP	94.9	87.6	80.3	73.0	65.7	58.4	51.1	43.8	36.5
28HP	101.4	93.6	85.8	78.0	70.2	62.4	54.6	46.8	39.0
30HP	110.5	102.0	93.5	85.0	76.5	68.0	59.5	51.0	42.5
32HP	117.0	108.0	99.0	90.0	81.0	72.0	63.0	54.0	45.0
34HP	123.5	114.0	104.5	95.0	85.5	76.0	66.5	57.0	47.5
36HP	130.0	120.0	110.0	100.0	90.0	80.0	70.0	60.0	50.0
38HP	137.8	127.2	116.6	106.0	95.4	84.8	74.2	63.6	53.0
40HP	146.9	135.6	124.3	113.0	101.7	90.4	79.1	67.8	56.5
42HP	156.0	141.6	129.8	118.0	106.2	94.4	82.6	70.8	59.0
44HP	159.9	147.6	135.3	123.0	110.7	98.4	86.1	73.8	61.5
46HP	166.4	153.6	140.8	128.0	115.2	102.4	89.6	76.8	64.0
48HP	175.5	162.0	148.5	135.0	121.5	108.0	94.5	81.0	67.5
50HP	182.0	168.0	154.0	140.0	126.0	112.0	98.0	84.0	70.0
52HP	188.5	174.0	159.5	145.0	130.5	116.0	101.5	87.0	72.5
54HP	195.0	180.0	165.0	150.0	135.0	120.0	105.0	90.0	75.0
56HP	202.8	187.2	171.6	156.0	140.4	124.8	109.2	93.6	78.0
58HP	211.9	195.6	179.3	163.0	146.7	130.4	114.1	97.8	81.5
60HP	218.4	201.6	184.8	168.0	151.2	134.4	117.6	100.8	84.0
62HP	224.9	207.6	190.3	173.0	155.7	138.4	121.1	103.8	86.5
64HP	231.4	213.6	195.8	178.0	160.2	142.4	124.6	106.8	89.0
66HP	240.5	222.0	203.5	185.0	166.5	148.0	129.5	111.0	92.5
68HP	247.0	228.0	209.0	190.0	171.0	152.0	133.0	114.0	95.0
70HP	253.5	234.0	214.5	195.0	175.5	156.0	136.5	117.0	97.5
72HP	260.0	240.0	220.0	200.0	180.0	160.0	140.0	120.0	100.0

INDOOR UNIT CAPACITY INDEX

Unit Size	Model 18	Model 22	Model 28	Model 36	Model 45	Model 56	Model 71	Model 80	Model 90	Model 100
Capacity Index (kW)	1.8	2.2	2.8	3.6	4.5	5.6	7.1	8.0	9.0	10.0
Unit Size	Model 112	Model 125	Model 140	Model 160	Model 200	Model 250	Model 280	Model 400	Model 450	Model 560
Capacity Index (kW)	11.2	12.5	14.0	16.0	20.0	25.0	28.0	40.0	45.0	56.0

1.4 Actual Performance Data

Use OUTDOOR UNIT CAPACITY TABLES.

Find the corresponding correct table according to the outdoor unit model and combination ratio.

Enter the table at given indoor and outdoor temperature and find the outdoor unit capacity and power input. The individual indoor unit capacity (power input) can be calculated as follows.

$$IUC = OUC \times INX / TNX$$

Where,

IUC: Each indoor unit capacity

OUC: Outdoors unit capacity

INX: Each indoor unit capacity index

TNX: Total capacity index

Then, correct the indoor unit capacity according to the piping length.

If the corrected capacity is smaller than the load, the capacity of indoor unit has to be increased and repeat the same selection procedure.

1.5 Variation in capacity in accordance with the length of refrigerant pipe

1.5.1 Cooling capacity modification

Modification coefficient of the length and level difference of refrigerant pipe:

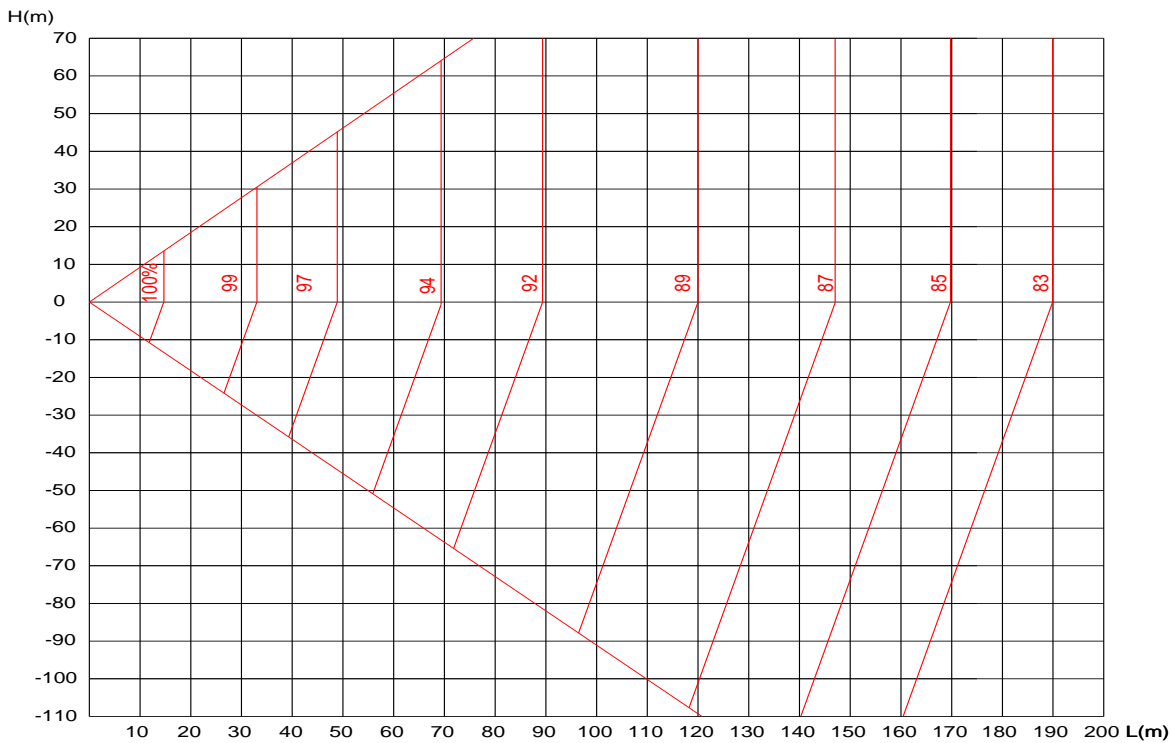

L: Refrigerant pipe equivalent length

H: Level difference between outdoor and indoor unit. Positive data means outdoor unit is top. Negative data means outdoor unit is down.

1.5.2 Heating capacity modification

Modification coefficient of the length and level difference of refrigerant pipe:

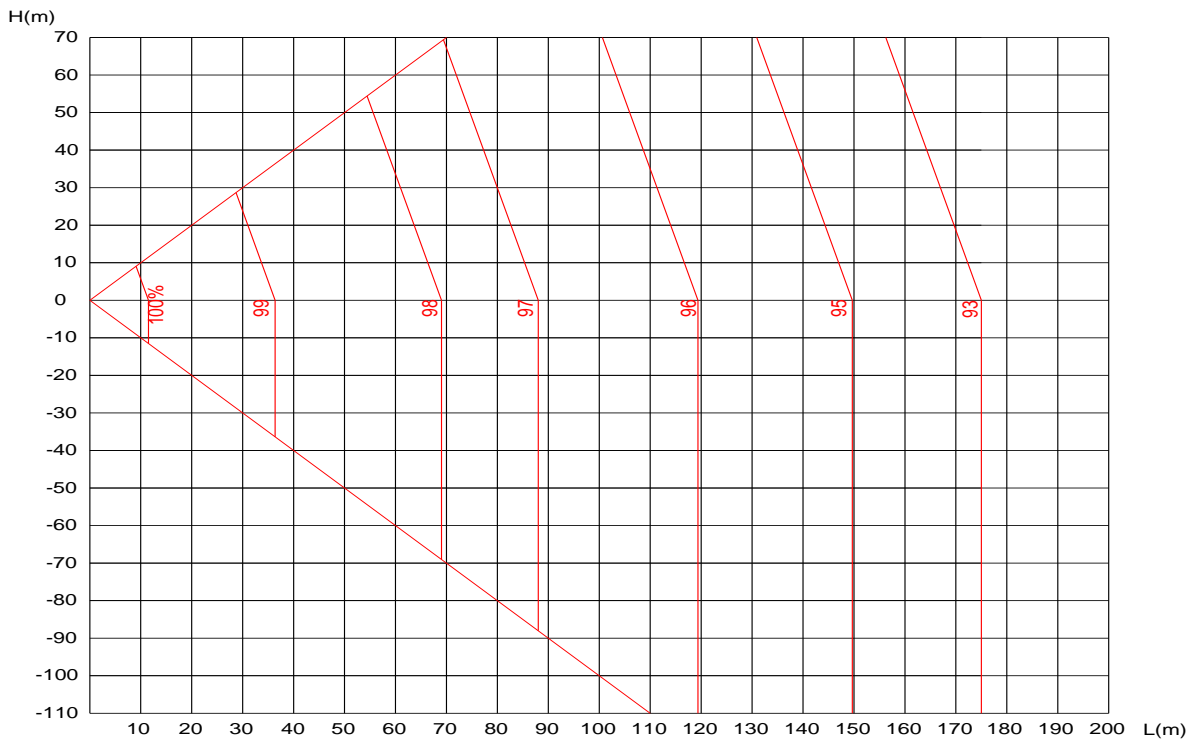

L: Refrigerant pipe equivalent length

H: Level difference between outdoor and indoor unit. Positive data means outdoor unit is up. Negative data means outdoor unit is down.

2. Unit Selection (Based on cooling load)

2.1 Given condition

2.1.1 Design condition (Cooling: Indoor 20°C (WB), Outdoor 35°C (DB))

2.1.2 Cooling load

Location	Room A	Room B	Room C	Room D	Room E	Room F
Load (kW)	2.1	2.8	3.5	4.6	5.8	7.2

2.1.3 Power supply unit: Outdoor 380~415V-3Ph-50Hz, Indoor 220~240V-1Ph-50Hz.

2.1.4 Piping length: 50m

2.1.5 Level difference: 30m

2.2 Indoor unit selection

Select the suitable capacity for condition of 'Indoor 20°C (WB), Outdoor 35°C (DB)' using indoor unit capacity table. The selected result is as follows. (Assuming the indoor unit type is duct)

Location	Room A	Room B	Room C	Room D	Room E	Room F
Load (kW)	2.1	2.8	3.5	4.6	5.8	7.2
Unit size	22	28	36	45	56	71
Capacity (kW)	2.3	2.9	3.7	4.8	6.0	7.5

2.3 Outdoor unit selection

2.3.1 Assume the indoor unit and outdoor unit combination as follows

2.3.1.1 Calculate the total nominal capacity of indoor units in the combination according to the above table:

$$2.2 \times 1 + 2.8 \times 1 + 3.6 \times 1 + 4.5 \times 1 + 5.6 \times 1 + 7.1 \times 1 = 25.8\text{kW}$$

2.3.1.2 Select outdoor unit: MDV-280(10)W/DRN1(D) which has nominal cooling capacity: 28kW.

Calculate the proportion between ① and ②: $25.8/28 = 92\%$

2.3.2 Result : Because the proportion is within 50~130%, it is a "Right" selection.

2.3.3 Real function data with indoor unit combination

- For the 92% combination, calculate the cooling capacity of outdoor unit (MDV-280(10)W/DRN1(D)).

26.65KW ←90% (Indoor temperature : **WB 20°C**, Outdoor temperature: **DB 35°C**)

29.61KW ←100%(Indoor temperature : **WB 20°C**, Outdoor temperature: **DB 35°C**)

Then calculated the outdoor capacity in 92% combination index:

Therefore: $26.65 + \{(29.61 - 26.65) / 10\} \times 2 = 27.24$;

- Outdoor unit (MDV-280(10)W/DRN1(D)) cooling temperature: DB 35°C
- Capacity modification coefficient with pipe length (50m) and level difference (30m): 0.958
- Each indoor unit cooling capacity

MDV-D22T2: $27.24 \times 22/258 \times 0.958 = 2.22(\text{kW})$

MDV-D28T2: $27.24 \times 28/258 \times 0.958 = 2.83(\text{kW})$

MDV-D36T2: $27.24 \times 36/258 \times 0.958 = 3.64(\text{kW})$

MDV-D45T2: $27.24 \times 45/258 \times 0.958 = 4.55(\text{kW})$

MDV-D56T2: $27.24 \times 56/258 \times 0.958 = 5.66(\text{kW})$

MDV-D71T2: $27.24 \times 71/258 \times 0.958 = 7.18(\text{kW})$

Location	Room A	Room B	Room C	Room D	Room E	Room F
Load (kW)	2.1	2.8	3.5	4.6	5.8	7.2
Unit size	22	28	36	45	56	71
Capacity (kW)	2.22	2.83	3.64	4.55	5.66	7.18

2.4 Conclusion

Generally, we think this result is acceptable, so we we have accomplished the calculation. But if you think this result is not acceptable, you can repeat the above process.

Remark: In this sample, we don't consider other capacity modification indexes and assume them are 1.0.

For more details about the effect factor such as outside ambient/inside ambient DB/WD , please refer to the performance table of indoor and outdoor units.

Part 3 Specification & Performance

- 1. Specifications.....2**
- 2. Dimensions.....6**
- 3. Piping Diagrams..... 11**
- 4. Electric Characteristics 13**
- 5. Wiring Diagrams and Field Wiring..... 13**
- 6. Operation Limits 17**
- 7. Capacity Tables 17**
- 8. Sound Levels.....60**
- 9. Accessories.....61**

Part 3 Specification & Performance

1. Specifications

Model		MDV-252(8)W/DRN1(C)	MDV-280(10)W/DRN1(C)	MDV-335(12)W/DRN1(C)
Power supply		V-Ph-Hz	380~415V 3Ph ~ 50Hz	380~415V 3Ph ~ 50Hz
Cooling (*1)	Capacity	W	25200	28000
	Input	W	5875	7198
	EER	W/W	4.29	3.89
Heating (*2)	Capacity	W	27000	31500
	Input	W	6150	7609
	COP	W/W	4.39	4.14
Max. input consumption		W	11270	12864
Max. current		A	20.8	23.7
DC inverter compressor	Model		E655DHD-65D2YG	E655DHD-65D2YG
	Quantities		1	1
	Type		DC inverter	DC inverter
	Brand		Hitachi	Hitachi
	Capacity	W	31590	31590
	Input	W	10340	10340
	Power supply	V-Ph-Hz	380-415V~3Ph, 50Hz	380-415V~3Ph, 50Hz
	Operating frequency	Hz	40~200	40~200
	Crankcase	W	27.6+27.6	27.6+27.6
	Refrigerant oil	ml	FVC68D / 500	FVC68D / 500
Fixed scroll compressor	Model			E655DH-65D2YG(GC)
	Quantities			1
	Type			Fixed scroll
	Brand			Hitachi
	Capacity	W		17100
	Input	W		5740
	Power supply	V-Ph-Hz		380-415V~3Ph, 50Hz
	Locked rotor ampere (LRA)	A		68
	Thermal protector type			Inner
	Crankcase	W		27.6
Refrigerant oil	ml		FVC68D / 500	
Outdoor fan motor	Model		WZDK750-38G-4	WZDK750-38G-4
	Brand		Panasonic/Nidec	Panasonic/Nidec
	Quantities		1	1
	Insulation class		E	E
	Safe class		IPX4	IPX4
	Input	W	465	465
	Output	W	750	750
	Rated current	A	3.6	3.6
	Speed	r/min	800	800
Outdoor fan	Material		Plastic	Plastic
	Type		Axial	Axial
	Fan Quantities		1	1
	Dimension(Diameter × H)	mm	700×202	700×202
	Vane Quantities of each blower		3	3
Outdoor coil	Number of rows		2	2
	Tube pitch(a) × row pitch(b)	mm	22×19.05	22×19.05
	Fin spacing	mm	1.6	1.6
	Fin type		Hydrophilic aluminum	Hydrophilic aluminum
	Tube outside diameter	mm	Φ7.94	Φ7.94

	Tube type		Inner-grooved	Inner-grooved	Inner-grooved
	Coil length x height	mm	1985x1232	1985x1232	2270x1232
	Number of circuits		22	22	22
Outdoor air flow		m ³ /h	11500	11500	15100
External static pressure		Pa	0~20 (default)	0~20 (default)	0~20 (default)
			20~40 (optional)	20~40 (optional)	20~60 (optional)
Outdoor sound pressure level(*3)		dB(A)	57	57	59
Outdoor unit	Dimension(WxHxD)	mm	960x1615x765	960x1615x765	1250x1615x765
	Packing (WxHxD)	mm	1025x1790x830	1025x1790x830	1305x1790x825
	Net/Gross weight	kg	198/213	198/213	268/288
Charged refrigerant type and volume		kg	R410A 9kg	R410A 9kg	R410A 11kg
Throttle type			EXV	EXV	EXV
Excessive operating pressure		MPa	4.4/2.6	4.4/2.6	4.4/2.6
Refrigerant piping	Liquid side/ Gas side	mm	Φ12.7/Φ25.4	Φ12.7/Φ25.4	Φ15.9/Φ31.8
	Oil balance pipe	mm	Φ6.35	Φ6.35	Φ6.35
	Total pipe length	m	1000	1000	1000
	The farthest pipe length(actual)	m	175	175	175
	The farthest pipe length (equivalent)	m	200	200	200
	The farthest equivalent pipe length from the 1st distributor (*4)	m	40/90	40/90	40/90
	Max. vertical pipe length (When outdoor units is top)	m	70	70	70
	Max. vertical pipe length (When outdoor units is bottom)	m	110	110	110
	Max. drop between indoor units	m	30	30	30
Connection wiring	Power wiring	mm ²	4×10+10(L≤20m);	4×10+10(L≤20m);	4×10+10(L≤20m);
			4×16+10(L≤50m)	4×16+10(L≤50m)	4×16+10(L≤50m)
Signal wiring	mm ²	3 core shielded wiring;	3 core shielded wiring;	3 core shielded wiring;	
		Wiring diameter ≥0.75	Wiring diameter ≥0.75	Wiring diameter ≥0.75	
Ambient temperature range - Cooling		℃	-5℃—48℃	-5℃—48℃	-5℃—48℃
Ambient temperature range - Heating		℃	-20℃—27℃	-20℃—27℃	-20℃—27℃

Notes:

1. The cooling conditions: indoor temperature: 27℃DB(80.6°F), 19℃WB(60°F), outdoor temperature: 35℃DB(95°F), equivalent pipe length: 5m, level difference: 0m.
2. The heating conditions: indoor temperature: 20℃DB(68°F), 15℃WB(44.6°F), outdoor temperature: 7℃DB(42.8°F), equivalent pipe length: 5m, level difference: 0m.
3. Sound pressure level: Anechoic chamber conversion value, measured at a point 1 m in front of the unit at a height of 1.5 m. During actual operation, these values are normally somewhat higher as result of ambient conditions.
4. The farthest equivalent pipe length should be equal to or shorter than 40m, but it can be up to 90m if meet the required conditions following part 4 installation section
5. The above data may be changed without notice for future improvement on quality and performance.

Model		MDV-400(14)W/DRN1(C)	MDV-450(16)W/DRN1(C)	MDV-500(18)W/DRN1(C)
Power supply		V-Ph-Hz	380~415V 3Ph ~ 50Hz	380~415V 3Ph ~ 50Hz
Cooling (*1)	Capacity	W	40000	45000
	Input	W	12308	14019
	EER	W/W	3.25	3.21
Heating (*2)	Capacity	W	45000	50000
	Input	W	11194	12787
	COP	W/W	4.02	3.91
Max. input consumption		W	16530	20390
Max. current		A	31.8	35.4
DC Inverter compressor	Model		E655DHD-65D2YG	E655DHD-65D2YG
	Quantities		1	1
	Type		DC Inverter	DC Inverter
	Brand		Hitachi	Hitachi
	Capacity	W	31590	31590
	Input	W	10340	10340
	Power supply	V-Ph-Hz	380-415V~3Ph, 50Hz	380-415V~3Ph, 50Hz
	Operating frequency	Hz	40~200	40~200
	Crankcase	W	27.6+27.6	27.6+27.6
	Refrigerant oil	ml	FVC68D / 500	FVC68D / 500
Fixed scroll compressor	Model		E605DH-59D2YG	E655DH-65D2YG(GC)
	Quantities		1	1
	Type		Fixed scroll	Fixed scroll
	Brand		Hitachi	Hitachi
	Capacity	W	15390	17100
	Input	W	5130	5740
	Power supply	V-Ph-Hz	380-415V~3Ph, 50Hz	380-415V~3Ph, 50Hz
	Locked rotor ampere (LRA)	A	62	68
	Thermal protector type		Inner	Inner
	Crankcase	W	27.6	27.6
Refrigerant oil	ml	FVC68D / 500	FVC68D / 500	
Outdoor fan motor	Model		WZDK560-38G(A)/YDK380-4D	WZDK560-38G(A)/YDK380-4D
	Brand		Broad-ocean/Panasonic, YongAn	Broad-ocean/Panasonic, YongAn
	Quantities		1+1	1+1
	Insulation class		E	E
	Safe class		IPX4	IPX4
	Input	W	465+640	465+640
	Output	W	560+380	560+380
	Rated current	A	3.6+2.94	3.6+2.94
	Speed	r/min	800+1060	800+1060
Outdoor fan	Material		Plastic	Plastic
	Type		Axial	Axial
	Fan Quantities		2	2
	Dimension(Diameter xH)	mm	560x189	560x189
	Vane Quantities of each blower		3/4	3/4
Outdoor coil	Number of rows		2	2
	Tube pitch(a) × row pitch(b)	mm	22x19	22x19
	Fin spacing	mm	1.6	1.6
	Fin type		Hydrophilic aluminum	Hydrophilic aluminum
	Tube outside diameter	mm	Φ7.94	Φ7.94

	Tube type		Inner-grooved	Inner-grooved	Inner-grooved
	Coil length x height	mm	2270x1232	2270x1232	2837x1232
	Number of circuits		22	22	22
Outdoor air flow		m ³ /h	15100	15100	15250
External static pressure		Pa	0~20 (default)	0~20 (default)	0~20 (default)
			20~40 (optional)	20~40 (optional)	20~40 (optional)
Outdoor sound pressure level (*3)		dB(A)	60	60	61
Outdoor unit	Dimension(WxHxD)	mm	1250x1615x765	1250x1615x765	1250x1615x765
	Packing (WxHxD)	mm	1305x1790x825	1305x1790x825	1305x1790x825
	Net/Gross weight	kg	280/300	280/300	300/320
Charged refrigerant type and volume		kg	R410A 13kg	R410A 13kg	R410A 16kg
Throttle type			EXV	EXV	EXV
Excessive operating pressure		MPa	4.4/2.6	4.4/2.6	4.4/2.6
Refrigerant piping	Liquid side/ Gas side	mm	Φ15.9/Φ31.8	Φ15.9/Φ31.8	Φ19.1/Φ31.8
	Oil balance pipe	mm	Φ6.35	Φ6.35	Φ6.35
	Total pipe length	m	1000	1000	1000
	The farthest pipe length(actual)	m	175	175	175
	The farthest pipe length (equivalent)	m	200	200	200
	The farthest equivalent pipe length from the 1st distributor (*4)	m	40/90	40/90	40/90
	Max. vertical pipe length (When outdoor units is top)	m	70	70	70
	Max. vertical pipe length (When outdoor units is bottom)	m	110	110	110
	Max. drop between indoor units	m	30	30	30
Connection wiring	Power wiring	mm ²	4×16+16(L≤20m);	4×16+16(L≤20m);	4×16+16(L≤20m);
			4×25+16(L≤50m)	4×25+16(L≤50m)	4×25+16(L≤50m)
Signal wiring	mm ²	3 core shielded wiring;	3 core shielded wiring;	3 core shielded wiring;	
		Wiring diameter ≥0.75	Wiring diameter ≥0.75	Wiring diameter ≥0.75	
Ambient temperature range - Cooling		℃	-5℃—48℃	-5℃—48℃	-5℃—48℃
Ambient temperature range - Heating		℃	-20℃—27℃	-20℃—27℃	-20℃—27℃

Notes:

1. The cooling conditions: indoor temperature: 27℃DB(80.6°F), 19℃WB(60°F), outdoor temperature: 35℃DB(95°F), equivalent pipe length: 5m, level difference: 0m.
2. The heating conditions: indoor temperature: 20℃DB(68°F), 15℃WB(44.6°F), outdoor temperature: 7℃DB(42.8°F), equivalent pipe length: 5m, level difference: 0m.
3. Sound pressure level: Anechoic chamber conversion value, measured at a point 1 m in front of the unit at a height of 1.5 m. During actual operation, these values are normally somewhat higher as result of ambient conditions.
4. The farthest equivalent pipe length should be equal to or shorter than 40m, but it can be up to 90m if meet the required conditions following part 4 installation section
5. The above data may be changed without notice for future improvement on quality and performance.

2. Dimensions

2.1 Units Dimension

8HP/10HP Dimensions (Combinable):

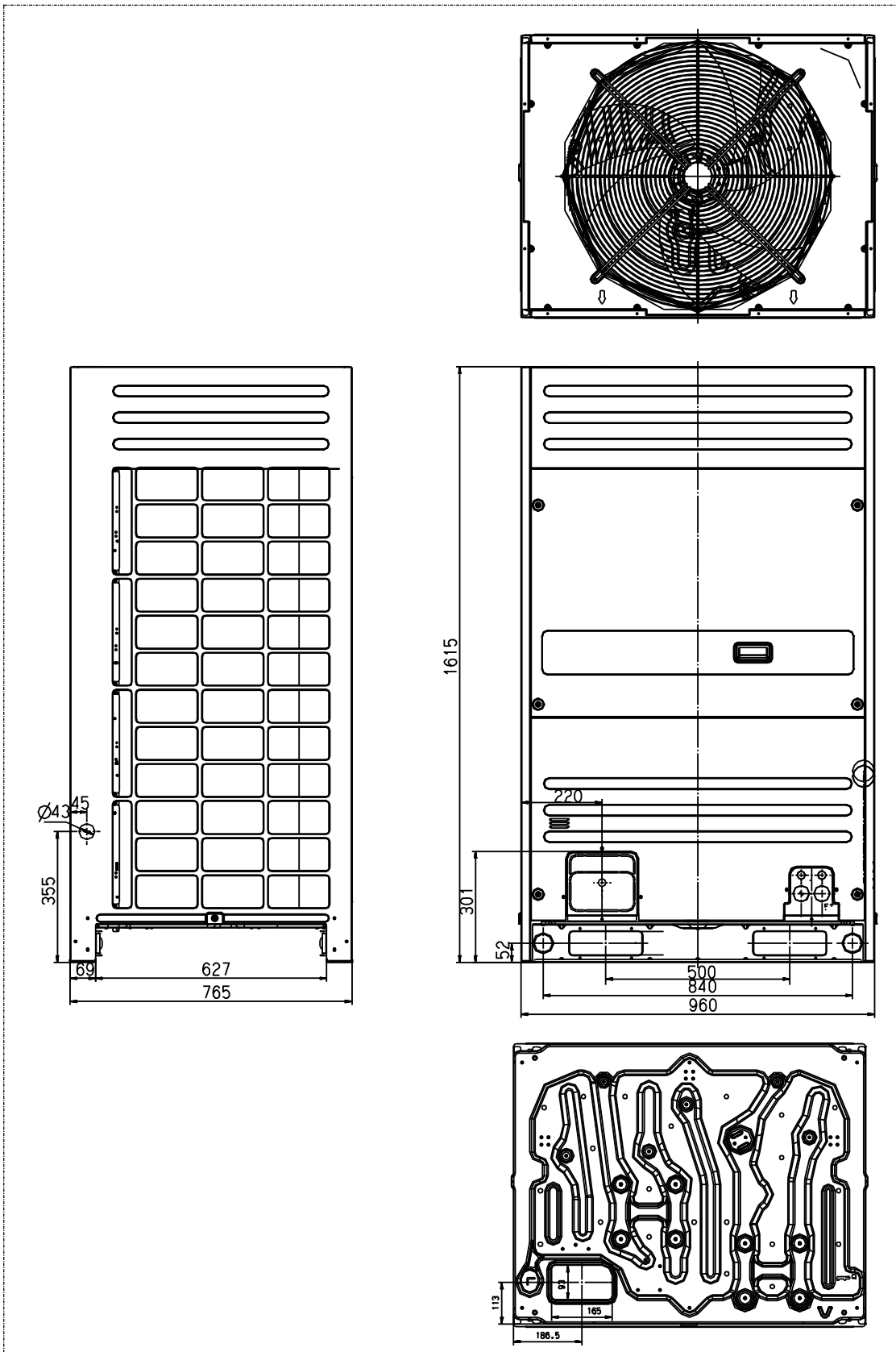

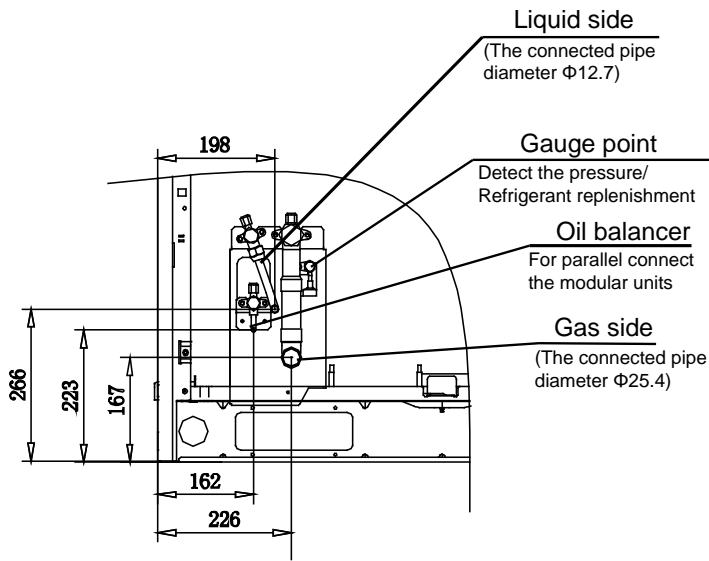
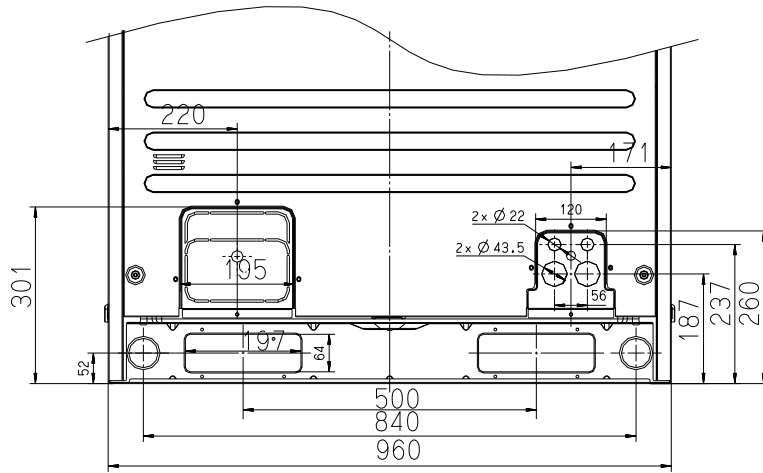

Enlarged view for 8HP/10HP

12HP/14HP/16HP/18HP (Combinable) Dimensions:

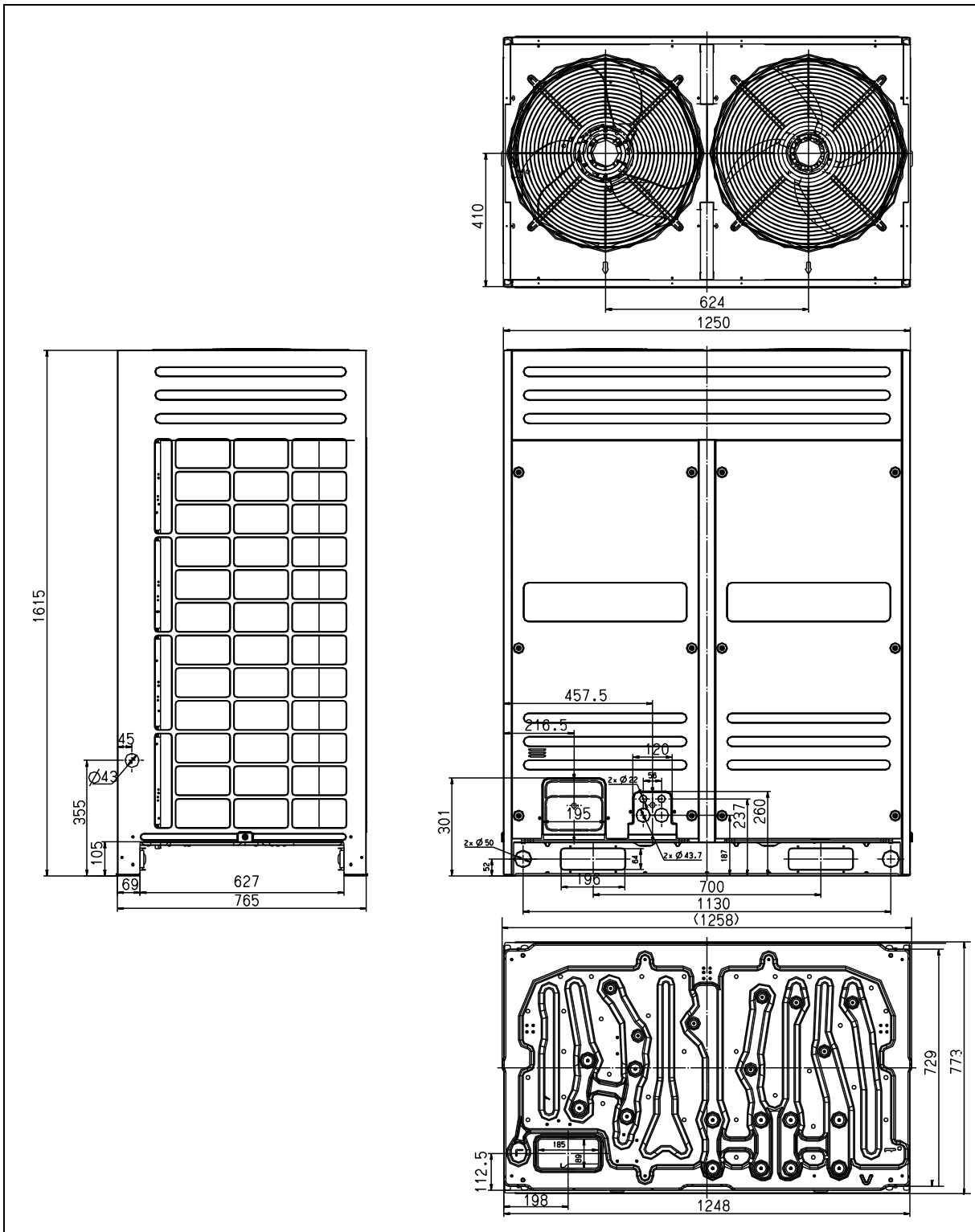

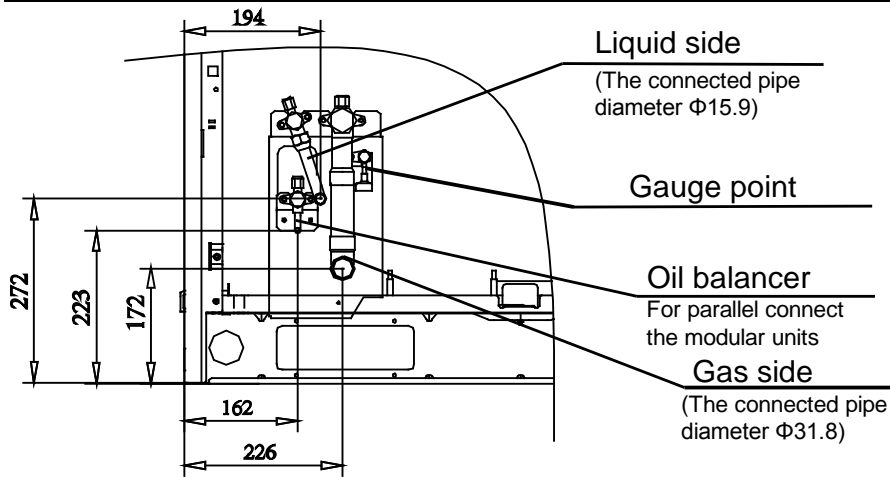
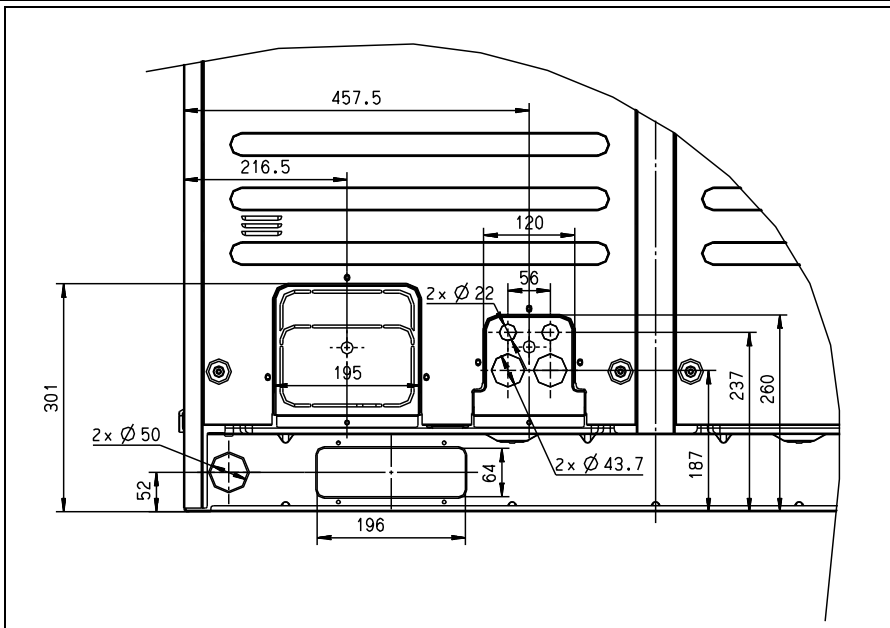

Enlarged view for 12HP/14/16HP

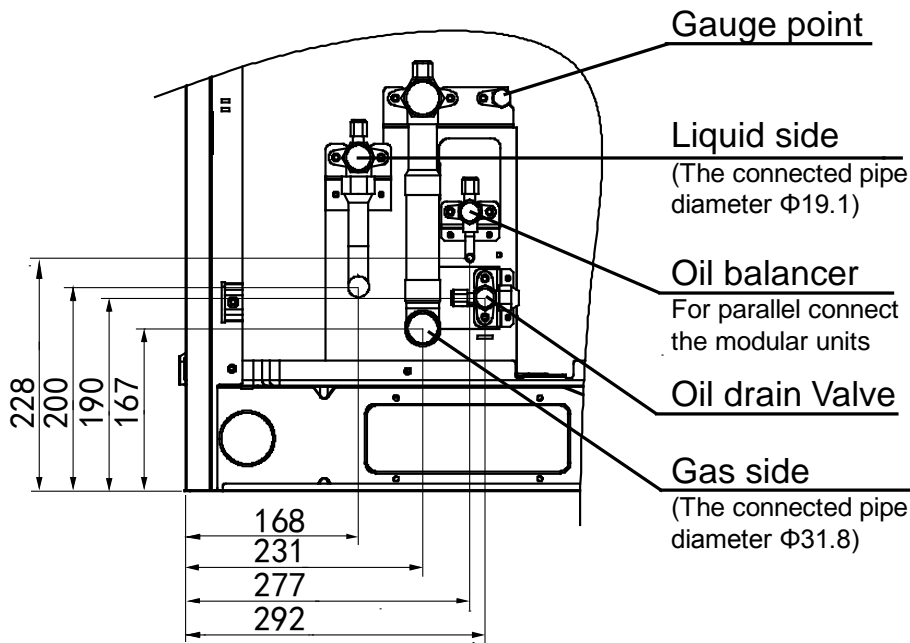

Enlarged view for 18HP

2.2 Position of Foot screw bolt (Unit: mm)

	8,10HP	12,14,16,18HP
A	830	1120
B	960	1250
C	736	736
D	765	765

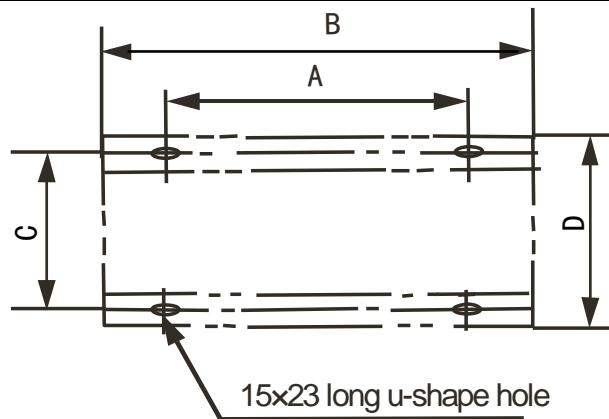

2.3 Valve explanation

8~16HP

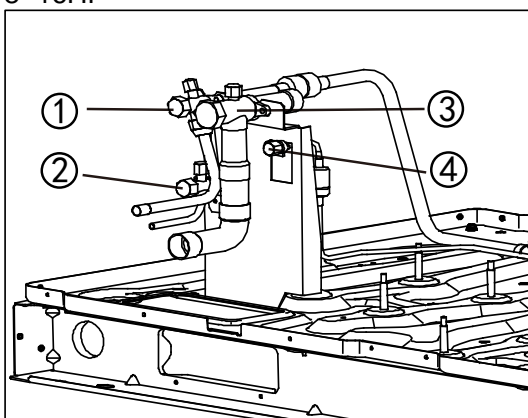

- ①Liquid pipe stop valve
- ②Oil balancer
- ③Gas pipe stop valve
- ④Gauge point (Use for detecting pressure and refrigerant)

18HP

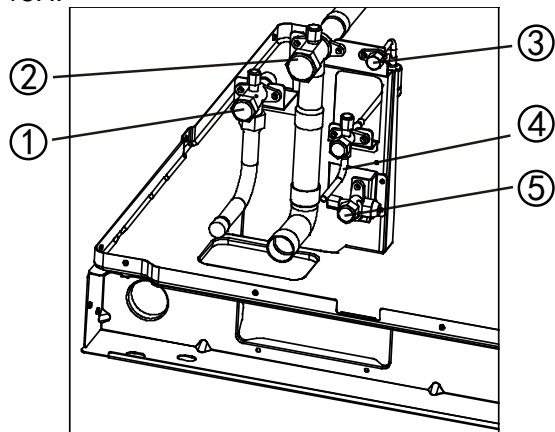

- ①Liquid pipe stop valve
- ②Gas pipe stop valve
- ③Gauge point (Use for detecting pressure and refrigerant)
- ④Oil balancer
- ⑤Oil drain valve

Note: For a single modular that is not necessary to connect with oil balance

3. Piping Diagrams

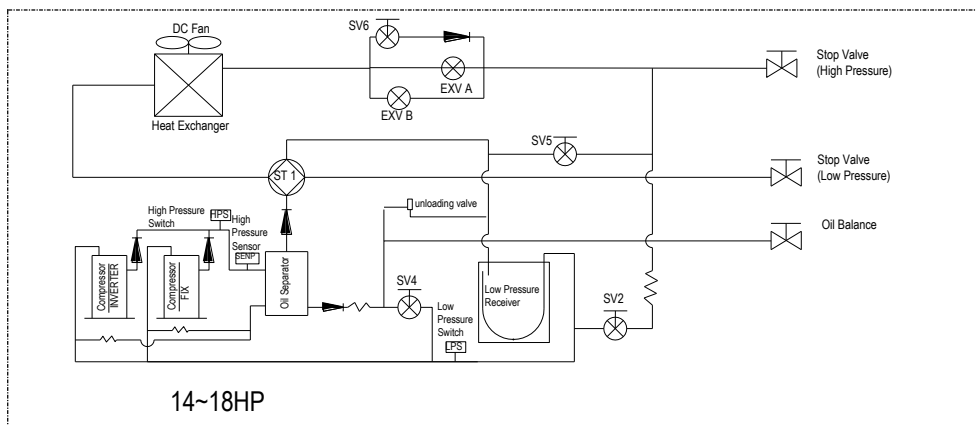
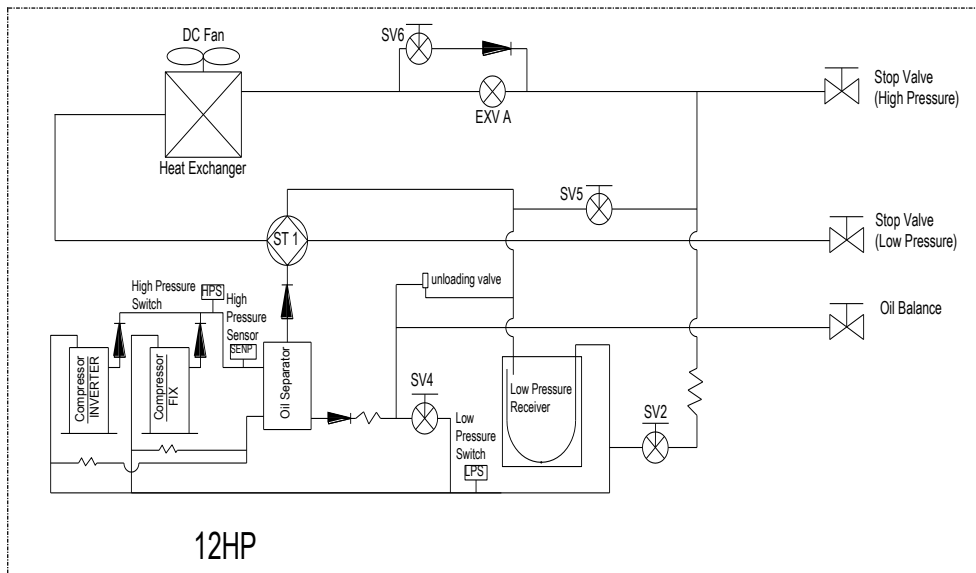
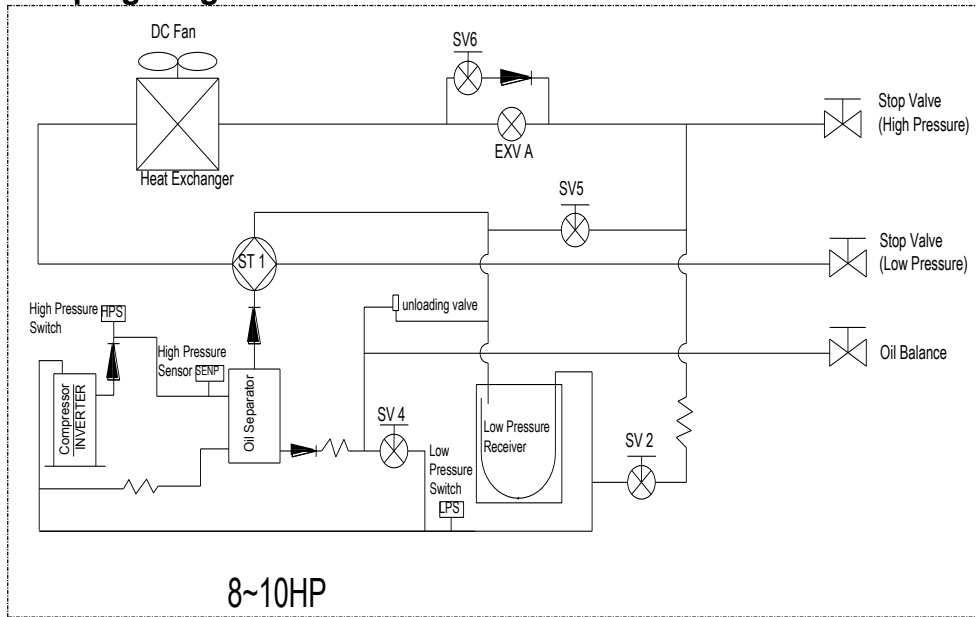

Remark:

1. 8~10 HP models only have one inverter compressor.
2. 12~18HP each has one big capacity inverter compressor and a small fix scroll compressor.
3. 14~18HP models have two EXV part at the high-pressure pipe side, different with 12HP model.

Key Components:

Oil Separator: Used to separate oil from high pressure & temperature gas refrigerant, which is pumped out from compressor. The separation efficiency is up to 99% and it makes the oil return back to each compressor very soon.

Low pressure receiver: It is used to store the liquid refrigerant and oil and protect the compressor from liquid hammer.

Four-way valve control (ST1): Closes in cooling mode and opens in heating mode

EXV (electromagnetic expansion valve) control:

- 1) Max. open degree is 480 pulses.
- 2) Generally, when system is plug in the EXV closes 700 pulse first, then opens to 350 pulse and stand by. When the unit started, it opens to the right pulse.
- 3) When the running outdoor unit receives OFF signal, the EXV of slave units will close while master unit is running continue and slave units will stop at the same time. If all outdoor units are stopped, the EXV of master unit will close first, and then open to the pulse of standby.
- 4) 8HP~12HP models have one EXV; 14~18HP models have double EXVs

SV2: spray a little liquid refrigerant to cooling compressor. Open when any compressor discharge temperature is higher than 100°C.

SV4: oil returning valve. Opens after the DC inverter compressor has been run for 5 minutes and then closes 15 minutes later. (For the system has only one outdoor unit).

Every 20 minutes, SV4 of each outdoor unit opens for 3 minutes. (For the system has more than one outdoor unit)

SV5: for defrosting. In defrosting mode, the opening of SV5 can cut the refrigerant flowing circle and the defrosting process will takes less time .In cooling mode, it is always off.

SV6: for by-pass. Closed when the unit stands by and system is running at heating mode. Open when the discharge temperature is over-high in cooling mode, and close when the unit is standby or system is in heating mode.

Hi pressure sensor: To supervisor the discharge pressure of the compressor and to control the DC fan speed.

For example.

Cooling mode launch sequence (The unit has accomplish commissioning):

Plug in and unit start-----SV4,SV5 open^{60s later} SV5 closed^{60s later} SV4 closed ^{40s later}
 Inverter compressor start at 40hz^{50slater} Inverter compressor start at 30hz^{20s later} Fix scroll
 compressor start(This step is omitted for 8HP&10HP models)^{40s later} Inverter compressor running
 frequency will adjust according the capacity requirement.

4. Electric Characteristics

System HP	Outdoor Unit				Power Current			Compressor		OFM	
	Hz	Voltage	Min.	Max.	MCA	TOCA	MFA	MSC	RLA	KW	FLA
8HP	50	380~415	342	440	18.4	20.8	25	-	17.4	0.42	4.4
10HP	50	380~415	342	440	20.6	22.1	25	-	17.4	0.42	4.4
12HP	50	380~415	342	440	24.1	23.7	25	-/68	10.5+9.6	0.42	4.4
14HP	50	380~415	342	440	28.9	31.8	35	-/64	17.4+8.8	0.42+0.38	4.2+2.9
16HP	50	380~415	342	440	32.4	32.8	35	-/68	17.4+9.6	0.42+0.38	4.2+2.9
18HP	50	380~415	342	440	35.8	40.7	45	-/85	17.4+12	0.42+0.38	4.2+2.9

The current value of combination unit is the total value of each basic model(refer to Units Combination Table in Part1)

For example: 46HP=18HP+18HP+10HP

Power current: MCA=35.8+35.8+20.6=92.2

TOCA=40.7+40.7+22.1=103.5

MFA=45+45+25=115

Compressor: RLA=17.4+12+17.4+12+17.4=76.2

OFM: FLA=4.2+2.9+4.2+2.9+4.4=18.6

Remark:

MCA: Min. Current Amps. (A)

TOCA: Total Over-current Amps. (A)

MFA: Max. Fuse Amps. (A)

MSC: Max. Starting Amps. (A)

RLA: Rated Load Amps. (A)

OFM: Outdoor Fan Motor.

FLA: Full Load Amps. (A)

KW: Rated Motor Output (KW)

Notes:

1. RLA is based on the following conditions, Indoor temp. 27°C DB/19°C WB, Outdoor temp. 35°C DB
2. TOCA means the total value of each OC set.
3. MSC means the Max. current during the starting of compressor.
4. Voltage range. Units are suitable for use on electrical systems where voltage supplied to unit terminals is not below or above listed range limits.
5. Maximum allowable voltage variation between phases is 2%
6. Selection wire size based on the larger value of MCA or TOCA
7. MFA is used to select the circuit breaker and the ground fault circuit interrupter (earth circuit breaker).

5. Wiring Diagrams and Field Wiring

5.1 Wiring Diagrams for 8~16HP

Code	Name
COMP (INV)	Inverter compressor
COMP FIX1	Fixed compressor
FAN1	DC fan
FAN2	AC fan
ST1/ST2	Main/Auxiliary 4-way valve
MM(L,B)	Contactor
XT1	Middle terminal
Y72	4-phase terminal
P-R90	Discharge Temp. protect switch
L-R90	Low pressure ON/OFF switch
H-R90	High pressure ON/OFF switch
EXV_A, EXV_B	Electronic expansion valve
XST-358	Middle terminal
XP-Y98	Middle terminal
T3	Condenser pipe Temp. sensor
T4	Outdoor Temp. sensor
T701	Inverter compressor discharge Temp. sensor
T702	Fix. (8,10HP) Inverter compressor discharge Temp. sensor
H-VL1	Pressure sensor
PTC	Thermistor
CT1, CT2, IZ22	Current inductor
TRANS1, TRANS2	Power transformer
DS92	Single-phase rectifier bridge
BD-1	3-phase rectifier bridge
BD-3	3-phase rectifier bridge
CS	Fan capacitor
E1, E2, C4	Filter capacitor
L-3	Reactor
SV4-SV6	Solenoid valve
R1, R2	Current resistor
HEA (HEA, HEA1, HEA2)	Crankcase heater

DS92	Display Content
E0	Outdoor unit COM1 error
E1	Phase protection
E2	COM1 error with indoor unit
E3	Phase protection
E4	Refrigerant Temp. sensor error
E5	Low power protection
E6	Reserved
E7	Discharge Temp. sensor error
E8	Outdoor units address error
E9	Outdoor units address error
E10	Outdoor units address error
E11	COM1 error (DS92 & MPOS/MA128)
E12	COM1 error (DS92 & MPOS/MA128)
E13	Qty. of outdoor units decrease error
E14	Qty. of outdoor units increase error
E15	3 times of mobile protection in 60 min.
E16	3 times of mobile protection in 100 min.
E17	Qty. of indoor units cap. L match
E18	Pressure sensor error
E19	3 times of P2 protection in 60 min.
E20	3 times of P2 protection in 100 min.
P1	High pressure protection
P2	Low pressure protection
P3	Inverter compressor current protection
P4	High pressure protection
P5	High pressure protection
P6	High pressure protection
P7	Fixed compressor current protection
P8	Reserved
P9	DC fan mobile protection
C0	Compressor mobile protection
L1	Bus low voltage protection
L2	Bus low voltage protection
L3	Bus low voltage protection
L4	ME error/Synchronization/loss of 100%
L5	Zarcasness protection
L6	Phase sensor error
L7	Phase sensor error
L8	Frequency channel over 15Hz error
L9	Setting & actual frequency over 15Hz
df	Display content error
01	Display content error (frequency)
01	returning
d0	(DS92) display content error (frequency)

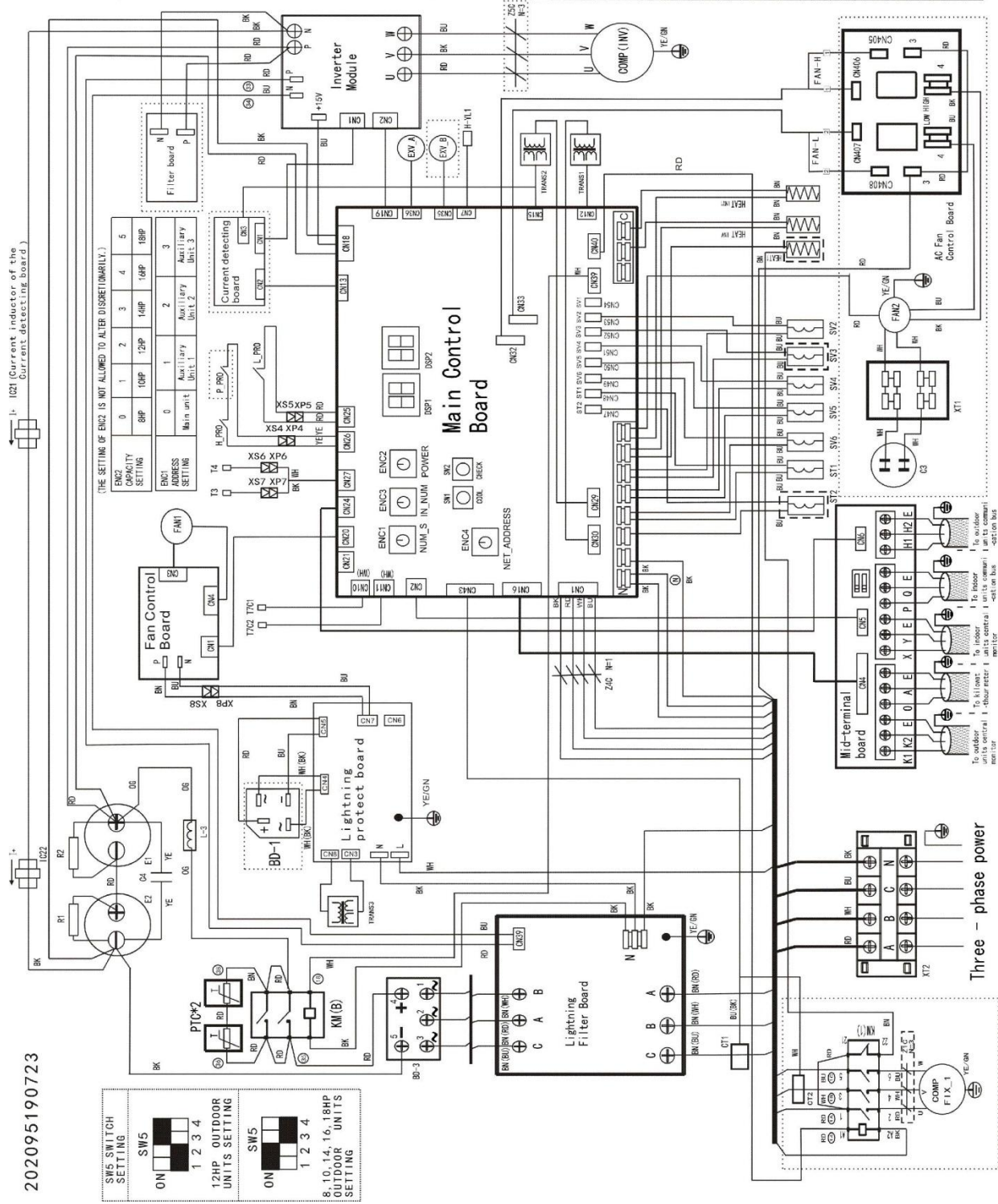

Wiring Diagrams for 18HP

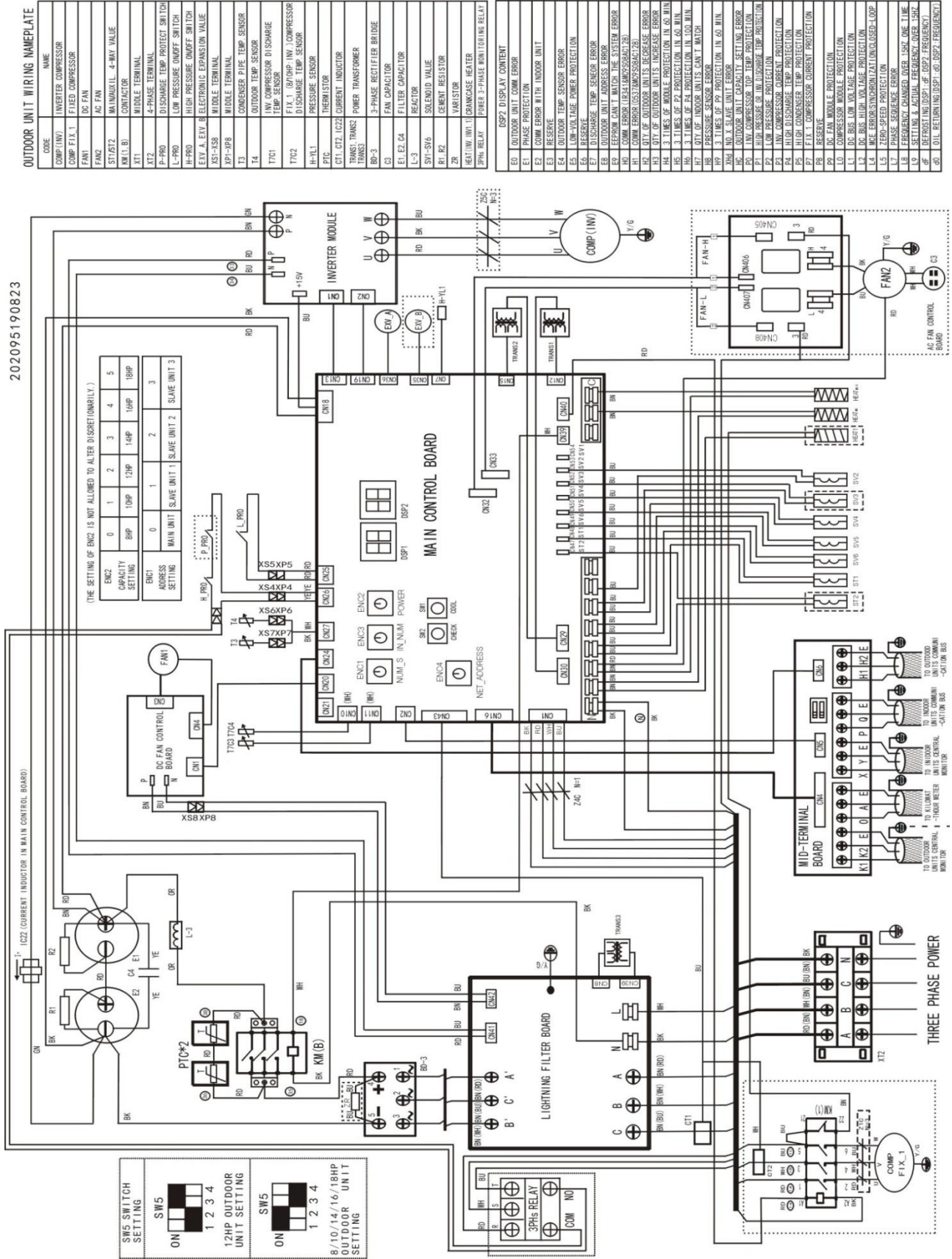

5.2 Field Wiring

a) Terminal of outdoor unit

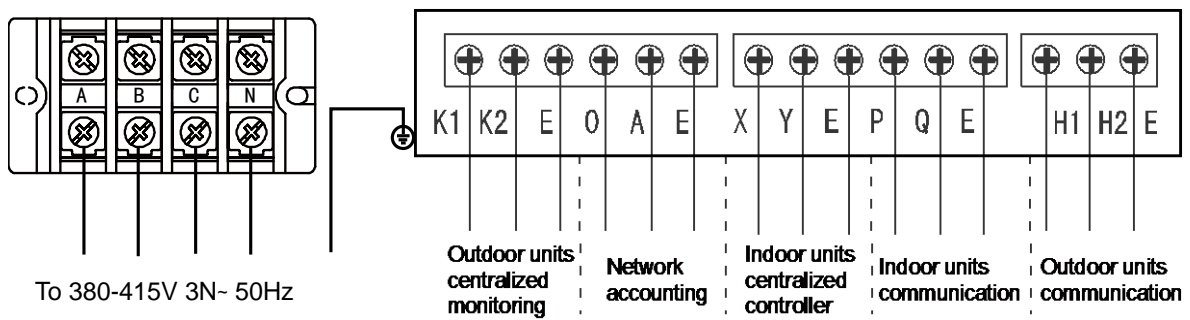

b) Wiring between Indoor and Outdoor unit

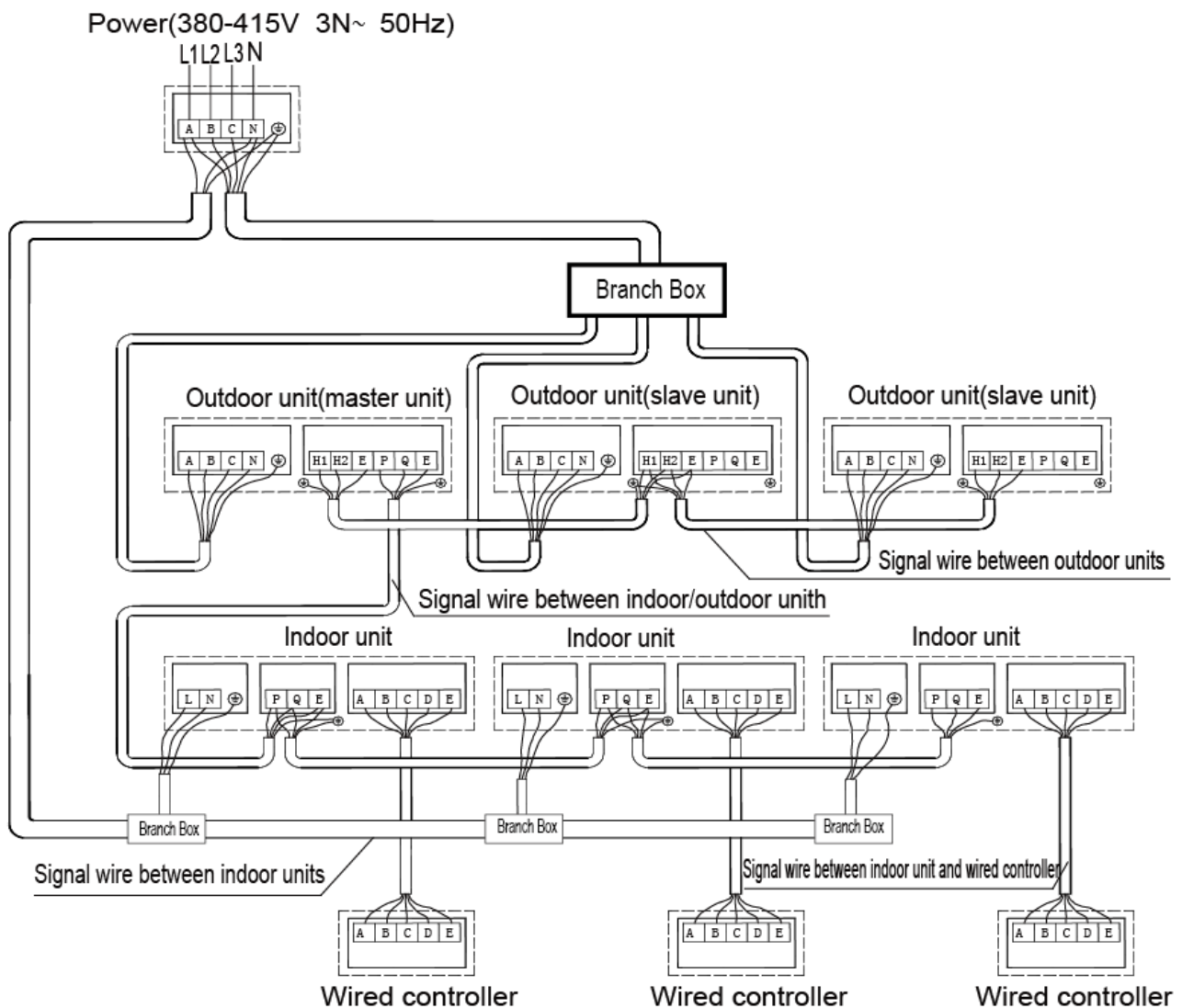

Note:

1. The signal connecting line between outdoor units, indoor and outdoor units and indoor units has polarity. When connecting, be careful to prevent error connection.
2. Signal line shall adopt three-core shielded wire with an area above 0.75 mm².
3. Do not bind signal line and copper pipe together with belting.
4. Make sure that the shield metal layer should be grounded well indoor control box in order to prevent interference.
5. It's forbidden to connect 200V or above high-volt live wire to the communication terminal.

6. Operation Limits

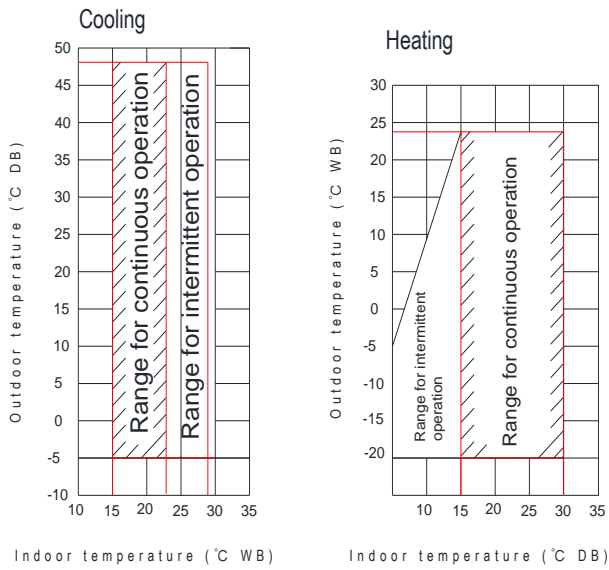

Notes:

1. If the system is running in cooling mode, when the ambient temperature is lower than -5°C or higher than 48°C , the units will stop running for protection control.

2. These figures base on the operation conditions between indoor units and outdoor units:

Equivalent pipe length is 5m, and height difference is 0m.

Precaution:

The indoor relative humidity should be lower than 80%. If the air conditioner works in an environment with a relative humidity higher than mentioned above, the surface of the air conditioner may condensate. In this case, it is recommended to set the air speed of the indoor unit to high.

7. Capacity Tables

8HP cooling mode

Combination (%) (Capacity index)	Outdoor temperature (°C DB)	Indoor temperature(°C DB/WD)													
		DB:20.8,WB:14		DB:23.3,WB:16		DB:25.8,WB:18		DB:27,WB:19		DB:28.2,WB:20		DB:30.7,WB:22		DB:32,WB:24	
		TC	PI	TC	PI	TC	PI	TC	PI	TC	PI	TC	PI	TC	PI
		kW	kW	kW	kW	kW	kW	kW	kW	kW	kW	kW	kW	kW	kW
130%	-5	22.14	2.40	26.37	2.93	30.60	3.14	31.77	3.27	33.30	3.36	34.11	3.66	34.97	3.68
	-2	22.14	2.40	26.37	2.99	30.60	3.14	31.77	3.29	33.30	3.36	34.11	3.70	34.97	3.72
	0	22.14	2.44	26.37	3.04	30.60	3.26	31.77	3.47	33.30	3.56	34.11	3.75	34.97	3.77
	2	22.14	2.49	26.37	3.05	30.60	3.37	31.77	3.66	33.30	3.60	34.11	3.78	34.97	3.82
	4	22.14	2.54	26.37	3.11	30.60	3.48	31.77	3.68	33.30	3.65	34.11	3.77	34.97	3.89
	6	22.14	2.59	26.37	3.17	30.60	3.61	31.77	3.71	32.93	3.76	33.69	3.77	34.58	3.92
	8	22.14	2.65	26.37	3.24	30.60	3.79	31.77	3.89	32.52	3.88	33.33	3.90	34.14	3.96
	10	22.14	2.71	26.37	3.31	30.60	3.93	31.77	4.02	32.13	4.04	32.94	4.06	33.75	4.08
	12	22.14	2.76	26.37	3.37	30.60	4.01	31.32	4.03	31.77	4.06	32.49	4.07	33.30	4.10
	14	22.14	2.81	26.37	3.44	30.51	4.05	30.96	4.06	31.32	4.08	32.13	4.09	32.94	4.19
	16	22.14	2.86	26.37	3.51	30.15	4.06	30.51	4.08	30.87	4.10	31.68	4.12	32.49	4.26
	18	22.14	2.91	26.37	3.58	29.70	4.20	30.06	4.22	30.51	4.24	31.32	4.28	32.13	4.32
	20	22.14	2.98	26.37	3.81	29.25	4.40	29.70	4.43	30.06	4.45	30.87	4.49	31.68	4.54
	21	22.14	3.06	26.37	3.94	29.07	4.51	29.52	4.53	29.88	4.55	30.69	4.60	31.50	4.64
	23	22.14	3.28	26.37	4.23	28.71	4.71	29.07	4.73	29.43	4.76	30.24	4.81	31.05	4.85
	25	22.14	3.50	26.37	4.53	28.26	4.92	28.62	4.94	29.07	4.97	29.88	5.02	30.69	5.07
	27	22.14	3.74	26.37	4.85	27.90	5.12	28.26	5.15	28.62	5.18	29.43	5.23	30.24	5.29
	29	22.14	3.99	26.37	5.18	27.45	5.33	27.81	5.36	28.26	5.39	29.07	5.45	29.88	5.50
	31	22.14	4.26	26.28	5.48	27.00	5.54	27.45	5.57	27.81	5.60	28.62	5.66	29.43	5.72
	33	22.14	4.54	25.83	5.68	26.64	5.75	27.00	5.78	27.45	5.81	28.26	5.87	28.98	5.94
	35	22.14	4.84	25.38	5.89	26.19	5.96	26.64	5.99	27.00	6.03	27.81	6.10	28.62	6.16
	37	22.14	5.15	25.02	6.10	25.83	6.18	26.19	6.21	26.64	6.25	27.36	6.32	28.17	6.39
39	22.14	5.48	24.57	6.17	25.38	6.38	25.83	6.42	26.19	6.46	27.00	6.53	27.81	6.61	
41	22.14	5.77	24.32	6.23	25.11	6.44	25.56	6.48	25.92	6.52	26.73	6.54	26.74	6.67	
43	22.14	5.91	24.14	6.26	24.98	6.46	25.43	6.51	25.66	6.53	26.25	6.56	26.42	6.69	
45	22.14	6.21	23.99	6.32	24.71	6.52	25.16	6.55	25.28	6.56	25.53	6.58	25.91	6.81	
48	22.14	6.43	24.84	6.52	26.94	6.58	27.44	6.61	27.66	6.63	27.54	6.69	28.04	6.71	
120%	-5	20.43	2.32	24.30	2.81	28.26	3.32	30.24	3.62	31.68	3.78	32.40	3.90	33.12	4.00
	-2	20.43	2.34	24.30	2.84	28.26	3.35	30.24	3.64	31.68	3.82	32.40	3.93	33.12	4.01
	0	20.43	2.36	24.30	2.86	28.26	3.39	30.24	3.65	31.68	3.85	32.40	3.95	33.12	4.02
	2	20.43	2.37	24.30	2.89	28.26	3.42	30.24	3.69	31.68	3.87	32.40	3.98	33.12	4.03
	4	20.43	2.39	24.30	2.92	28.26	3.46	30.24	3.72	31.68	3.92	32.40	3.99	33.12	4.04
	6	20.43	2.42	24.30	2.95	28.26	3.51	30.24	3.76	31.68	3.96	32.40	4.02	33.12	4.05
	8	20.43	2.44	24.30	2.98	28.26	3.55	30.24	3.81	31.68	4.00	32.40	4.04	33.12	4.07
	10	20.43	2.47	24.30	3.02	28.26	3.59	30.24	3.88	31.68	4.01	32.40	4.05	33.12	4.09
	12	20.43	2.52	24.30	3.07	28.26	3.66	30.24	3.95	31.23	4.02	31.95	4.03	32.67	4.12
	14	20.43	2.57	24.30	3.14	28.26	3.73	30.24	4.03	30.78	4.05	31.59	4.09	32.31	4.17
	16	20.43	2.61	24.30	3.20	28.26	3.80	30.06	4.10	30.42	4.11	31.14	4.16	31.86	4.23
	18	20.43	2.66	24.30	3.26	28.26	3.93	29.61	4.20	29.97	4.21	30.69	4.25	31.50	4.29
	20	20.43	2.72	24.30	3.39	28.26	4.23	29.25	4.40	29.61	4.42	30.33	4.46	31.05	4.50
	21	20.43	2.74	24.30	3.51	28.26	4.38	28.98	4.50	29.34	4.52	30.15	4.56	30.87	4.61
	23	20.43	2.93	24.30	3.76	28.26	4.69	28.62	4.70	28.98	4.73	29.70	4.77	30.42	4.81
	25	20.43	3.13	24.30	4.02	27.81	4.89	28.17	4.91	28.53	4.93	29.34	4.98	30.06	5.03
	27	20.43	3.34	24.30	4.30	27.45	5.09	27.81	5.12	28.17	5.15	28.89	5.19	29.61	5.24
	29	20.43	3.56	24.30	4.59	27.00	5.30	27.36	5.33	27.72	5.35	28.44	5.41	29.25	5.45
	31	20.43	3.80	24.30	4.90	26.55	5.51	27.00	5.53	27.36	5.57	28.08	5.62	28.80	5.68
	33	20.43	4.05	24.30	5.23	26.19	5.72	26.55	5.75	26.91	5.77	27.63	5.83	28.35	5.89
	35	20.43	4.31	24.30	5.57	25.74	5.92	26.10	5.95	26.55	5.98	27.27	6.05	27.99	6.11
	37	20.43	4.58	24.30	5.94	25.38	6.14	25.74	6.17	26.10	6.20	26.82	6.26	27.54	6.33
39	20.43	4.88	24.21	6.27	24.93	6.34	25.29	6.38	25.65	6.41	26.46	6.48	27.18	6.55	
41	20.43	5.01	24.01	6.31	24.73	6.39	25.09	6.43	25.45	6.46	26.26	6.50	26.40	6.60	
43	20.43	5.08	23.89	6.36	24.54	6.42	24.90	6.45	25.26	6.48	25.81	6.52	25.99	6.73	
45	20.43	5.14	23.76	6.42	24.30	6.48	24.64	6.51	25.04	6.53	25.29	6.54	25.73	6.87	
48	23.67	5.19	27.29	6.49	27.80	6.54	28.09	6.56	28.69	6.58	28.84	6.56	29.42	6.96	
110%	-5	18.72	2.02	22.32	2.52	25.92	3.01	27.72	3.23	29.52	3.47	31.77	3.61	32.49	3.72
	-2	18.72	2.06	22.32	2.55	25.92	3.03	27.72	3.26	29.52	3.50	31.77	3.64	32.49	3.74
	0	18.72	2.08	22.32	2.57	25.92	3.06	27.72	3.28	29.52	3.54	31.77	3.68	32.49	3.78
	2	18.72	2.13	22.32	2.59	25.92	3.10	27.72	3.32	29.52	3.58	31.77	3.73	32.49	3.83
	4	18.72	2.17	22.32	2.62	25.92	3.13	27.72	3.36	29.52	3.63	31.77	3.78	32.49	3.87

	6	18.72	2.19	22.32	2.65	25.92	3.16	27.72	3.41	29.52	3.67	31.77	3.82	32.49	3.93
	8	18.72	2.21	22.32	2.69	25.92	3.20	27.72	3.45	29.52	3.72	31.77	3.85	32.49	3.97
	10	18.72	2.24	22.32	2.73	25.92	3.25	27.72	3.51	29.52	3.78	31.77	3.88	32.49	4.00
	12	18.72	2.29	22.32	2.79	25.92	3.31	27.72	3.58	29.52	3.85	31.41	3.93	32.04	4.05
	14	18.72	2.33	22.32	2.83	25.92	3.37	27.72	3.64	29.52	3.92	30.96	3.97	31.68	4.08
	16	18.72	2.37	22.32	2.89	25.92	3.44	27.72	3.71	29.52	4.00	30.60	4.01	31.23	4.13
	18	18.72	2.41	22.32	2.95	25.92	3.51	27.72	3.82	29.52	4.19	30.15	4.22	30.87	4.26
	20	18.72	2.46	22.32	3.01	25.92	3.71	27.72	4.10	29.07	4.39	29.79	4.43	30.42	4.47
	21	18.72	2.49	22.32	3.10	25.92	3.85	27.72	4.25	28.89	4.50	29.52	4.53	30.24	4.57
	23	18.72	2.60	22.32	3.32	25.92	4.12	27.72	4.56	28.44	4.69	29.16	4.74	29.79	4.78
	25	18.72	2.78	22.32	3.55	25.92	4.41	27.72	4.88	28.08	4.90	28.71	4.95	29.43	4.99
	27	18.72	2.96	22.32	3.79	25.92	4.72	27.27	5.09	27.63	5.11	28.35	5.15	28.98	5.20
	29	18.72	3.16	22.32	4.05	25.92	5.04	26.91	5.30	27.27	5.32	27.90	5.37	28.62	5.42
	31	18.72	3.36	22.32	4.31	25.92	5.38	26.46	5.50	26.82	5.53	27.54	5.57	28.17	5.63
	33	18.72	3.58	22.32	4.60	25.74	5.68	26.10	5.71	26.46	5.73	27.09	5.79	27.81	5.84
	35	18.72	3.81	22.32	4.90	25.29	5.88	25.65	5.91	26.01	5.95	26.64	6.00	27.36	6.06
	37	18.72	4.05	22.32	5.22	24.93	6.10	25.29	6.12	25.56	6.15	26.28	6.21	26.91	6.27
	39	18.72	4.31	22.32	5.56	24.48	6.30	24.84	6.33	25.20	6.37	25.83	6.43	26.55	6.49
	41	18.72	4.35	22.32	5.60	24.29	6.35	24.65	6.38	25.01	6.41	25.50	6.47	25.75	6.54
	43	18.72	4.40	22.32	5.67	24.10	6.39	24.46	6.42	24.82	6.45	25.28	6.50	25.36	6.67
	45	18.72	4.54	22.32	5.71	23.85	6.45	24.20	6.50	24.60	6.51	25.02	6.67	25.12	6.82
	48	20.50	4.70	24.45	6.19	25.74	6.49	26.08	6.55	26.63	6.58	26.95	6.70	27.16	6.90
100%	-5	17.01	1.84	20.25	2.22	23.58	2.64	25.20	2.83	26.82	3.07	30.15	3.50	31.86	3.65
	-2	17.01	1.87	20.25	2.25	23.58	2.67	25.20	2.88	26.82	3.11	30.15	3.54	31.86	3.68
	0	17.01	1.89	20.25	2.27	23.58	2.70	25.20	2.92	26.82	3.14	30.15	3.60	31.86	3.72
	2	17.01	1.92	20.25	2.30	23.58	2.73	25.20	2.96	26.82	3.18	30.15	3.65	31.86	3.78
	4	17.01	1.94	20.25	2.33	23.58	2.77	25.20	3.00	26.82	3.22	30.15	3.69	31.86	3.82
	6	17.01	1.96	20.25	2.37	23.58	2.81	25.20	3.05	26.82	3.27	30.15	3.74	31.86	3.88
	8	17.01	2.00	20.25	2.41	23.58	2.86	25.20	3.09	26.82	3.32	30.15	3.80	31.86	3.94
	10	17.01	2.03	20.25	2.45	23.58	2.91	25.20	3.14	26.82	3.38	30.15	3.86	31.86	4.00
	12	17.01	2.06	20.25	2.50	23.58	2.96	25.20	3.20	26.82	3.44	30.15	3.93	31.41	4.03
	14	17.01	2.10	20.25	2.55	23.58	3.02	25.20	3.26	26.82	3.51	30.15	4.01	31.05	4.08
	16	17.01	2.14	20.25	2.60	23.58	3.08	25.20	3.32	26.82	3.58	29.97	4.06	30.60	4.12
	18	17.01	2.18	20.25	2.64	23.58	3.13	25.20	3.39	26.82	3.65	29.61	4.20	30.24	4.23
	20	17.01	2.22	20.25	2.70	23.58	3.23	25.20	3.56	26.82	3.91	29.16	4.39	29.79	4.43
	21	17.01	2.24	20.25	2.72	23.58	3.35	25.20	3.69	26.82	4.05	28.98	4.50	29.61	4.54
	23	17.01	2.30	20.25	2.91	23.58	3.59	25.20	3.95	26.82	4.34	28.62	4.70	29.16	4.74
	25	17.01	2.45	20.25	3.10	23.58	3.84	25.20	4.24	26.82	4.65	28.17	4.91	28.80	4.95
	27	17.01	2.61	20.25	3.31	23.58	4.10	25.20	4.53	26.82	4.97	27.72	5.11	28.35	5.16
	29	17.01	2.78	20.25	3.53	23.58	4.38	25.20	4.84	26.73	5.28	27.36	5.33	27.99	5.37
	31	17.01	2.96	20.25	3.77	23.58	4.67	25.20	5.16	26.37	5.49	26.91	5.53	27.54	5.58
	33	17.01	3.14	20.25	4.01	23.58	4.98	25.20	5.51	25.92	5.69	26.55	5.74	27.18	5.79
	35	17.01	3.34	20.25	4.27	23.58	5.31	25.20	5.87	25.47	5.90	26.10	5.95	26.73	6.00
	37	17.01	3.55	20.25	4.54	23.58	5.66	24.75	6.08	25.11	6.11	25.74	6.17	26.28	6.21
39	17.01	3.78	20.25	4.83	23.58	6.02	24.39	6.29	24.66	6.32	25.29	6.37	25.92	6.44	
41	17.01	3.95	20.25	5.01	23.58	6.24	24.01	6.33	24.47	6.41	24.85	6.52	25.54	6.57	
43	17.01	4.13	20.25	5.18	23.58	6.36	23.63	6.40	24.29	6.48	25.00	6.57	25.09	6.64	
45	17.01	4.36	20.25	5.42	23.58	6.47	23.13	6.49	24.17	6.59	24.79	6.67	24.59	6.73	
48	17.62	4.56	20.97	5.61	24.42	6.48	22.97	6.57	24.99	6.71	24.11	6.74	24.91	6.79	
90%	-5	15.30	1.63	18.27	1.96	21.24	2.31	22.68	2.52	24.12	2.68	27.09	3.08	30.06	3.53
	-2	15.30	1.65	18.27	1.98	21.24	2.34	22.68	2.55	24.12	2.71	27.09	3.11	30.06	3.56
	0	15.30	1.67	18.27	2.00	21.24	2.37	22.68	2.58	24.12	2.75	27.09	3.15	30.06	3.59
	2	15.30	1.70	18.27	2.03	21.24	2.40	22.68	2.62	24.12	2.79	27.09	3.21	30.06	3.64
	4	15.30	1.72	18.27	2.06	21.24	2.44	22.68	2.66	24.12	2.83	27.09	3.26	30.06	3.70
	6	15.30	1.75	18.27	2.10	21.24	2.48	22.68	2.71	24.12	2.88	27.09	3.31	30.06	3.76
	8	15.30	1.78	18.27	2.14	21.24	2.53	22.68	2.75	24.12	2.93	27.09	3.37	30.06	3.79
	10	15.30	1.81	18.27	2.18	21.24	2.58	22.68	2.79	24.12	2.99	27.09	3.42	30.06	3.85
	12	15.30	1.84	18.27	2.22	21.24	2.63	22.68	2.83	24.12	3.05	27.09	3.48	30.06	3.93
	14	15.30	1.88	18.27	2.26	21.24	2.68	22.68	2.89	24.12	3.10	27.09	3.55	30.06	4.00
	16	15.30	1.91	18.27	2.30	21.24	2.73	22.68	2.94	24.12	3.17	27.09	3.62	29.97	4.07
	18	15.30	1.94	18.27	2.35	21.24	2.78	22.68	3.00	24.12	3.23	27.09	3.69	29.61	4.20
	20	15.30	1.98	18.27	2.40	21.24	2.83	22.68	3.06	24.12	3.35	27.09	3.97	29.16	4.39
21	15.30	1.99	18.27	2.42	21.24	2.88	22.68	3.17	24.12	3.47	27.09	4.11	28.98	4.50	
23	15.30	2.03	18.27	2.52	21.24	3.09	22.68	3.40	24.12	3.72	27.09	4.41	28.53	4.70	
25	15.30	2.15	18.27	2.69	21.24	3.30	22.68	3.63	24.12	3.97	27.09	4.72	28.17	4.91	

	27	15.30	2.28	18.27	2.87	21.24	3.52	22.68	3.88	24.12	4.25	27.09	5.05	27.72	5.11
	29	15.30	2.43	18.27	3.06	21.24	3.76	22.68	4.14	24.12	4.54	26.82	5.28	27.36	5.32
	31	15.30	2.58	18.27	3.25	21.24	4.01	22.68	4.42	24.12	4.84	26.37	5.49	26.91	5.53
	33	15.30	2.74	18.27	3.46	21.24	4.27	22.68	4.71	24.12	5.17	26.01	5.70	26.55	5.74
	35	15.30	2.91	18.27	3.68	21.24	4.55	22.68	5.02	24.12	5.51	25.56	5.91	26.10	5.95
	37	15.30	3.09	18.27	3.91	21.24	4.84	22.68	5.34	24.12	5.87	25.11	6.11	25.74	6.16
	39	15.30	3.28	18.27	4.16	21.24	5.15	22.68	5.69	24.12	6.25	24.75	6.33	25.29	6.37
	41	15.30	3.39	18.27	4.35	21.24	5.34	22.68	5.84	24.12	6.29	24.58	6.49	25.12	6.52
	43	15.30	3.55	18.27	4.54	21.24	5.53	22.68	5.99	24.12	6.43	24.45	6.57	24.90	6.62
	45	15.30	3.78	18.27	4.77	21.24	5.76	22.68	6.19	24.12	6.60	24.32	6.64	24.52	6.71
	48	15.30	3.99	18.27	4.99	21.24	5.97	22.68	6.27	24.12	6.66	26.79	6.73	26.51	6.80
80%	-5	13.59	1.44	16.20	1.70	18.81	2.01	20.16	2.14	21.51	2.30	24.12	2.66	26.73	3.04
	-2	13.59	1.46	16.20	1.72	18.81	2.03	20.16	2.17	21.51	2.33	24.12	2.69	26.73	3.07
	0	13.59	1.48	16.20	1.74	18.81	2.05	20.16	2.20	21.51	2.37	24.12	2.73	26.73	3.11
	2	13.59	1.51	16.20	1.77	18.81	2.08	20.16	2.24	21.51	2.41	24.12	2.78	26.73	3.17
	4	13.59	1.54	16.20	1.80	18.81	2.12	20.16	2.29	21.51	2.45	24.12	2.83	26.73	3.21
	6	13.59	1.56	16.20	1.84	18.81	2.16	20.16	2.34	21.51	2.50	24.12	2.87	26.73	3.27
	8	13.59	1.59	16.20	1.88	18.81	2.21	20.16	2.38	21.51	2.55	24.12	2.92	26.73	3.33
	10	13.59	1.61	16.20	1.92	18.81	2.26	20.16	2.44	21.51	2.61	24.12	2.98	26.73	3.36
	12	13.59	1.63	16.20	1.96	18.81	2.30	20.16	2.49	21.51	2.67	24.12	3.04	26.73	3.43
	14	13.59	1.66	16.20	1.99	18.81	2.34	20.16	2.53	21.51	2.72	24.12	3.10	26.73	3.49
	16	13.59	1.69	16.20	2.03	18.81	2.39	20.16	2.57	21.51	2.76	24.12	3.16	26.73	3.55
	18	13.59	1.72	16.20	2.07	18.81	2.44	20.16	2.63	21.51	2.82	24.12	3.22	26.73	3.63
	20	13.59	1.75	16.20	2.11	18.81	2.49	20.16	2.68	21.51	2.87	24.12	3.34	26.73	3.88
	21	13.59	1.77	16.20	2.12	18.81	2.51	20.16	2.71	21.51	2.94	24.12	3.46	26.73	4.02
	23	13.59	1.80	16.20	2.17	18.81	2.63	20.16	2.88	21.51	3.14	24.12	3.70	26.73	4.31
	25	13.59	1.85	16.20	2.30	18.81	2.81	20.16	3.08	21.51	3.36	24.12	3.97	26.73	4.62
	27	13.59	1.97	16.20	2.45	18.81	2.99	20.16	3.29	21.51	3.59	24.12	4.24	26.73	4.94
	29	13.59	2.10	16.20	2.61	18.81	3.19	20.16	3.50	21.51	3.83	24.12	4.52	26.73	5.28
	31	13.59	2.22	16.20	2.78	18.81	3.40	20.16	3.73	21.51	4.09	24.12	4.83	26.28	5.49
	33	13.59	2.37	16.20	2.95	18.81	3.62	20.16	3.97	21.51	4.35	24.12	5.15	25.92	5.69
	35	13.59	2.51	16.20	3.14	18.81	3.85	20.16	4.23	21.51	4.63	24.12	5.49	25.47	5.90
	37	13.59	2.66	16.20	3.33	18.81	4.09	20.16	4.50	21.51	4.93	24.12	5.85	25.11	6.10
	39	13.59	2.82	16.20	3.55	18.81	4.35	20.16	4.79	21.51	5.25	24.12	6.23	24.66	6.32
	41	13.59	2.88	16.20	3.59	18.81	4.42	20.16	4.92	21.51	5.34	24.12	6.39	24.51	6.43
43	13.59	2.97	16.20	3.62	18.81	4.48	20.16	5.00	21.51	5.42	24.12	6.46	24.36	6.50	
45	13.59	3.05	16.20	3.66	18.81	4.57	20.16	5.11	21.51	5.51	24.12	6.53	24.05	6.60	
48	13.59	3.15	16.20	3.69	21.16	4.64	20.16	5.18	21.51	5.56	24.12	6.60	26.83	6.69	
70%	-5	11.88	1.28	14.22	1.50	16.47	1.70	17.64	1.83	18.81	1.95	21.06	2.23	23.40	2.57
	-2	11.88	1.29	14.22	1.51	16.47	1.72	17.64	1.86	18.81	1.99	21.06	2.27	23.40	2.60
	0	11.88	1.30	14.22	1.53	16.47	1.75	17.64	1.90	18.81	2.02	21.06	2.31	23.40	2.64
	2	11.88	1.31	14.22	1.54	16.47	1.78	17.64	1.93	18.81	2.06	21.06	2.36	23.40	2.68
	4	11.88	1.33	14.22	1.58	16.47	1.82	17.64	1.97	18.81	2.10	21.06	2.40	23.40	2.74
	6	11.88	1.35	14.22	1.61	16.47	1.86	17.64	2.03	18.81	2.15	21.06	2.44	23.40	2.79
	8	11.88	1.37	14.22	1.65	16.47	1.91	17.64	2.06	18.81	2.20	21.06	2.51	23.40	2.85
	10	11.88	1.40	14.22	1.68	16.47	1.96	17.64	2.11	18.81	2.26	21.06	2.56	23.40	2.88
	12	11.88	1.43	14.22	1.70	16.47	2.00	17.64	2.15	18.81	2.30	21.06	2.61	23.40	2.94
	14	11.88	1.46	14.22	1.73	16.47	2.03	17.64	2.18	18.81	2.34	21.06	2.66	23.40	2.99
	16	11.88	1.48	14.22	1.77	16.47	2.07	17.64	2.22	18.81	2.38	21.06	2.71	23.40	3.05
	18	11.88	1.50	14.22	1.80	16.47	2.11	17.64	2.26	18.81	2.42	21.06	2.76	23.40	3.11
	20	11.88	1.53	14.22	1.83	16.47	2.15	17.64	2.30	18.81	2.47	21.06	2.82	23.40	3.20
	21	11.88	1.54	14.22	1.84	16.47	2.16	17.64	2.33	18.81	2.49	21.06	2.86	23.40	3.31
	23	11.88	1.57	14.22	1.88	16.47	2.21	17.64	2.41	18.81	2.62	21.06	3.06	23.40	3.55
	25	11.88	1.60	14.22	1.96	16.47	2.35	17.64	2.57	18.81	2.79	21.06	3.28	23.40	3.79
	27	11.88	1.69	14.22	2.08	16.47	2.51	17.64	2.74	18.81	2.98	21.06	3.50	23.40	4.05
	29	11.88	1.80	14.22	2.21	16.47	2.67	17.64	2.92	18.81	3.17	21.06	3.73	23.40	4.33
	31	11.88	1.90	14.22	2.34	16.47	2.84	17.64	3.10	18.81	3.38	21.06	3.97	23.40	4.62
	33	11.88	2.02	14.22	2.49	16.47	3.02	17.64	3.30	18.81	3.60	21.06	4.24	23.40	4.92
	35	11.88	2.14	14.22	2.64	16.47	3.21	17.64	3.52	18.81	3.83	21.06	4.51	23.40	5.25
	37	11.88	2.26	14.22	2.80	16.47	3.41	17.64	3.73	18.81	4.08	21.06	4.81	23.40	5.59
	39	11.88	2.39	14.22	2.97	16.47	3.62	17.64	3.97	18.81	4.33	21.06	5.11	23.40	5.95
	41	11.88	2.50	14.22	3.07	16.47	3.72	17.64	4.10	18.81	4.46	21.06	5.32	23.40	6.22
43	11.88	2.70	14.22	3.29	16.47	3.88	17.64	4.32	18.81	4.59	21.06	5.51	23.40	6.41	
45	11.88	2.76	14.22	3.36	16.47	3.96	17.64	4.39	18.81	4.82	21.06	5.81	23.40	6.66	
48	11.88	2.83	14.22	3.39	16.47	4.00	17.64	4.46	18.81	4.95	21.06	6.07	23.40	6.81	

60%	-5	10.17	1.09	12.15	1.27	14.13	1.48	15.12	1.58	16.11	1.70	18.09	1.91	20.07	2.19
	-2	10.17	1.10	12.15	1.29	14.13	1.51	15.12	1.60	16.11	1.72	18.09	1.94	20.07	2.21
	0	10.17	1.12	12.15	1.31	14.13	1.53	15.12	1.62	16.11	1.75	18.09	1.97	20.07	2.23
	2	10.17	1.14	12.15	1.34	14.13	1.55	15.12	1.65	16.11	1.77	18.09	2.01	20.07	2.26
	4	10.17	1.17	12.15	1.36	14.13	1.58	15.12	1.67	16.11	1.80	18.09	2.04	20.07	2.30
	6	10.17	1.18	12.15	1.39	14.13	1.61	15.12	1.71	16.11	1.83	18.09	2.08	20.07	2.35
	8	10.17	1.20	12.15	1.41	14.13	1.64	15.12	1.74	16.11	1.87	18.09	2.12	20.07	2.39
	10	10.17	1.23	12.15	1.44	14.13	1.67	15.12	1.79	16.11	1.91	18.09	2.16	20.07	2.42
	12	10.17	1.25	12.15	1.46	14.13	1.70	15.12	1.82	16.11	1.94	18.09	2.20	20.07	2.46
	14	10.17	1.27	12.15	1.49	14.13	1.73	15.12	1.85	16.11	1.98	18.09	2.24	20.07	2.51
	16	10.17	1.28	12.15	1.51	14.13	1.76	15.12	1.88	16.11	2.01	18.09	2.28	20.07	2.56
	18	10.17	1.31	12.15	1.54	14.13	1.79	15.12	1.92	16.11	2.05	18.09	2.32	20.07	2.60
	20	10.17	1.32	12.15	1.57	14.13	1.82	15.12	1.96	16.11	2.09	18.09	2.37	20.07	2.66
	21	10.17	1.34	12.15	1.58	14.13	1.84	15.12	1.97	16.11	2.11	18.09	2.39	20.07	2.68
	23	10.17	1.35	12.15	1.61	14.13	1.87	15.12	2.01	16.11	2.14	18.09	2.49	20.07	2.86
	25	10.17	1.38	12.15	1.63	14.13	1.94	15.12	2.11	16.11	2.28	18.09	2.65	20.07	3.05
	27	10.17	1.43	12.15	1.73	14.13	2.07	15.12	2.25	16.11	2.43	18.09	2.83	20.07	3.25
	29	10.17	1.51	12.15	1.84	14.13	2.20	15.12	2.39	16.11	2.59	18.09	3.02	20.07	3.47
	31	10.17	1.61	12.15	1.95	14.13	2.33	15.12	2.54	16.11	2.75	18.09	3.21	20.07	3.70
	33	10.17	1.69	12.15	2.07	14.13	2.48	15.12	2.70	16.11	2.93	18.09	3.41	20.07	3.94
35	10.17	1.80	12.15	2.19	14.13	2.63	15.12	2.87	16.11	3.11	18.09	3.63	20.07	4.20	
37	10.17	1.90	12.15	2.32	14.13	2.79	15.12	3.04	16.11	3.30	18.09	3.86	20.07	4.46	
39	10.17	2.00	12.15	2.45	14.13	2.95	15.12	3.22	16.11	3.51	18.09	4.10	20.07	4.75	
41	10.17	2.07	12.15	2.56	14.13	3.06	15.12	3.35	16.11	3.64	18.09	4.29	20.07	4.96	
43	10.17	2.13	12.15	2.67	14.13	3.17	15.12	3.45	16.11	3.76	18.09	4.48	20.07	5.18	
45	10.17	2.23	12.15	2.80	14.13	3.30	15.12	3.58	16.11	3.95	18.09	4.68	20.07	5.47	
48	10.17	2.32	12.15	2.93	14.13	3.41	15.12	3.67	16.11	4.10	18.09	4.85	20.07	5.72	
50%	-5	8.51	0.95	10.17	1.10	11.79	1.26	12.60	1.32	13.41	1.40	15.03	1.59	16.74	1.71
	-2	8.51	0.96	10.17	1.12	11.79	1.28	12.60	1.34	13.41	1.42	15.03	1.61	16.74	1.73
	0	8.51	0.97	10.17	1.14	11.79	1.30	12.60	1.36	13.41	1.44	15.03	1.63	16.74	1.76
	2	8.51	0.99	10.17	1.15	11.79	1.32	12.60	1.38	13.41	1.46	15.03	1.64	16.74	1.80
	4	8.51	1.00	10.17	1.17	11.79	1.34	12.60	1.40	13.41	1.49	15.03	1.68	16.74	1.84
	6	8.51	1.02	10.17	1.19	11.79	1.36	12.60	1.43	13.41	1.52	15.03	1.71	16.74	1.90
	8	8.51	1.04	10.17	1.21	11.79	1.38	12.60	1.46	13.41	1.54	15.03	1.74	16.74	1.96
	10	8.51	1.06	10.17	1.23	11.79	1.40	12.60	1.48	13.41	1.58	15.03	1.78	16.74	1.99
	12	8.51	1.07	10.17	1.24	11.79	1.42	12.60	1.51	13.41	1.61	15.03	1.81	16.74	2.02
	14	8.51	1.08	10.17	1.26	11.79	1.44	12.60	1.54	13.41	1.64	15.03	1.84	16.74	2.06
	16	8.51	1.10	10.17	1.27	11.79	1.46	12.60	1.57	13.41	1.66	15.03	1.88	16.74	2.09
	18	8.51	1.12	10.17	1.30	11.79	1.49	12.60	1.59	13.41	1.69	15.03	1.91	16.74	2.13
	20	8.51	1.13	10.17	1.31	11.79	1.51	12.60	1.61	13.41	1.73	15.03	1.94	16.74	2.17
	21	8.51	1.14	10.17	1.33	11.79	1.53	12.60	1.63	13.41	1.74	15.03	1.96	16.74	2.19
	23	8.51	1.16	10.17	1.35	11.79	1.55	12.60	1.66	13.41	1.77	15.03	1.99	16.74	2.24
	25	8.51	1.17	10.17	1.37	11.79	1.58	12.60	1.69	13.41	1.83	15.03	2.10	16.74	2.39
	27	8.51	1.20	10.17	1.42	11.79	1.67	12.60	1.80	13.41	1.94	15.03	2.23	16.74	2.55
	29	8.51	1.26	10.17	1.50	11.79	1.77	12.60	1.92	13.41	2.07	15.03	2.37	16.74	2.72
	31	8.51	1.33	10.17	1.59	11.79	1.88	12.60	2.03	13.41	2.19	15.03	2.52	16.74	2.89
	33	8.51	1.41	10.17	1.69	11.79	1.99	12.60	2.15	13.41	2.33	15.03	2.68	16.74	3.07
35	8.51	1.49	10.17	1.78	11.79	2.11	12.60	2.28	13.41	2.46	15.03	2.85	16.74	3.26	
37	8.51	1.57	10.17	1.88	11.79	2.23	12.60	2.41	13.41	2.61	15.03	3.02	16.74	3.47	
39	8.51	1.65	10.17	1.99	11.79	2.36	12.60	2.56	13.41	2.77	15.03	3.21	16.74	3.68	
41	8.51	1.72	10.17	2.07	11.79	2.44	12.60	2.68	13.41	2.89	15.03	3.38	16.74	3.85	
43	8.51	1.84	10.17	2.21	11.79	2.53	12.60	2.80	13.41	2.96	15.03	3.55	16.74	4.02	
45	8.51	1.88	10.17	2.27	11.79	2.70	12.60	3.01	13.41	3.09	15.03	3.89	16.74	4.36	
48	8.51	1.92	10.17	2.34	11.79	2.86	12.60	3.20	13.41	3.23	15.03	4.20	16.74	4.70	

8HP heating mode

Combination (Capacity index)	Outdoor air temp.		Indoor temperature(°C DB)											
			16		18		20		21		22		24	
	°C DB	°C WB	kW	PI	kW	PI	kW	PI	kW	PI	kW	PI	kW	PI
130%	-19.8	-20	17.48	4.34	17.40	4.65	17.32	4.96	17.32	5.11	17.23	5.26	17.23	5.57
	-18.8	-19	17.74	4.44	17.66	4.74	17.66	5.05	17.57	5.20	17.57	5.34	17.48	5.65
	-16.7	-17	18.43	4.65	18.34	4.94	18.26	5.23	18.26	5.37	18.26	5.52	18.17	5.81
	-13.7	-15	19.20	4.86	19.12	5.14	19.03	5.42	19.03	5.56	18.94	5.70	18.94	5.98
	-11.8	-13	19.97	5.08	19.97	5.35	19.89	5.61	19.80	5.75	19.80	5.89	19.71	6.15
	-9.8	-11	20.92	5.30	20.83	5.56	20.74	5.81	20.74	5.94	20.74	6.07	20.66	6.33
	-9.5	-10	21.43	5.42	21.34	5.66	21.26	5.91	21.26	6.04	21.17	6.16	21.17	6.41
	-8.5	-9.1	21.86	5.51	21.77	5.75	21.77	6.00	21.69	6.12	21.69	6.24	21.60	6.49
	-7	-7.6	22.63	5.67	22.63	5.91	22.54	6.14	22.54	6.26	22.46	6.37	22.37	6.61
	-5	-5.6	23.83	5.89	23.74	6.11	23.66	6.33	23.66	6.45	23.57	6.55	23.57	6.77
	-3	-3.7	24.94	6.08	24.86	6.29	24.86	6.50	24.77	6.61	24.77	6.72	24.68	6.92
	0	-0.7	26.91	6.37	26.91	6.57	26.83	6.76	26.83	6.84	26.74	6.96	26.74	7.16
	3	2.2	29.05	6.64	28.97	6.82	28.89	7.00	28.89	7.09	28.89	7.19	28.80	7.36
	5	4.1	30.51	6.80	30.43	6.98	30.43	7.15	30.34	7.24	30.34	7.32	30.26	7.49
	7	6	32.06	6.97	31.97	7.12	31.97	7.29	31.88	7.37	31.88	7.45	30.60	7.16
	9	7.9	33.68	7.11	33.60	7.27	33.60	7.42	33.51	7.50	32.83	7.34	30.60	6.72
11	9.8	35.40	7.25	35.31	7.40	35.14	7.49	33.94	7.20	32.83	6.90	30.60	6.33	
13	11.8	37.28	7.39	37.20	7.53	35.14	7.02	33.94	6.74	32.83	6.48	30.60	5.94	
15	13.7	39.08	7.52	37.37	7.13	35.14	6.61	33.94	6.36	32.83	6.10	30.60	5.61	
120%	-19.8	-20	17.40	4.76	17.31	5.04	17.23	5.33	17.23	5.46	17.23	5.61	17.14	5.89
	-18.8	-19	17.66	4.85	17.57	5.13	17.57	5.41	17.49	5.54	17.49	5.69	17.40	5.97
	-16.7	-17	18.34	5.04	18.26	5.31	18.14	5.57	18.17	5.71	18.17	5.85	18.09	6.11
	-13.7	-15	19.12	5.24	19.03	5.50	18.94	5.75	18.94	5.89	18.94	6.01	18.86	6.27
	-11.8	-13	19.89	5.44	19.89	5.69	19.80	5.93	19.80	6.06	19.72	6.18	19.72	6.43
	-9.8	-11	20.83	5.65	20.74	5.88	20.74	6.12	20.66	6.24	20.66	6.35	20.57	6.59
	-9.5	-10	21.35	5.75	21.26	5.98	21.17	6.21	21.17	6.33	21.17	6.44	21.09	6.67
	-8.5	-9.1	21.77	5.84	21.69	6.06	21.69	6.29	21.60	6.40	21.60	6.52	21.51	6.74
	-7	-7.6	22.54	5.99	22.54	6.21	22.46	6.42	22.46	6.53	22.37	6.64	22.37	6.85
	-5	-5.6	23.74	6.18	23.66	6.39	23.57	6.60	23.57	6.70	23.57	6.81	23.49	7.00
	-3	-3.7	24.86	6.37	24.86	6.57	24.77	6.76	24.77	6.85	24.69	6.96	24.69	7.15
	0	-0.7	26.83	6.64	26.83	6.82	26.74	7.00	26.74	7.09	26.66	7.18	26.66	7.36
	3	2.2	28.97	6.89	28.89	7.05	28.89	7.22	28.80	7.31	28.80	7.39	28.20	7.35
	5	4.1	30.43	7.04	30.34	7.20	30.34	7.36	30.26	7.44	30.26	7.52	28.20	6.90
	7	6	31.97	7.18	31.97	7.33	31.89	7.48	31.37	7.38	30.34	7.08	28.20	6.49
	9	7.9	33.60	7.32	33.52	7.47	32.40	7.22	31.37	6.93	30.34	6.65	28.20	6.11
11	9.8	35.31	7.45	34.46	7.32	32.40	6.79	31.37	6.53	30.34	6.26	28.20	5.76	
13	11.8	36.60	7.38	34.46	6.87	32.40	6.37	31.37	6.13	30.34	5.89	28.20	5.42	
15	13.7	36.60	6.95	34.46	6.47	32.40	6.01	31.37	5.77	30.34	5.55	28.20	5.11	
110%	-19.8	-20	17.31	5.18	17.23	5.43	17.14	5.69	17.14	5.82	17.15	5.95	17.06	6.21
	-18.8	-19	17.57	5.26	17.49	5.51	17.49	5.77	17.49	5.89	17.40	6.02	17.40	6.28
	-16.7	-17	18.26	5.43	18.17	5.68	18.43	5.93	18.09	6.05	18.09	6.17	18.00	6.41
	-13.7	-15	19.03	5.62	18.95	5.85	18.86	6.09	18.86	6.21	18.86	6.33	18.77	6.56
	-11.8	-13	19.80	5.81	19.80	6.03	19.71	6.25	19.71	6.37	19.63	6.48	19.63	6.71
	-9.8	-11	20.74	5.99	20.66	6.21	20.66	6.42	20.57	6.53	20.57	6.64	20.57	6.85
	-9.5	-10	21.26	6.09	21.17	6.29	21.08	6.51	21.08	6.61	21.08	6.72	21.00	6.93
	-8.5	-9.1	21.69	6.17	21.60	6.37	21.60	6.58	21.51	6.69	21.51	6.79	21.51	6.19
	-7	-7.6	22.46	6.31	22.46	6.50	22.37	6.70	22.37	6.80	22.37	6.90	22.29	7.10
	-5	-5.6	23.66	6.49	23.57	6.68	23.49	6.86	23.49	6.96	23.49	7.05	23.40	7.25
	-3	-3.7	24.77	6.65	24.77	6.83	24.69	7.01	24.69	7.10	24.60	7.19	24.60	7.37
	0	-0.7	26.74	6.90	26.74	7.07	26.66	7.24	26.66	7.32	26.66	7.40	25.89	7.26
	3	2.2	28.89	7.13	28.80	7.28	28.80	7.44	28.71	7.51	27.77	7.20	25.89	6.61
	5	4.1	30.34	7.27	30.34	7.42	29.74	7.35	28.71	7.05	27.77	6.77	25.89	6.21
	7	6	31.88	7.40	31.63	7.45	29.74	6.90	28.71	6.63	27.77	6.37	25.89	5.85
	9	7.9	33.51	7.52	31.63	7.00	29.74	6.49	28.71	6.24	27.77	5.99	25.89	5.51
11	9.8	33.51	7.08	31.63	6.59	29.74	6.11	28.71	5.88	27.77	5.65	25.89	5.20	
13	11.8	33.51	6.64	31.63	6.18	29.74	5.74	28.71	5.53	27.77	5.31	25.89	4.90	
15	13.7	33.51	5.89	31.63	5.83	29.74	5.42	28.71	5.22	27.77	5.02	25.89	4.63	
100%	-19.8	-20	17.23	5.59	17.14	5.82	17.14	6.06	17.06	6.18	17.06	6.29	16.97	6.53
	-18.8	-19	17.49	5.66	17.49	5.89	17.40	6.13	17.40	6.25	17.32	6.37	17.32	6.60
	-16.7	-17	18.17	5.82	18.08	6.05	18.08	6.27	18.00	6.38	18.00	6.49	18.00	6.72
	-13.7	-15	18.94	5.99	18.86	6.21	18.77	6.42	18.77	6.53	18.77	6.64	18.69	6.85

	-11.8	-13	19.72	6.17	19.72	6.37	19.63	6.57	19.63	6.68	19.63	6.78	19.54	6.99
	-9.8	-11	20.66	6.33	20.57	6.53	20.57	6.73	20.57	6.83	20.48	6.92	20.48	7.12
	-9.5	-10	21.17	6.42	21.09	6.61	21.09	6.80	21.00	6.90	21.00	7.00	20.91	7.19
	-8.5	-9.1	21.60	6.49	21.51	6.69	21.51	6.87	21.51	6.96	21.43	7.06	21.43	7.24
	-7	-7.6	22.37	6.62	22.37	6.80	22.29	6.98	22.29	7.08	22.29	7.16	22.20	7.35
	-5	-5.6	23.57	6.79	23.48	6.96	23.48	7.13	23.40	7.21	23.40	7.30	23.31	7.48
	-3	-3.7	24.69	6.94	24.69	6.30	24.60	7.27	24.60	7.35	24.60	7.43	23.57	7.12
	0	-0.7	26.66	7.16	26.66	7.32	26.57	7.47	26.14	7.35	25.29	7.04	23.57	6.46
	3	2.2	28.80	7.37	28.71	7.51	27.00	6.95	26.14	6.68	25.29	6.41	23.57	5.89
	5	4.1	30.26	7.51	28.71	7.05	27.00	6.53	26.14	6.29	25.29	6.04	23.57	5.55
	7	6	30.43	7.12	28.71	6.63	27.00	6.15	26.14	5.92	25.29	5.69	23.57	5.23
	9	7.9	30.43	6.69	28.71	6.24	27.00	5.79	26.14	5.50	25.29	5.36	23.57	4.94
	11	9.8	30.43	6.30	28.71	5.88	27.00	5.46	26.14	5.26	25.29	5.06	23.57	4.66
	13	11.8	30.43	5.92	28.71	5.53	27.00	5.14	26.14	4.95	25.29	4.77	23.57	4.40
	15	13.7	30.43	5.58	28.71	5.22	27.00	4.86	26.14	4.68	25.29	4.50	23.57	4.17
90%	-19.8	-20	17.11	6.01	17.03	6.21	17.03	6.43	16.94	6.53	16.94	6.64	16.94	6.85
	-18.8	-19	17.37	6.07	17.37	6.29	17.28	6.49	17.28	6.60	17.28	6.70	17.20	6.91
	-16.7	-17	18.05	6.22	17.97	6.42	17.97	6.62	17.97	6.72	17.88	6.82	17.88	7.02
	-13.7	-15	18.82	6.37	18.74	6.57	18.74	6.76	18.65	6.85	18.65	6.95	18.65	7.14
	-11.8	-13	19.59	6.53	19.59	6.71	19.51	6.89	19.51	6.99	19.51	7.08	19.42	7.26
	-9.8	-11	20.54	6.68	20.54	6.85	20.45	7.03	20.45	7.12	20.45	7.21	20.36	7.39
	-9.5	-10	21.05	6.76	20.96	6.93	20.96	7.10	20.88	7.19	20.88	7.28	20.88	7.44
	-8.5	-9.1	21.48	6.83	21.48	7.00	21.39	7.16	21.39	7.24	21.39	7.33	21.13	7.40
	-7	-7.6	22.25	6.94	22.25	7.10	22.16	7.27	22.16	7.35	22.16	7.43	21.13	7.07
	-5	-5.6	23.44	7.09	23.36	7.24	23.36	7.40	23.27	7.48	22.67	7.24	21.13	6.64
	-3	-3.7	24.56	7.23	24.56	7.37	24.30	7.40	23.44	7.11	22.67	6.82	21.13	6.26
	0	-0.7	26.61	7.44	25.84	7.25	24.30	6.72	23.44	6.45	22.67	6.20	21.13	5.69
	3	2.2	27.38	7.08	25.84	6.60	24.30	6.12	23.44	5.89	22.67	5.65	21.13	5.21
	5	4.1	27.38	6.66	25.84	6.21	24.30	5.77	23.44	5.54	22.67	5.34	21.13	4.91
	7	6	27.38	6.26	25.84	5.85	24.30	5.43	23.44	5.23	22.67	5.03	21.13	4.64
9	7.9	27.38	5.90	25.84	5.50	24.30	5.12	23.44	4.94	22.67	4.75	21.13	4.39	
11	9.8	27.38	5.56	25.84	5.19	24.30	4.84	23.44	4.66	22.67	4.49	21.13	4.15	
13	11.8	27.38	5.23	25.84	4.90	24.30	4.56	23.44	4.40	22.67	4.24	21.13	3.92	
15	13.7	27.38	4.94	25.84	4.62	24.30	4.32	23.44	4.17	22.67	4.02	21.13	3.72	
80%	-19.8	-20	17.06	6.42	16.97	6.61	16.97	6.80	16.97	6.89	16.88	6.99	16.88	7.17
	-18.8	-19	17.31	6.48	17.31	6.67	17.23	6.85	17.23	6.95	17.23	7.04	17.14	7.23
	-16.7	-17	18.00	6.61	17.92	6.79	17.92	6.97	17.92	7.06	17.92	7.15	17.83	7.32
	-13.7	-15	18.77	6.75	18.69	6.92	18.69	7.09	18.69	7.17	18.60	7.26	18.60	7.44
	-11.8	-13	19.54	6.88	19.54	7.05	19.46	7.21	19.46	7.29	19.46	7.38	18.86	7.18
	-9.8	-11	20.49	7.02	20.49	7.18	20.40	7.34	20.40	7.41	20.23	7.40	18.86	6.78
	-9.5	-10	21.00	7.09	20.91	7.24	20.92	7.40	20.92	7.48	20.23	7.18	18.86	6.58
	-8.5	-9.1	21.43	7.16	19.92	7.31	21.34	7.45	20.92	7.28	20.23	6.99	18.86	6.41
	-7	-7.6	22.20	7.26	22.20	7.40	21.60	7.24	20.92	6.96	20.23	6.68	18.86	6.13
	-5	-5.6	23.40	7.39	22.97	7.35	21.60	6.80	20.92	6.54	20.23	6.28	18.86	5.77
	-3	-3.7	24.34	7.43	22.97	6.92	21.60	6.41	20.92	6.17	20.23	5.92	18.86	5.45
	0	-0.7	24.34	6.74	22.97	6.28	21.60	5.83	20.92	5.61	20.23	5.39	18.86	4.97
	3	2.2	24.34	6.14	22.97	5.73	21.60	5.33	20.92	5.13	20.23	4.94	18.86	4.55
	5	4.1	24.34	5.78	22.97	5.40	21.60	5.02	20.92	4.84	20.23	4.66	18.86	4.30
	7	6	24.34	5.45	22.97	5.10	21.60	4.74	20.92	4.58	20.23	4.41	18.86	4.07
9	7.9	24.34	5.14	22.97	4.81	21.60	4.48	20.92	4.32	20.23	4.17	18.86	3.86	
11	9.8	24.34	4.86	22.97	4.54	21.60	4.24	20.92	4.09	20.23	3.95	18.86	3.66	
13	11.8	24.34	4.58	22.97	4.29	21.60	4.01	20.92	3.87	20.23	3.73	18.86	3.46	
15	13.7	24.34	4.33	22.97	4.07	21.60	3.80	20.92	3.67	20.23	3.54	18.86	3.29	
70%	-19.8	-20	16.93	6.84	16.85	7.00	16.85	7.16	16.85	7.24	16.85	7.33	16.42	7.25
	-18.8	-19	17.19	6.89	17.19	7.05	17.10	7.21	17.10	7.29	17.10	7.38	16.42	7.10
	-16.7	-17	17.87	7.00	17.87	7.16	17.79	7.32	17.79	7.40	17.62	6.59	16.42	6.77
	-13.7	-15	18.64	7.12	18.56	7.28	18.56	7.43	18.22	7.32	17.62	7.02	16.42	6.44
	-11.8	-13	19.41	7.24	19.41	7.39	18.90	7.21	18.22	6.93	17.62	6.65	16.42	6.10
	-9.8	-11	20.35	7.36	20.10	7.36	18.90	6.81	18.22	6.55	17.62	6.29	16.42	5.77
	-9.5	-10	20.87	7.43	20.10	7.14	18.90	6.61	18.22	6.36	17.62	6.11	16.42	5.61
	-8.5	-9.1	21.29	7.47	20.10	6.95	18.90	6.44	18.22	6.19	17.62	5.95	16.42	5.47
	-7	-7.6	21.29	7.13	20.10	6.64	18.90	6.16	18.22	5.93	17.62	5.69	16.42	5.24
	-5	-5.6	21.29	6.70	20.10	6.25	18.90	5.80	18.22	5.57	17.62	5.59	16.42	4.94
	-3	-3.7	21.29	6.31	20.10	5.89	18.90	5.47	18.22	5.26	17.62	5.06	16.42	4.67
	0	-0.7	21.29	5.74	20.10	5.37	18.90	4.99	18.22	4.81	17.62	4.63	16.42	4.28
3	2.2	21.29	5.25	20.10	4.91	18.90	4.58	18.22	4.41	17.62	4.25	16.42	3.93	

	5	4.1	21.29	4.95	20.10	4.63	18.90	4.33	18.22	4.17	17.62	4.02	16.42	3.72
	7	6	21.29	4.68	20.10	4.38	18.90	4.09	18.22	3.95	17.62	3.81	16.42	3.53
	9	7.9	21.29	4.42	20.10	4.15	18.90	3.87	18.22	3.74	17.62	3.61	16.42	3.35
	11	9.8	21.29	4.18	20.10	3.92	18.90	3.67	18.22	3.55	17.62	3.43	16.42	3.18
	13	11.8	21.29	3.95	20.10	3.71	18.90	3.47	18.22	3.36	17.62	3.24	16.42	3.02
	15	13.7	21.29	3.75	20.10	3.52	18.90	3.30	18.22	3.19	17.62	3.08	16.42	2.88
60%	-19.8	-20	16.89	7.25	16.80	7.39	16.20	7.11	15.69	6.83	15.17	6.56	14.14	6.01
	-18.8	-19	17.14	7.30	17.14	7.44	16.20	6.96	15.69	6.68	15.17	6.41	14.14	5.89
	-16.7	-17	17.83	7.40	17.23	7.16	16.20	6.64	15.69	6.38	15.17	6.13	14.14	5.63
	-13.7	-15	18.26	7.32	17.23	6.80	16.20	6.31	15.69	6.07	15.17	5.83	14.14	5.36
	-11.8	-13	18.26	6.92	17.23	6.44	16.20	5.98	15.69	5.76	15.17	5.53	14.14	5.12
	-9.8	-11	18.26	6.54	17.23	6.09	16.20	5.66	15.69	5.45	15.17	5.24	14.14	4.83
	-9.5	-10	18.26	6.36	17.23	5.93	16.20	5.50	15.69	5.30	15.17	5.10	14.14	4.70
	-8.5	-9.1	18.26	6.19	17.23	5.77	16.20	5.37	15.69	5.17	15.17	4.97	14.14	4.58
	-7	-7.6	18.26	5.92	17.23	5.53	16.20	5.14	15.69	4.95	15.17	4.76	14.14	4.40
	-5	-5.6	18.26	5.57	17.23	5.21	16.20	4.85	15.69	4.67	15.17	4.50	14.14	4.16
	-3	-3.7	18.26	5.26	17.23	4.92	16.20	4.58	15.69	4.42	15.17	4.26	14.14	3.94
	0	-0.7	18.26	4.81	17.23	4.50	16.20	4.20	15.69	4.06	15.17	3.91	14.14	3.62
	3	2.2	18.26	4.41	17.23	4.14	16.20	3.87	15.69	3.73	15.17	3.60	14.14	3.34
	5	4.1	18.26	4.17	17.23	3.91	16.20	3.66	15.69	3.54	15.17	3.41	14.14	3.17
	7	6	18.26	3.95	17.23	3.71	16.20	3.47	15.69	3.35	15.17	3.24	14.14	3.01
9	7.9	18.26	3.74	17.23	3.51	16.20	3.29	15.69	3.19	15.17	3.07	14.14	2.87	
11	9.8	18.26	3.55	17.23	3.34	16.20	3.13	15.69	3.03	15.17	2.92	14.14	2.73	
13	11.8	18.26	3.35	17.23	3.16	16.20	2.97	15.69	2.88	15.17	2.78	14.14	2.60	
15	13.7	18.26	3.19	17.23	3.00	16.20	2.83	15.69	2.74	15.17	2.65	14.14	2.48	
50%	-19.8	-20	15.21	6.60	14.35	6.14	13.50	5.70	12.99	5.49	12.56	5.28	11.71	4.86
	-18.8	-19	15.21	6.45	14.35	6.01	13.50	5.59	12.99	5.38	12.56	5.17	11.71	4.77
	-16.7	-17	15.21	6.16	14.35	5.74	13.50	5.34	12.99	5.14	12.56	4.95	11.71	4.57
	-13.7	-15	15.21	5.86	14.35	5.47	13.50	5.09	12.99	4.90	12.56	4.72	11.71	4.36
	-11.8	-13	15.21	5.57	14.35	5.20	13.50	4.84	12.99	4.66	12.56	4.49	11.71	4.15
	-9.8	-11	15.21	5.27	14.35	4.93	13.50	4.59	12.99	4.42	12.56	4.26	11.71	3.95
	-9.5	-10	15.21	5.13	14.35	4.79	13.50	4.47	12.99	4.31	12.56	4.15	11.71	3.84
	-8.5	-9.1	15.21	5.00	14.35	4.68	13.50	4.36	12.99	4.21	12.56	4.06	11.71	3.75
	-7	-7.6	15.21	4.79	14.35	4.49	13.50	4.18	12.99	4.04	12.56	3.90	11.71	3.61
	-5	-5.6	15.21	4.52	14.35	4.24	13.50	3.96	12.99	3.83	12.56	3.69	11.71	3.42
	-3	-3.7	15.21	4.28	14.35	4.02	13.50	3.75	12.99	3.63	12.56	3.50	11.71	3.25
	0	-0.7	15.21	3.93	14.35	3.69	13.50	3.46	12.99	3.34	12.56	3.23	11.71	3.00
	3	2.2	15.21	3.62	14.35	3.40	13.50	3.19	12.99	3.08	12.56	2.98	11.71	2.78
	5	4.1	15.21	3.43	14.35	3.23	13.50	3.03	12.99	2.93	12.56	2.84	11.71	2.64
	7	6	15.21	3.26	14.35	3.07	13.50	2.88	12.99	2.79	12.56	2.70	11.71	2.52
9	7.9	15.21	3.09	14.35	2.92	13.50	2.74	12.99	2.66	12.56	2.57	11.71	2.40	
11	9.8	15.21	2.94	14.35	2.77	13.50	2.61	12.99	2.53	12.56	2.45	11.71	2.29	
13	11.8	15.21	2.80	14.35	2.64	13.50	2.48	12.99	2.41	12.56	2.33	11.71	2.19	
15	13.7	15.21	2.66	14.35	2.52	13.50	2.37	12.99	2.30	12.56	2.23	11.71	2.09	

Note:

1. [shaded] is shown as reference.
2. The above table shows the average value of conditions may operate.
3. It is recommended to connect less than 130%.

10HP cooling mode

Combination (%) (Capacity index)	Outdoor temperature (°C DB)	Indoor temperature(°C DB/WD)													
		DB:20.8,WB:14		DB:23.3,WB:16		DB:25.8,WB:18		DB:27,WB:19		DB:28.2,WB:20		DB:30.7,WB:22		DB:32,WB:24	
		TC	PI	TC	PI	TC	PI	TC	PI	TC	PI	TC	PI	TC	PI
130%	-5	24.60	2.94	29.30	3.59	34.00	3.85	35.30	4.01	37.00	4.12	37.90	4.48	38.85	4.51
	-2	24.60	2.94	29.30	3.66	34.00	3.85	35.30	4.03	37.00	4.12	37.90	4.54	38.85	4.55
	0	24.60	2.99	29.30	3.72	34.00	3.99	35.30	4.25	37.00	4.36	37.90	4.59	38.85	4.61
	2	24.60	3.05	29.30	3.73	34.00	4.13	35.30	4.49	37.00	4.41	37.90	4.63	38.85	4.68
	4	24.60	3.11	29.30	3.80	34.00	4.27	35.30	4.51	37.00	4.47	37.90	4.62	38.85	4.77
	6	24.60	3.17	29.30	3.88	34.00	4.43	35.30	4.55	36.58	4.61	37.43	4.62	38.43	4.81
	8	24.60	3.25	29.30	3.97	34.00	4.65	35.30	4.77	36.13	4.76	37.03	3.90	37.93	4.85
	10	24.60	3.32	29.30	4.06	34.00	4.82	35.30	4.93	35.70	4.04	36.60	4.06	37.50	4.99
	12	24.60	3.38	29.30	4.13	34.00	4.92	34.80	4.03	35.30	4.06	36.10	4.07	37.00	5.03
	14	24.60	3.44	29.30	4.21	33.90	4.05	34.40	4.06	34.80	4.08	35.70	4.09	36.60	5.14
	16	24.60	3.50	29.30	4.30	33.50	4.06	33.90	4.08	34.30	4.10	35.20	4.12	36.10	5.22
	18	24.60	3.57	29.30	4.39	33.00	5.14	33.40	5.17	33.90	5.20	34.80	5.25	35.70	5.30
	20	24.60	3.65	29.30	4.67	32.50	5.39	33.00	5.42	33.40	5.45	34.30	5.50	35.20	5.56
	21	24.60	3.74	29.30	4.83	32.30	5.52	32.80	5.55	33.20	5.58	34.10	5.64	35.00	5.69
	23	24.60	4.02	29.30	5.18	31.90	5.77	32.30	5.80	32.70	5.83	33.60	5.89	34.50	5.95
	25	24.60	4.29	29.30	5.55	31.40	6.02	31.80	6.05	32.30	6.09	33.20	6.15	34.10	6.21
	27	24.60	4.58	29.30	5.94	31.00	6.28	31.40	6.32	31.80	6.34	32.70	6.41	33.60	6.48
	29	24.60	4.89	29.30	6.34	30.50	6.53	30.90	6.57	31.40	6.61	32.30	6.68	33.20	6.74
	31	24.60	5.22	29.20	6.71	30.00	6.79	30.50	6.83	30.90	6.86	31.80	6.94	32.70	7.01
	33	24.60	5.56	28.70	6.97	29.60	7.04	30.00	7.08	30.50	7.12	31.40	7.20	32.20	7.28
35	24.60	5.93	28.20	7.22	29.10	7.31	29.60	7.34	30.00	7.38	30.90	7.47	31.80	7.55	
37	24.60	6.31	27.80	7.48	28.70	7.57	29.10	7.61	29.60	7.65	30.40	7.74	31.30	7.83	
39	24.60	6.71	27.30	7.56	28.20	7.82	28.70	7.87	29.10	7.92	30.00	8.00	30.90	8.10	
41	24.60	7.07	27.02	7.63	27.90	7.89	28.40	7.94	28.80	7.99	29.70	8.02	29.71	8.17	
43	24.60	7.25	26.82	7.67	27.75	7.91	28.26	7.98	28.51	8.00	29.16	8.03	29.36	8.19	
45	24.60	7.61	26.65	7.74	27.46	7.99	27.96	8.03	28.09	8.04	28.37	8.06	28.78	8.35	
48	24.60	7.88	27.60	7.99	29.94	8.06	30.49	8.10	30.74	8.13	30.60	8.20	31.16	8.22	
120%	-5	22.70	2.84	27.00	3.44	31.40	4.07	33.60	4.44	35.20	4.63	36.00	4.78	36.80	4.90
	-2	22.70	2.87	27.00	3.48	31.40	4.11	33.60	4.46	35.20	4.68	36.00	4.81	36.80	4.92
	0	22.70	2.90	27.00	3.50	31.40	4.16	33.60	4.48	35.20	4.72	36.00	4.84	36.80	4.93
	2	22.70	2.90	27.00	3.54	31.40	4.19	33.60	4.52	35.20	4.74	36.00	4.88	36.80	4.94
	4	22.70	2.93	27.00	3.58	31.40	4.25	33.60	4.56	35.20	4.81	36.00	4.89	36.80	4.95
	6	22.70	2.96	27.00	3.61	31.40	4.30	33.60	4.61	35.20	4.86	36.00	4.93	36.80	4.97
	8	22.70	2.99	27.00	3.65	31.40	4.36	33.60	4.67	35.20	4.91	36.00	4.95	36.80	4.99
	10	22.70	3.03	27.00	3.70	31.40	4.39	33.60	4.75	35.20	4.91	36.00	4.96	36.80	5.01
	12	22.70	3.09	27.00	3.76	31.40	4.48	33.60	4.84	34.70	4.93	35.50	4.93	36.30	5.05
	14	22.70	3.14	27.00	3.84	31.40	4.57	33.60	4.94	34.20	4.96	35.10	5.01	35.90	5.11
	16	22.70	3.20	27.00	3.92	31.40	4.66	33.40	4.10	33.80	5.03	34.60	5.09	35.40	5.18
	18	22.70	3.26	27.00	4.00	31.40	4.81	32.90	5.14	33.30	5.16	34.10	5.21	35.00	5.26
	20	22.70	3.33	27.00	4.15	31.40	5.18	32.50	5.39	32.90	5.41	33.70	5.46	34.50	5.51
	21	22.70	3.36	27.00	4.30	31.40	5.36	32.20	5.52	32.60	5.54	33.50	5.59	34.30	5.65
	23	22.70	3.59	27.00	4.61	31.40	5.74	31.80	5.76	32.20	5.79	33.00	5.85	33.80	5.90
	25	22.70	3.83	27.00	4.93	30.90	6.00	31.30	6.01	31.70	6.04	32.60	6.10	33.40	6.16
	27	22.70	4.09	27.00	5.27	30.50	6.24	30.90	6.28	31.30	6.31	32.10	6.36	32.90	6.42
	29	22.70	4.37	27.00	5.63	30.00	6.49	30.40	6.53	30.80	6.56	31.60	6.63	32.50	6.68
	31	22.70	4.66	27.00	6.00	29.50	6.75	30.00	6.78	30.40	6.82	31.20	6.89	32.00	6.96
	33	22.70	4.96	27.00	6.40	29.10	7.00	29.50	7.04	29.90	7.07	30.70	7.15	31.50	7.22
35	22.70	5.28	27.00	6.83	28.60	7.26	29.00	7.30	29.50	7.33	30.30	7.41	31.10	7.49	
37	22.70	5.62	27.00	7.28	28.20	7.52	28.60	7.56	29.00	7.60	29.80	7.67	30.60	7.76	
39	22.70	5.98	26.90	7.68	27.70	7.77	28.10	7.82	28.50	7.86	29.40	7.95	30.20	8.02	
41	22.70	6.14	26.68	7.74	27.48	7.83	27.88	7.87	28.28	7.91	29.18	7.97	29.33	8.08	
43	22.70	6.23	26.54	7.79	27.27	7.87	27.67	7.90	28.07	7.94	28.67	7.99	28.88	8.25	
45	22.70	6.30	26.39	7.87	27.00	7.95	27.38	7.98	27.82	8.00	28.09	8.01	28.59	8.42	
48	26.30	6.35	30.32	7.95	30.88	8.02	31.21	8.04	31.88	8.07	32.05	8.04	32.68	8.53	
110%	-5	20.80	2.48	24.80	3.09	28.80	3.69	30.80	3.96	32.80	4.26	35.30	4.42	36.10	4.56
	-2	20.80	2.53	24.80	3.13	28.80	3.72	30.80	4.00	32.80	4.29	35.30	4.47	36.10	4.58
	0	20.80	2.55	24.80	3.15	28.80	3.75	30.80	4.02	32.80	4.34	35.30	4.51	36.10	4.64
	2	20.80	2.61	24.80	3.18	28.80	3.80	30.80	4.07	32.80	4.39	35.30	4.57	36.10	4.70
	4	20.80	2.66	24.80	3.21	28.80	3.84	30.80	4.12	32.80	4.45	35.30	4.64	36.10	4.74

60%	-5	11.30	1.34	13.50	1.56	15.70	1.81	16.80	1.93	17.90	2.09	20.10	2.34	22.30	2.69
	-2	11.30	1.35	13.50	1.58	15.70	1.85	16.80	1.96	17.90	2.11	20.10	2.38	22.30	2.70
	0	11.30	1.37	13.50	1.60	15.70	1.87	16.80	1.98	17.90	2.14	20.10	2.41	22.30	2.74
	2	11.30	1.39	13.50	1.64	15.70	1.90	16.80	2.02	17.90	2.17	20.10	2.46	22.30	2.77
	4	11.30	1.43	13.50	1.67	15.70	1.94	16.80	2.05	17.90	2.20	20.10	2.50	22.30	2.81
	6	11.30	1.45	13.50	1.70	15.70	1.98	16.80	2.09	17.90	2.25	20.10	2.55	22.30	2.88
	8	11.30	1.47	13.50	1.73	15.70	2.02	16.80	2.13	17.90	2.29	20.10	2.60	22.30	2.92
	10	11.30	1.50	13.50	1.77	15.70	2.05	16.80	2.19	17.90	2.34	20.10	2.65	22.30	2.97
	12	11.30	1.53	13.50	1.79	15.70	2.09	16.80	2.23	17.90	2.38	20.10	2.70	22.30	3.02
	14	11.30	1.55	13.50	1.82	15.70	2.11	16.80	2.27	17.90	2.42	20.10	2.75	22.30	3.07
	16	11.30	1.57	13.50	1.85	15.70	2.15	16.80	2.31	17.90	2.46	20.10	2.79	22.30	3.13
	18	11.30	1.60	13.50	1.88	15.70	2.19	16.80	2.35	17.90	2.51	20.10	2.84	22.30	3.19
	20	11.30	1.62	13.50	1.92	15.70	2.23	16.80	2.40	17.90	2.56	20.10	2.90	22.30	3.26
	21	11.30	1.64	13.50	1.93	15.70	2.25	16.80	2.41	17.90	2.58	20.10	2.93	22.30	3.29
	23	11.30	1.66	13.50	1.97	15.70	2.29	16.80	2.46	17.90	2.63	20.10	3.05	22.30	3.50
	25	11.30	1.69	13.50	2.00	15.70	2.38	16.80	2.58	17.90	2.79	20.10	3.25	22.30	3.73
	27	11.30	1.76	13.50	2.12	15.70	2.53	16.80	2.75	17.90	2.98	20.10	3.46	22.30	3.99
	29	11.30	1.85	13.50	2.25	15.70	2.70	16.80	2.93	17.90	3.17	20.10	3.70	22.30	4.26
	31	11.30	1.97	13.50	2.39	15.70	2.86	16.80	3.11	17.90	3.38	20.10	3.93	22.30	4.53
	33	11.30	2.08	13.50	2.53	15.70	3.04	16.80	3.31	17.90	3.59	20.10	4.18	22.30	4.83
35	11.30	2.20	13.50	2.69	15.70	3.22	16.80	3.51	17.90	3.81	20.10	4.45	22.30	5.14	
37	11.30	2.33	13.50	2.84	15.70	3.41	16.80	3.72	17.90	4.04	20.10	4.73	22.30	5.47	
39	11.30	2.45	13.50	3.01	15.70	3.62	16.80	3.95	17.90	4.30	20.10	5.02	22.30	5.82	
41	11.30	2.53	13.50	3.14	15.70	3.75	16.80	4.11	17.90	4.45	20.10	5.26	22.30	6.08	
43	11.30	2.61	13.50	3.27	15.70	3.88	16.80	4.23	17.90	4.61	20.10	5.48	22.30	6.35	
45	11.30	2.73	13.50	3.43	15.70	4.04	16.80	4.39	17.90	4.84	20.10	5.73	22.30	6.70	
48	11.30	2.84	13.50	3.59	15.70	4.18	16.80	4.50	17.90	5.03	20.10	5.94	22.30	7.01	
50%	-5	9.45	1.16	11.30	1.35	13.10	1.55	14.00	1.62	14.90	1.71	16.70	1.94	18.60	2.10
	-2	9.45	1.17	11.30	1.37	13.10	1.56	14.00	1.64	14.90	1.74	16.70	1.97	18.60	2.12
	0	9.45	1.19	11.30	1.40	13.10	1.59	14.00	1.66	14.90	1.76	16.70	2.00	18.60	2.16
	2	9.45	1.21	11.30	1.41	13.10	1.62	14.00	1.69	14.90	1.79	16.70	2.01	18.60	2.20
	4	9.45	1.22	11.30	1.44	13.10	1.64	14.00	1.71	14.90	1.83	16.70	2.06	18.60	2.26
	6	9.45	1.24	11.30	1.46	13.10	1.66	14.00	1.75	14.90	1.86	16.70	2.09	18.60	2.32
	8	9.45	1.27	11.30	1.49	13.10	1.69	14.00	1.79	14.90	1.89	16.70	2.13	18.60	2.40
	10	9.45	1.30	11.30	1.50	13.10	1.72	14.00	1.82	14.90	1.94	16.70	2.18	18.60	2.43
	12	9.45	1.31	11.30	1.52	13.10	1.75	14.00	1.85	14.90	1.98	16.70	2.22	18.60	2.47
	14	9.45	1.33	11.30	1.54	13.10	1.77	14.00	1.89	14.90	2.01	16.70	2.26	18.60	2.52
	16	9.45	1.35	11.30	1.56	13.10	1.79	14.00	1.92	14.90	2.04	16.70	2.30	18.60	2.56
	18	9.45	1.37	11.30	1.59	13.10	1.82	14.00	1.95	14.90	2.08	16.70	2.34	18.60	2.61
	20	9.45	1.39	11.30	1.61	13.10	1.85	14.00	1.98	14.90	2.11	16.70	2.38	18.60	2.66
	21	9.45	1.40	11.30	1.63	13.10	1.87	14.00	2.00	14.90	2.13	16.70	2.41	18.60	2.69
	23	9.45	1.42	11.30	1.65	13.10	1.90	14.00	2.04	14.90	2.17	16.70	2.44	18.60	2.74
	25	9.45	1.44	11.30	1.68	13.10	1.94	14.00	2.08	14.90	2.24	16.70	2.57	18.60	2.93
	27	9.45	1.46	11.30	1.75	13.10	2.05	14.00	2.21	14.90	2.38	16.70	2.74	18.60	3.12
	29	9.45	1.54	11.30	1.84	13.10	2.17	14.00	2.35	14.90	2.53	16.70	2.91	18.60	3.33
	31	9.45	1.63	11.30	1.95	13.10	2.30	14.00	2.49	14.90	2.69	16.70	3.09	18.60	3.54
	33	9.45	1.73	11.30	2.07	13.10	2.44	14.00	2.64	14.90	2.85	16.70	3.29	18.60	3.76
35	9.45	1.82	11.30	2.18	13.10	2.58	14.00	2.79	14.90	3.02	16.70	3.49	18.60	4.00	
37	9.45	1.92	11.30	2.31	13.10	2.74	14.00	2.96	14.90	3.20	16.70	3.71	18.60	4.25	
39	9.45	2.03	11.30	2.43	13.10	2.89	14.00	3.13	14.90	3.39	16.70	3.93	18.60	4.51	
41	9.45	2.11	11.30	2.54	13.10	3.00	14.00	3.28	14.90	3.54	16.70	4.14	18.60	4.72	
43	9.45	2.25	11.30	2.71	13.10	3.10	14.00	3.43	14.90	3.63	16.70	4.35	18.60	4.93	
45	9.45	2.30	11.30	2.78	13.10	3.31	14.00	3.69	14.90	3.79	16.70	4.77	18.60	5.35	
48	9.45	2.36	11.30	2.86	13.10	3.50	14.00	3.93	14.90	3.95	16.70	5.15	18.60	5.76	

10HP heating mode

Combination (Capacity index)	Outdoor air temp.		Indoor temperature(°C DB)											
			16		18		20		21		22		24	
	°C DB	°C WB	kW	PI	kW	PI	kW	PI	kW	PI	kW	PI	kW	PI
130%	-19.8	-20	20.40	5.38	20.30	5.75	20.20	6.14	20.20	6.33	20.10	6.51	20.10	6.90
	-18.8	-19	20.70	5.50	20.60	5.87	20.60	6.25	20.50	6.43	20.50	6.61	20.40	6.99
	-16.7	-17	21.50	5.75	21.40	6.11	21.30	6.47	21.30	6.65	21.30	6.83	21.20	7.19
	-13.7	-15	22.40	6.02	22.30	6.36	22.20	6.71	22.20	6.88	22.10	7.06	22.10	7.40
	-11.8	-13	23.30	6.29	23.30	6.62	23.20	6.95	23.10	7.12	23.10	7.28	23.00	7.61
	-9.8	-11	24.40	6.56	24.30	6.88	24.20	7.20	24.20	7.35	24.20	7.51	24.10	7.83
	-9.5	-10	25.00	6.70	24.90	7.01	24.80	7.31	24.80	7.47	24.70	7.62	24.70	7.93
	-8.5	-9.1	25.50	6.82	25.40	7.12	25.40	7.42	25.30	7.57	25.30	7.72	25.20	8.03
	-7	-7.6	26.40	7.02	26.40	7.31	26.30	7.60	26.30	7.75	26.20	7.89	26.10	8.18
	-5	-5.6	27.80	7.28	27.70	7.56	27.60	7.84	27.60	7.98	27.50	8.10	27.50	8.38
	-3	-3.7	29.10	7.52	29.00	7.79	29.00	8.05	28.90	8.18	28.90	8.31	28.80	8.57
	0	-0.7	31.40	7.89	31.40	8.13	31.30	8.37	31.30	8.46	31.20	8.62	31.20	8.86
	3	2.2	33.90	8.21	33.80	8.44	33.70	8.67	33.70	8.78	33.70	8.90	33.60	9.11
	5	4.1	35.60	8.42	35.50	8.64	35.50	8.85	35.40	8.95	35.40	9.06	35.30	9.27
	7	6	37.40	8.62	37.30	8.82	37.30	9.02	37.20	9.12	37.20	9.22	35.70	8.86
	9	7.9	39.30	8.80	39.20	8.99	39.20	9.18	39.10	9.28	38.30	9.08	35.70	8.32
11	9.8	41.30	8.97	41.20	9.15	41.00	9.27	39.60	8.90	38.30	8.54	35.70	7.84	
13	11.8	43.50	9.14	43.40	9.32	41.00	8.69	39.60	8.34	38.30	8.02	35.70	7.35	
15	13.7	45.60	9.30	43.60	8.83	41.00	8.18	39.60	7.87	38.30	7.55	35.70	6.94	
120%	-19.8	-20	20.30	5.89	20.20	6.24	20.10	6.59	20.10	6.76	20.10	6.94	20.00	7.29
	-18.8	-19	20.60	6.00	20.50	6.35	20.50	6.69	20.40	6.86	20.40	7.04	20.30	7.38
	-16.7	-17	21.40	6.24	21.30	6.57	21.17	6.90	21.20	7.07	21.20	7.23	21.10	7.56
	-13.7	-15	22.30	6.48	22.20	6.80	22.10	7.12	22.10	7.28	22.10	7.44	22.00	7.76
	-11.8	-13	23.20	6.73	23.20	7.04	23.10	7.34	23.10	7.50	23.00	7.65	23.00	7.96
	-9.8	-11	24.30	6.99	24.20	7.27	24.20	7.57	24.10	7.72	24.10	7.86	24.00	8.15
	-9.5	-10	24.90	7.12	24.80	7.40	24.70	7.68	24.70	7.83	24.70	7.97	24.60	8.25
	-8.5	-9.1	25.40	7.22	25.30	7.50	25.30	7.78	25.20	7.92	25.20	8.07	25.10	8.34
	-7	-7.6	26.30	7.41	26.30	7.68	26.20	7.95	26.20	8.08	26.10	8.21	26.10	8.48
	-5	-5.6	27.70	7.65	27.60	7.91	27.50	8.16	27.50	8.29	27.50	8.42	27.40	8.67
	-3	-3.7	29.00	7.88	29.00	8.12	28.90	8.36	28.90	8.48	28.80	8.61	28.80	8.85
	0	-0.7	31.30	8.21	31.30	8.44	31.20	8.66	31.20	8.78	31.10	8.88	31.10	9.11
	3	2.2	33.80	8.52	33.70	8.73	33.70	8.93	33.60	9.04	33.60	9.14	32.90	9.09
	5	4.1	35.50	8.71	35.40	8.91	35.40	9.10	35.30	9.20	35.30	9.30	32.90	8.54
	7	6	37.30	8.88	37.30	9.07	37.20	9.26	36.60	9.13	35.40	8.76	32.90	8.04
	9	7.9	39.20	9.06	39.10	9.24	37.80	8.93	36.60	8.58	35.40	8.23	32.90	7.56
11	9.8	41.20	9.22	40.20	9.06	37.80	8.40	36.60	8.07	35.40	7.75	32.90	7.13	
13	11.8	42.70	9.13	40.20	8.50	37.80	7.88	36.60	7.58	35.40	7.28	32.90	6.70	
15	13.7	42.70	8.60	40.20	8.01	37.80	7.43	36.60	7.15	35.40	6.87	32.90	6.32	
110%	-19.8	-20	20.20	6.40	20.10	6.72	20.00	7.05	20.00	7.21	20.01	7.36	19.90	7.69
	-18.8	-19	20.50	6.50	20.40	6.82	20.40	7.14	20.40	7.29	20.30	7.45	20.30	7.77
	-16.7	-17	21.30	6.72	21.20	7.03	21.50	7.33	21.10	7.48	21.10	7.64	21.00	7.94
	-13.7	-15	22.20	6.95	22.10	7.24	22.00	7.53	22.00	7.68	22.00	7.83	21.90	8.11
	-11.8	-13	23.10	7.18	23.10	7.46	23.00	7.74	23.00	7.88	22.90	8.02	22.90	8.30
	-9.8	-11	24.20	7.41	24.10	7.68	24.10	7.95	24.00	8.08	24.00	8.21	24.00	8.48
	-9.5	-10	24.80	7.53	24.70	7.79	24.60	8.06	24.60	8.18	24.60	8.31	24.50	8.57
	-8.5	-9.1	25.30	7.63	25.20	7.89	25.20	8.14	25.10	8.27	25.10	8.40	25.10	7.66
	-7	-7.6	26.20	7.81	26.20	8.04	26.10	8.29	26.10	8.42	26.10	8.54	26.00	8.79
	-5	-5.6	27.60	8.03	27.50	8.26	27.40	8.49	27.40	8.61	27.40	8.73	27.30	8.97
	-3	-3.7	28.90	8.23	28.90	8.45	28.80	8.68	28.80	8.79	28.70	8.90	28.70	9.12
	0	-0.7	31.20	8.54	31.20	8.75	31.10	8.95	31.10	9.05	31.10	9.16	30.20	8.98
	3	2.2	33.70	8.83	33.60	9.01	33.60	9.20	33.50	9.29	32.40	8.91	30.20	8.17
	5	4.1	35.40	8.99	35.40	9.18	34.70	9.09	33.50	8.73	32.40	8.38	30.20	7.69
	7	6	37.20	9.16	36.90	9.22	34.70	8.54	33.50	8.20	32.40	7.88	30.20	7.23
	9	7.9	39.10	9.31	36.90	8.67	34.70	8.03	33.50	7.72	32.40	7.41	30.20	6.82
11	9.8	39.10	8.76	36.90	8.15	34.70	7.56	33.50	7.27	32.40	6.99	30.20	6.43	
13	11.8	39.10	8.21	36.90	7.65	34.70	7.11	33.50	6.84	32.40	6.57	30.20	6.06	
15	13.7	39.10	7.29	36.90	7.21	34.70	6.71	33.50	6.45	32.40	6.22	30.20	5.73	
100%	-19.8	-20	20.10	6.92	20.00	7.21	20.00	7.50	19.90	7.65	19.90	7.79	19.80	8.08
	-18.8	-19	20.40	7.01	20.40	7.29	20.30	7.58	20.30	7.73	20.20	7.88	20.20	8.16

	-16.7	-17	21.20	7.21	21.10	7.48	21.10	7.76	21.00	7.90	21.00	8.03	21.00	8.31
	-13.7	-15	22.10	7.41	22.00	7.68	21.90	7.95	21.90	8.08	21.90	8.21	21.80	8.48
	-11.8	-13	23.00	7.63	23.00	7.88	22.90	8.13	22.90	8.26	22.90	8.39	22.80	8.65
	-9.8	-11	24.10	7.84	24.00	8.08	24.00	8.32	24.00	8.45	23.90	8.57	23.90	8.81
	-9.5	-10	24.70	7.95	24.60	8.18	24.60	8.42	24.50	8.54	24.50	8.66	24.40	8.89
	-8.5	-9.1	25.20	8.03	25.10	8.27	25.10	8.50	25.10	8.62	25.00	8.74	25.00	8.96
	-7	-7.6	26.10	8.19	26.10	8.42	26.00	8.64	26.00	8.76	26.00	8.86	25.90	9.09
	-5	-5.6	27.50	8.40	27.40	8.61	27.40	8.83	27.30	8.92	27.30	9.03	27.20	9.25
	-3	-3.7	28.80	8.59	28.80	7.80	28.70	8.99	28.70	9.09	28.70	9.19	27.50	8.81
	0	-0.7	31.10	8.86	31.10	9.05	31.00	9.24	30.50	9.09	29.50	8.72	27.50	8.00
	3	2.2	33.60	9.12	33.50	9.29	31.50	8.60	30.50	8.26	29.50	7.94	27.50	7.28
	5	4.1	35.30	9.29	33.50	8.73	31.50	8.08	30.50	7.78	29.50	7.47	27.50	6.87
	7	6	35.50	8.82	33.50	8.20	31.50	7.61	30.50	7.32	29.50	7.04	27.50	6.47
	9	7.9	35.50	8.28	33.50	7.72	31.50	7.17	30.50	6.81	29.50	6.63	27.50	6.11
	11	9.8	35.50	7.80	33.50	7.27	31.50	6.76	30.50	6.50	29.50	6.26	27.50	5.77
	13	11.8	35.50	7.32	33.50	6.84	31.50	6.37	30.50	6.13	29.50	5.90	27.50	5.45
	15	13.7	35.50	6.91	33.50	6.45	31.50	6.01	30.50	5.79	29.50	5.57	27.50	5.16
90%	-19.8	-20	19.96	7.43	19.86	7.69	19.86	7.96	19.77	8.08	19.77	8.22	19.77	8.48
	-18.8	-19	20.26	7.51	20.26	7.78	20.17	8.03	20.17	8.16	20.17	8.29	20.06	8.55
	-16.7	-17	21.06	7.70	20.96	7.95	20.96	8.19	20.96	8.32	20.86	8.44	20.86	8.69
	-13.7	-15	21.96	7.89	21.86	8.12	21.86	8.36	21.76	8.48	21.76	8.60	21.76	8.84
	-11.8	-13	22.86	8.07	22.86	8.30	22.76	8.53	22.76	8.65	22.76	8.76	22.66	8.98
	-9.8	-11	23.96	8.26	23.96	8.48	23.86	8.70	23.86	8.81	23.86	8.92	23.76	9.14
	-9.5	-10	24.56	8.36	24.46	8.58	24.46	8.79	24.36	8.89	24.36	9.00	24.36	9.21
	-8.5	-9.1	25.06	8.45	25.06	8.66	24.96	8.86	24.96	8.96	24.96	9.07	24.66	9.16
	-7	-7.6	25.95	8.59	25.95	8.79	25.86	8.99	25.86	9.09	25.86	9.19	24.66	8.75
	-5	-5.6	27.35	8.78	27.25	8.96	27.25	9.15	27.15	9.25	26.45	8.96	24.66	8.22
	-3	-3.7	28.65	8.94	28.65	9.12	28.35	9.16	27.35	8.80	26.45	8.44	24.66	7.75
	0	-0.7	31.05	9.20	30.15	8.97	28.35	8.31	27.35	7.99	26.45	7.67	24.66	7.05
	3	2.2	31.94	8.77	30.15	8.16	28.35	7.57	27.35	7.28	26.45	7.00	24.66	6.44
	5	4.1	31.94	8.24	30.15	7.68	28.35	7.14	27.35	6.86	26.45	6.60	24.66	6.08
	7	6	31.94	7.75	30.15	7.23	28.35	6.72	27.35	6.47	26.45	6.23	24.66	5.74
9	7.9	31.94	7.30	30.15	6.81	28.35	6.33	27.35	6.11	26.45	5.88	24.66	5.43	
11	9.8	31.94	6.88	30.15	6.42	28.35	5.99	27.35	5.77	26.45	5.55	24.66	5.14	
13	11.8	31.94	6.47	30.15	6.06	28.35	5.64	27.35	5.45	26.45	5.25	24.66	4.85	
15	13.7	31.94	6.12	30.15	5.72	28.35	5.35	27.35	5.16	26.45	4.97	24.66	4.61	
80%	-19.8	-20	19.90	7.95	19.80	8.17	19.80	8.41	19.80	8.53	19.70	8.65	19.70	8.87
	-18.8	-19	20.20	8.01	20.20	8.25	20.10	8.48	20.10	8.60	20.10	8.71	20.00	8.94
	-16.7	-17	21.00	8.18	20.90	8.40	20.90	8.63	20.90	8.74	20.90	8.84	20.80	9.06
	-13.7	-15	21.90	8.35	21.80	8.56	21.80	8.78	21.80	8.87	21.70	8.98	21.70	9.20
	-11.8	-13	22.80	8.52	22.80	8.73	22.70	8.92	22.70	9.02	22.70	9.13	22.00	8.88
	-9.8	-11	23.90	8.69	23.90	8.88	23.80	9.08	23.80	9.17	23.60	9.15	22.00	8.39
	-9.5	-10	24.50	8.78	24.40	8.96	24.40	9.15	24.40	9.25	23.60	8.88	22.00	8.14
	-8.5	-9.1	25.00	8.85	23.24	9.04	24.90	9.22	24.40	9.01	23.60	8.65	22.00	7.93
	-7	-7.6	25.90	8.98	25.90	9.16	25.20	8.96	24.40	8.61	23.60	8.26	22.00	7.58
	-5	-5.6	27.30	9.14	26.80	9.09	25.20	8.42	24.40	8.09	23.60	7.77	22.00	7.14
	-3	-3.7	28.40	9.19	26.80	8.56	25.20	7.93	24.40	7.63	23.60	7.32	22.00	6.74
	0	-0.7	28.40	8.34	26.80	7.77	25.20	7.21	24.40	6.95	23.60	6.67	22.00	6.15
	3	2.2	28.40	7.60	26.80	7.09	25.20	6.59	24.40	6.34	23.60	6.11	22.00	5.63
	5	4.1	28.40	7.16	26.80	6.68	25.20	6.22	24.40	5.99	23.60	5.77	22.00	5.33
	7	6	28.40	6.74	26.80	6.31	25.20	5.87	24.40	5.66	23.60	5.46	22.00	5.04
9	7.9	28.40	6.36	26.80	5.95	25.20	5.54	24.40	5.35	23.60	5.16	22.00	4.77	
11	9.8	28.40	6.01	26.80	5.62	25.20	5.25	24.40	5.06	23.60	4.88	22.00	4.53	
13	11.8	28.40	5.66	26.80	5.31	25.20	4.96	24.40	4.78	23.60	4.62	22.00	4.28	
15	13.7	28.40	5.36	26.80	5.03	25.20	4.70	24.40	4.54	23.60	4.38	22.00	4.07	
70%	-19.8	-20	19.75	8.46	19.66	8.66	19.66	8.86	19.66	8.96	19.66	9.07	19.16	8.97
	-18.8	-19	20.05	8.53	20.05	8.73	19.96	8.92	19.96	9.02	19.96	9.13	19.16	8.79
	-16.7	-17	20.85	8.67	20.85	8.86	20.75	9.05	20.75	9.15	20.55	8.15	19.16	8.38
	-13.7	-15	21.75	8.82	21.65	9.00	21.65	9.19	21.25	9.05	20.55	8.69	19.16	7.97
	-11.8	-13	22.65	8.96	22.65	9.14	22.05	8.92	21.25	8.58	20.55	8.23	19.16	7.55
	-9.8	-11	23.75	9.11	23.45	9.10	22.05	8.43	21.25	8.10	20.55	7.78	19.16	7.15
	-9.5	-10	24.35	9.19	23.45	8.84	22.05	8.18	21.25	7.87	20.55	7.56	19.16	6.95
	-8.5	-9.1	24.84	9.24	23.45	8.60	22.05	7.97	21.25	7.66	20.55	7.36	19.16	6.77
	-7	-7.6	24.84	8.82	23.45	8.21	22.05	7.62	21.25	7.33	20.55	7.05	19.16	6.48
-5	-5.6	24.84	8.29	23.45	7.73	22.05	7.17	21.25	6.90	20.55	6.85	19.16	6.12	

	-3	-3.7	24.84	7.81	23.45	7.28	22.05	6.77	21.25	6.51	20.55	6.27	19.16	5.78
	0	-0.7	24.84	7.11	23.45	6.64	22.05	6.18	21.25	5.95	20.55	5.73	19.16	5.30
	3	2.2	24.84	6.49	23.45	6.08	22.05	5.66	21.25	5.46	20.55	5.26	19.16	4.86
	5	4.1	24.84	6.13	23.45	5.73	22.05	5.36	21.25	5.16	20.55	4.97	19.16	4.61
	7	6	24.84	5.79	23.45	5.43	22.05	5.06	21.25	4.88	20.55	4.71	19.16	4.37
	9	7.9	24.84	5.47	23.45	5.13	22.05	4.79	21.25	4.63	20.55	4.47	19.16	4.14
	11	9.8	24.84	5.18	23.45	4.85	22.05	4.55	21.25	4.39	20.55	4.24	19.16	3.93
	13	11.8	24.84	4.89	23.45	4.60	22.05	4.30	21.25	4.16	20.55	4.01	19.16	3.74
	15	13.7	24.84	4.63	23.45	4.36	22.05	4.08	21.25	3.95	20.55	3.81	19.16	3.56
60%	-19.8	-20	19.70	8.97	19.60	9.14	18.90	8.80	18.30	8.45	17.70	8.11	16.50	7.44
	-18.8	-19	20.00	9.03	20.00	9.20	18.90	8.61	18.30	8.27	17.70	7.94	16.50	7.28
	-16.7	-17	20.80	9.15	20.10	8.86	18.90	8.21	18.30	7.90	17.70	7.58	16.50	6.97
	-13.7	-15	21.30	9.05	20.10	8.42	18.90	7.81	18.30	7.51	17.70	7.21	16.50	6.63
	-11.8	-13	21.30	8.57	20.10	7.97	18.90	7.40	18.30	7.13	17.70	6.85	16.50	6.33
	-9.8	-11	21.30	8.09	20.10	7.54	18.90	7.01	18.30	6.74	17.70	6.48	16.50	5.98
	-9.5	-10	21.30	7.87	20.10	7.33	18.90	6.81	18.30	6.56	17.70	6.30	16.50	5.81
	-8.5	-9.1	21.30	7.66	20.10	7.15	18.90	6.64	18.30	6.39	17.70	6.15	16.50	5.67
	-7	-7.6	21.30	7.32	20.10	6.84	18.90	6.35	18.30	6.13	17.70	5.89	16.50	5.45
	-5	-5.6	21.30	6.90	20.10	6.44	18.90	6.00	18.30	5.78	17.70	5.56	16.50	5.15
	-3	-3.7	21.30	6.51	20.10	6.09	18.90	5.67	18.30	5.47	17.70	5.27	16.50	4.87
	0	-0.7	21.30	5.95	20.10	5.57	18.90	5.20	18.30	5.02	17.70	4.83	16.50	4.48
	3	2.2	21.30	5.46	20.10	5.12	18.90	4.78	18.30	4.61	17.70	4.46	16.50	4.13
	5	4.1	21.30	5.16	20.10	4.84	18.90	4.53	18.30	4.38	17.70	4.22	16.50	3.92
	7	6	21.30	4.88	20.10	4.59	18.90	4.29	18.30	4.15	17.70	4.01	16.50	3.73
9	7.9	21.30	4.62	20.10	4.35	18.90	4.07	18.30	3.94	17.70	3.80	16.50	3.55	
11	9.8	21.30	4.39	20.10	4.13	18.90	3.87	18.30	3.75	17.70	3.62	16.50	3.38	
13	11.8	21.30	4.15	20.10	3.91	18.90	3.68	18.30	3.56	17.70	3.44	16.50	3.21	
15	13.7	21.30	3.95	20.10	3.72	18.90	3.50	18.30	3.39	17.70	3.28	16.50	3.06	
50%	-19.8	-20	17.74	8.16	16.75	7.60	15.75	7.06	15.15	6.80	14.65	6.53	13.66	6.02
	-18.8	-19	17.74	7.98	16.75	7.44	15.75	6.92	15.15	6.65	14.65	6.39	13.66	5.90
	-16.7	-17	17.74	7.62	16.75	7.11	15.75	6.61	15.15	6.36	14.65	6.13	13.66	5.65
	-13.7	-15	17.74	7.25	16.75	6.77	15.75	6.29	15.15	6.07	14.65	5.84	13.66	5.40
	-11.8	-13	17.74	6.89	16.75	6.43	15.75	5.99	15.15	5.77	14.65	5.55	13.66	5.14
	-9.8	-11	17.74	6.52	16.75	6.10	15.75	5.68	15.15	5.47	14.65	5.28	13.66	4.88
	-9.5	-10	17.74	6.34	16.75	5.93	15.75	5.53	15.15	5.34	14.65	5.14	13.66	4.75
	-8.5	-9.1	17.74	6.19	16.75	5.79	15.75	5.40	15.15	5.21	14.65	5.02	13.66	4.64
	-7	-7.6	17.74	5.93	16.75	5.55	15.75	5.18	15.15	5.00	14.65	4.82	13.66	4.47
	-5	-5.6	17.74	5.59	16.75	5.25	15.75	4.90	15.15	4.73	14.65	4.57	13.66	4.23
	-3	-3.7	17.74	5.30	16.75	4.97	15.75	4.64	15.15	4.49	14.65	4.33	13.66	4.02
	0	-0.7	17.74	4.86	16.75	4.57	15.75	4.28	15.15	4.13	14.65	3.99	13.66	3.72
	3	2.2	17.74	4.48	16.75	4.21	15.75	3.94	15.15	3.81	14.65	3.69	13.66	3.44
	5	4.1	17.74	4.25	16.75	3.99	15.75	3.75	15.15	3.63	14.65	3.51	13.66	3.27
	7	6	17.74	4.03	16.75	3.79	15.75	3.57	15.15	3.45	14.65	3.34	13.66	3.12
9	7.9	17.74	3.82	16.75	3.61	15.75	3.39	15.15	3.29	14.65	3.18	13.66	2.97	
11	9.8	17.74	3.64	16.75	3.43	15.75	3.23	15.15	3.13	14.65	3.03	13.66	2.84	
13	11.8	17.74	3.46	16.75	3.26	15.75	3.07	15.15	2.98	14.65	2.89	13.66	2.71	
15	13.7	17.74	3.29	16.75	3.11	15.75	2.94	15.15	2.85	14.65	2.76	13.66	2.59	

Note:

1. [] is shown as reference.
2. The above table shows the average value of conditions may operate.
3. It is recommended to connect less than 130%.

12HP cooling mode

Combination (%) (Capacity index)	Outdoor temperature (°C DB)	Indoor temperature(°C DB/WD)													
		DB:20.8,WB:14		DB:23.3,WB:16		DB:25.8,WB:18		DB:27,WB:19		DB:28.2,WB:20		DB:30.7,WB:22		DB:32,WB:24	
		TC	PI	TC	PI	TC	PI	TC	PI	TC	PI	TC	PI	TC	PI
130%	-5	29.43	3.70	35.05	4.52	40.68	4.84	42.23	5.04	44.26	5.18	45.34	5.64	46.48	5.67
	-2	29.43	3.70	35.05	4.61	40.68	4.84	42.23	5.07	44.26	5.18	45.34	5.71	46.48	5.73
	0	29.43	3.76	35.05	4.68	40.68	5.02	42.23	5.35	44.26	5.48	45.34	5.78	46.48	5.80
	2	29.43	3.83	35.05	4.69	40.68	5.19	42.23	5.65	44.26	5.55	45.34	5.82	46.48	5.89
	4	29.43	3.92	35.05	4.79	40.68	5.37	42.23	5.67	44.26	5.62	45.34	5.82	46.48	6.00
	6	29.43	3.99	35.05	4.88	40.68	5.57	42.23	5.72	43.77	5.79	44.79	5.81	45.97	6.05
	8	29.43	4.09	35.05	4.99	40.68	5.85	42.23	6.00	43.23	5.98	44.30	3.90	45.39	6.11
	10	29.43	4.17	35.05	5.10	40.68	6.06	42.23	6.20	42.71	4.04	43.79	4.06	44.86	6.28
	12	29.43	4.25	35.05	5.20	40.68	6.19	41.63	4.03	42.23	4.06	43.19	4.07	44.27	6.32
	14	29.43	4.33	35.05	5.30	40.56	4.05	41.16	4.06	41.63	4.08	42.71	4.09	43.79	6.46
	16	29.43	4.41	35.05	5.41	40.08	4.06	40.56	4.08	41.04	4.10	42.11	4.12	43.19	6.57
	18	29.43	4.49	35.05	5.52	39.48	6.47	39.96	6.50	40.56	6.54	41.63	6.60	42.71	6.66
	20	29.43	4.59	35.05	5.87	38.88	6.79	39.48	6.82	39.96	6.86	41.04	6.92	42.11	6.99
	21	29.43	4.71	35.05	6.08	38.64	6.94	39.24	6.98	39.72	7.02	40.80	7.09	41.87	7.15
	23	29.43	5.05	35.05	6.52	38.16	7.26	38.64	7.30	39.12	7.33	40.20	7.41	41.27	7.48
	25	29.43	5.39	35.05	6.98	37.57	7.58	38.04	7.61	38.64	7.66	39.72	7.74	40.80	7.81
	27	29.43	5.76	35.05	7.47	37.09	7.90	37.57	7.94	38.04	7.98	39.12	8.07	40.20	8.15
	29	29.43	6.15	35.05	7.98	36.49	8.21	36.97	8.26	37.57	8.31	38.64	8.40	39.72	8.48
	31	29.43	6.57	34.94	8.44	35.89	8.54	36.49	8.59	36.97	8.63	38.04	8.73	39.12	8.82
	33	29.43	6.99	34.33	8.76	35.41	8.86	35.89	8.91	36.49	8.96	37.57	9.05	38.52	9.15
	35	29.43	7.46	33.74	9.08	34.81	9.19	35.41	9.24	35.89	9.29	36.97	9.40	38.04	9.49
37	29.43	7.93	33.26	9.41	34.34	9.52	34.81	9.57	35.41	9.63	36.37	9.74	37.45	9.85	
39	29.43	8.44	32.66	9.51	33.74	9.84	34.34	9.90	34.81	9.96	35.89	10.07	36.97	10.19	
41	29.43	8.89	32.32	9.60	33.38	9.93	33.98	9.99	34.46	10.05	35.54	10.09	35.55	10.28	
43	29.43	9.11	32.09	9.65	33.21	9.96	33.81	10.04	34.11	10.06	34.89	10.11	35.13	10.30	
45	29.43	9.57	31.89	9.74	32.85	10.05	33.45	10.10	33.61	10.11	33.94	10.14	34.44	10.50	
48	29.43	9.91	33.02	10.05	35.82	10.14	36.48	10.19	36.77	10.23	36.61	10.32	37.28	10.34	
120%	-5	27.16	3.58	32.30	4.33	37.57	5.12	40.20	5.58	42.11	5.82	43.07	6.01	44.03	6.17
	-2	27.16	3.61	32.30	4.38	37.57	5.17	40.20	5.62	42.11	5.89	43.07	6.06	44.03	6.19
	0	27.16	3.64	32.30	4.40	37.57	5.23	40.20	5.63	42.11	5.94	43.07	6.09	44.03	6.20
	2	27.16	3.65	32.30	4.45	37.57	5.27	40.20	5.68	42.11	5.96	43.07	6.14	44.03	6.21
	4	27.16	3.69	32.30	4.51	37.57	5.34	40.20	5.74	42.11	6.04	43.07	6.15	44.03	6.23
	6	27.16	3.73	32.30	4.54	37.57	5.40	40.20	5.80	42.11	6.11	43.07	6.20	44.03	6.25
	8	27.16	3.76	32.30	4.59	37.57	5.48	40.20	5.87	42.11	6.17	43.07	6.22	44.03	6.28
	10	27.16	3.81	32.30	4.65	37.57	5.53	40.20	5.98	42.11	6.18	43.07	6.24	44.03	6.31
	12	27.16	3.88	32.30	4.73	37.57	5.64	40.20	6.09	41.52	6.20	42.47	6.20	43.43	6.35
	14	27.16	3.95	32.30	4.83	37.57	5.75	40.20	6.21	40.92	6.24	41.99	6.30	42.95	6.42
	16	27.16	4.03	32.30	4.93	37.57	5.86	39.96	4.10	40.44	6.33	41.40	6.41	42.35	6.52
	18	27.16	4.10	32.30	5.03	37.57	6.05	39.36	6.47	39.84	6.49	40.80	6.55	41.87	6.61
	20	27.16	4.19	32.30	5.22	37.57	6.52	38.88	6.78	39.36	6.81	40.32	6.87	41.28	6.93
	21	27.16	4.22	32.30	5.41	37.57	6.75	38.52	6.94	39.00	6.97	40.08	7.03	41.04	7.10
	23	27.16	4.51	32.30	5.80	37.57	7.22	38.05	7.25	38.52	7.29	39.48	7.36	40.44	7.42
	25	27.16	4.82	32.30	6.20	36.97	7.54	37.45	7.57	37.93	7.60	39.00	7.67	39.96	7.75
	27	27.16	5.15	32.30	6.63	36.49	7.85	36.97	7.90	37.45	7.93	38.40	8.00	39.36	8.08
	29	27.16	5.49	32.30	7.08	35.89	8.16	36.37	8.21	36.85	8.25	37.81	8.33	38.88	8.41
	31	27.16	5.86	32.30	7.55	35.29	8.49	35.89	8.53	36.37	8.58	37.33	8.66	38.28	8.75
	33	27.16	6.24	32.30	8.05	34.81	8.81	35.29	8.86	35.77	8.90	36.73	8.99	37.69	9.08
	35	27.16	6.64	32.30	8.59	34.22	9.13	34.70	9.18	35.29	9.22	36.25	9.32	37.21	9.42
37	27.16	7.06	32.30	9.15	33.74	9.46	34.22	9.51	34.70	9.55	35.65	9.65	36.61	9.76	
39	27.16	7.52	32.18	9.66	33.14	9.77	33.62	9.84	34.10	9.88	35.17	9.99	36.13	10.09	
41	27.16	7.72	31.92	9.73	32.88	9.84	33.36	9.90	33.84	9.95	34.91	10.02	35.09	10.17	
43	27.16	7.84	31.75	9.80	32.62	9.90	33.10	9.94	33.58	9.99	34.31	10.05	34.55	10.37	
45	27.16	7.93	31.58	9.89	32.31	9.99	32.75	10.04	33.28	10.07	33.61	10.08	34.20	10.60	
48	31.47	7.99	36.28	10.00	36.95	10.08	37.34	10.11	38.14	10.15	38.34	10.12	39.10	10.73	
110%	-5	24.89	3.12	29.67	3.89	34.46	4.64	36.85	4.98	39.24	5.36	42.24	5.56	43.19	5.73
	-2	24.89	3.18	29.67	3.94	34.46	4.68	36.85	5.03	39.24	5.40	42.24	5.62	43.19	5.76
	0	24.89	3.21	29.67	3.96	34.46	4.71	36.85	5.06	39.24	5.46	42.24	5.67	43.19	5.83
	2	24.89	3.28	29.67	4.00	34.46	4.79	36.85	5.11	39.24	5.52	42.24	5.75	43.19	5.91
	4	24.89	3.35	29.67	4.04	34.46	4.83	36.85	5.18	39.24	5.60	42.24	5.83	43.19	5.96

	6	24.89	3.38	29.67	4.09	34.46	4.88	36.85	5.26	39.24	5.66	42.24	5.90	43.19	6.05
	8	24.89	3.41	29.67	4.15	34.46	4.93	36.85	5.31	39.24	5.73	42.24	5.94	43.19	6.12
	10	24.89	3.45	29.67	4.21	34.46	5.00	36.85	5.41	39.24	5.82	42.24	5.98	43.19	6.17
	12	24.89	3.53	29.67	4.30	34.46	5.10	36.85	5.52	39.24	5.93	41.76	6.06	42.59	6.25
	14	24.89	3.59	29.67	4.37	34.46	5.20	36.85	5.61	39.24	6.04	41.16	6.11	42.12	6.29
	16	24.89	3.65	29.67	4.45	34.46	5.30	36.85	5.72	39.24	6.16	40.68	6.19	41.52	6.36
	18	24.89	3.72	29.67	4.54	34.46	5.41	36.85	5.88	39.24	6.46	40.08	6.50	41.04	6.57
	20	24.89	3.79	29.67	4.64	34.46	5.72	36.85	6.32	38.65	6.77	39.60	6.82	40.44	6.88
	21	24.89	3.83	29.67	4.77	34.46	5.93	36.85	6.55	38.41	6.93	39.25	6.98	40.20	7.04
	23	24.89	4.01	29.67	5.11	34.46	6.36	36.85	7.03	37.81	7.24	38.77	7.31	39.60	7.37
	25	24.89	4.28	29.67	5.47	34.46	6.80	36.85	7.53	37.33	7.55	38.17	7.63	39.12	7.69
	27	24.89	4.56	29.67	5.84	34.46	7.27	36.25	7.85	36.73	7.87	37.69	7.94	38.53	8.02
	29	24.89	4.87	29.67	6.24	34.46	7.77	35.77	8.16	36.25	8.20	37.09	8.27	38.05	8.35
	31	24.89	5.19	29.67	6.65	34.46	8.30	35.18	8.48	35.65	8.52	36.61	8.59	37.45	8.68
	33	24.89	5.52	29.67	7.09	34.22	8.75	34.70	8.80	35.18	8.83	36.01	8.92	36.97	9.01
	35	24.89	5.87	29.67	7.55	33.62	9.07	34.10	9.12	34.58	9.16	35.42	9.25	36.37	9.34
	37	24.89	6.25	29.67	8.04	33.14	9.40	33.62	9.43	33.98	9.48	34.94	9.58	35.77	9.66
	39	24.89	6.64	29.67	8.57	32.54	9.71	33.02	9.76	33.50	9.81	34.34	9.91	35.30	10.01
	41	24.89	6.71	29.67	8.64	32.29	9.78	32.77	9.83	33.25	9.88	33.90	9.98	34.23	10.07
	43	24.89	6.77	29.67	8.75	32.03	9.85	32.51	9.90	32.99	9.95	33.60	10.01	33.71	10.28
	45	24.89	6.99	29.67	8.79	31.71	9.94	32.17	10.02	32.70	10.04	33.26	10.29	33.39	10.52
	48	27.25	7.24	32.50	9.54	34.22	10.01	34.67	10.09	35.40	10.14	35.82	10.33	36.10	10.63
100%	-5	22.61	2.84	26.92	3.42	31.35	4.07	33.50	4.36	35.65	4.74	40.08	5.40	42.35	5.63
	-2	22.61	2.88	26.92	3.47	31.35	4.12	33.50	4.45	35.65	4.80	40.08	5.46	42.35	5.67
	0	22.61	2.91	26.92	3.50	31.35	4.16	33.50	4.50	35.65	4.84	40.08	5.55	42.35	5.73
	2	22.61	2.96	26.92	3.55	31.35	4.21	33.50	4.56	35.65	4.90	40.08	5.63	42.35	5.82
	4	22.61	2.99	26.92	3.59	31.35	4.27	33.50	4.63	35.65	4.96	40.08	5.69	42.35	5.89
	6	22.61	3.03	26.92	3.66	31.35	4.33	33.50	4.71	35.65	5.03	40.08	5.77	42.35	5.98
	8	22.61	3.09	26.92	3.71	31.35	4.41	33.50	4.76	35.65	5.12	40.08	5.86	42.35	6.08
	10	22.61	3.12	26.92	3.78	31.35	4.48	33.50	4.84	35.65	5.21	40.08	5.95	42.35	6.16
	12	22.61	3.17	26.92	3.86	31.35	4.56	33.50	4.93	35.65	5.31	40.08	6.06	41.75	6.21
	14	22.61	3.23	26.92	3.93	31.35	4.65	33.50	5.03	35.65	5.41	40.08	6.19	41.28	6.29
	16	22.61	3.29	26.92	4.00	31.35	4.75	33.50	5.12	35.65	5.52	39.84	6.26	40.68	6.36
	18	22.61	3.36	26.92	4.08	31.35	4.83	33.50	5.22	35.65	5.63	39.36	6.47	40.20	6.52
	20	22.61	3.42	26.92	4.16	31.35	4.98	33.50	5.49	35.65	6.03	38.76	6.77	39.60	6.83
	21	22.61	3.45	26.92	4.20	31.35	5.16	33.50	5.69	35.65	6.24	38.53	6.93	39.36	6.99
	23	22.61	3.54	26.92	4.48	31.35	5.53	33.50	6.09	35.65	6.69	38.05	7.25	38.76	7.31
	25	22.61	3.77	26.92	4.78	31.35	5.92	33.50	6.53	35.65	7.16	37.45	7.57	38.28	7.63
	27	22.61	4.03	26.92	5.10	31.35	6.32	33.50	6.98	35.65	7.66	36.85	7.88	37.69	7.96
	29	22.61	4.28	26.92	5.44	31.35	6.75	33.50	7.46	35.53	8.14	36.37	8.21	37.21	8.27
	31	22.61	4.56	26.92	5.81	31.35	7.20	33.50	7.96	35.05	8.46	35.77	8.53	36.61	8.60
	33	22.61	4.84	26.92	6.19	31.35	7.68	33.50	8.49	34.46	8.77	35.30	8.85	36.13	8.93
	35	22.61	5.15	26.92	6.58	31.35	8.19	33.50	9.05	33.86	9.09	34.70	9.18	35.53	9.25
	37	22.61	5.48	26.92	7.00	31.35	8.72	32.90	9.37	33.38	9.42	34.22	9.50	34.94	9.58
	39	22.61	5.82	26.92	7.44	31.35	9.29	32.42	9.69	32.78	9.74	33.62	9.82	34.46	9.92
	41	22.61	6.09	26.92	7.71	31.35	9.63	31.92	9.76	32.53	9.89	33.04	10.05	33.96	10.12
	43	22.61	6.36	26.92	7.99	31.35	9.80	31.42	9.87	32.29	9.98	33.23	10.12	33.36	10.24
	45	22.61	6.73	26.92	8.35	31.35	9.97	30.75	10.01	32.13	10.16	32.95	10.28	32.69	10.37
	48	23.42	7.02	27.88	8.64	32.47	9.99	30.53	10.12	33.22	10.34	32.05	10.38	33.11	10.47
90%	-5	20.34	2.51	24.29	3.02	28.24	3.56	30.15	3.88	32.06	4.13	36.01	4.75	39.96	5.44
	-2	20.34	2.54	24.29	3.05	28.24	3.60	30.15	3.94	32.06	4.18	36.01	4.80	39.96	5.49
	0	20.34	2.58	24.29	3.09	28.24	3.66	30.15	3.98	32.06	4.23	36.01	4.85	39.96	5.53
	2	20.34	2.61	24.29	3.13	28.24	3.70	30.15	4.05	32.06	4.30	36.01	4.95	39.96	5.62
	4	20.34	2.65	24.29	3.17	28.24	3.76	30.15	4.10	32.06	4.36	36.01	5.03	39.96	5.70
	6	20.34	2.69	24.29	3.23	28.24	3.83	30.15	4.18	32.06	4.43	36.01	5.11	39.96	5.79
	8	20.34	2.74	24.29	3.30	28.24	3.91	30.15	4.23	32.06	4.51	36.01	5.20	39.96	5.85
	10	20.34	2.79	24.29	3.37	28.24	3.98	30.15	4.29	32.06	4.61	36.01	5.27	39.96	5.94
	12	20.34	2.84	24.29	3.43	28.24	4.05	30.15	4.37	32.06	4.70	36.01	5.37	39.96	6.05
	14	20.34	2.89	24.29	3.49	28.24	4.12	30.15	4.45	32.06	4.78	36.01	5.47	39.96	6.16
	16	20.34	2.94	24.29	3.55	28.24	4.21	30.15	4.54	32.06	4.88	36.01	5.58	39.84	6.27
	18	20.34	2.99	24.29	3.62	28.24	4.28	30.15	4.62	32.06	4.98	36.01	5.69	39.36	6.47
	20	20.34	3.05	24.29	3.71	28.24	4.37	30.15	4.72	32.06	5.16	36.01	6.11	38.76	6.77
	21	20.34	3.07	24.29	3.73	28.24	4.44	30.15	4.88	32.06	5.34	36.01	6.33	38.53	6.93
	23	20.34	3.14	24.29	3.88	28.24	4.76	30.15	5.23	32.06	5.73	36.01	6.80	37.93	7.25
	25	20.34	3.31	24.29	4.15	28.24	5.09	30.15	5.60	32.06	6.13	36.01	7.27	37.45	7.56

	27	20.34	3.51	24.29	4.42	28.24	5.43	30.15	5.98	32.06	6.55	36.01	7.78	36.85	7.88
	29	20.34	3.75	24.29	4.71	28.24	5.80	30.15	6.38	32.06	7.00	35.65	8.14	36.37	8.20
	31	20.34	3.98	24.29	5.02	28.24	6.17	30.15	6.81	32.06	7.47	35.06	8.46	35.77	8.53
	33	20.34	4.22	24.29	5.33	28.24	6.59	30.15	7.26	32.06	7.97	34.58	8.78	35.29	8.85
	35	20.34	4.49	24.29	5.67	28.24	7.02	30.15	7.74	32.06	8.49	33.98	9.10	34.70	9.18
	37	20.34	4.76	24.29	6.03	28.24	7.47	30.15	8.24	32.06	9.05	33.38	9.42	34.22	9.49
	39	20.34	5.05	24.29	6.42	28.24	7.94	30.15	8.77	32.06	9.64	32.90	9.75	33.62	9.82
	41	20.34	5.23	24.29	6.71	28.24	8.23	30.15	9.01	32.06	9.70	32.67	10.00	33.39	10.05
	43	20.34	5.48	24.29	7.00	28.24	8.52	30.15	9.24	32.06	9.90	32.51	10.13	33.11	10.21
	45	20.34	5.83	24.29	7.35	28.24	8.87	30.15	9.55	32.06	10.18	32.32	10.23	32.60	10.35
	48	20.34	6.15	24.29	7.69	28.24	9.21	30.15	9.67	32.06	10.27	35.61	10.38	35.24	10.49
	80%	-5	18.07	2.22	21.54	2.62	25.00	3.10	26.80	3.30	28.60	3.55	32.06	4.11	35.53
-2		18.07	2.25	21.54	2.65	25.00	3.13	26.80	3.35	28.60	3.58	32.06	4.14	35.53	4.73
0		18.07	2.29	21.54	2.68	25.00	3.17	26.80	3.39	28.60	3.65	32.06	4.20	35.53	4.80
2		18.07	2.33	21.54	2.72	25.00	3.21	26.80	3.45	28.60	3.71	32.06	4.29	35.53	4.89
4		18.07	2.37	21.54	2.77	25.00	3.27	26.80	3.53	28.60	3.78	32.06	4.37	35.53	4.95
6		18.07	2.41	21.54	2.83	25.00	3.32	26.80	3.61	28.60	3.85	32.06	4.43	35.53	5.04
8		18.07	2.46	21.54	2.90	25.00	3.40	26.80	3.67	28.60	3.94	32.06	4.50	35.53	5.13
10		18.07	2.48	21.54	2.97	25.00	3.49	26.80	3.76	28.60	4.03	32.06	4.60	35.53	5.19
12		18.07	2.51	21.54	3.01	25.00	3.55	26.80	3.83	28.60	4.11	32.06	4.69	35.53	5.28
14		18.07	2.56	21.54	3.07	25.00	3.61	26.80	3.89	28.60	4.19	32.06	4.77	35.53	5.38
16		18.07	2.60	21.54	3.12	25.00	3.68	26.80	3.97	28.60	4.26	32.06	4.87	35.53	5.48
18		18.07	2.65	21.54	3.19	25.00	3.76	26.80	4.05	28.60	4.34	32.06	4.97	35.53	5.59
20		18.07	2.70	21.54	3.25	25.00	3.83	26.80	4.12	28.60	4.43	32.06	5.15	35.53	5.98
21		18.07	2.72	21.54	3.27	25.00	3.87	26.80	4.17	28.60	4.53	32.06	5.33	35.53	6.20
23		18.07	2.77	21.54	3.34	25.00	4.05	26.80	4.44	28.60	4.84	32.06	5.71	35.53	6.65
25		18.07	2.86	21.54	3.55	25.00	4.33	26.80	4.75	28.60	5.17	32.06	6.11	35.53	7.11
27		18.07	3.04	21.54	3.78	25.00	4.61	26.80	5.06	28.60	5.53	32.06	6.53	35.53	7.61
29		18.07	3.23	21.54	4.03	25.00	4.92	26.80	5.39	28.60	5.91	32.06	6.97	35.53	8.14
31		18.07	3.43	21.54	4.28	25.00	5.24	26.80	5.75	28.60	6.30	32.06	7.44	34.94	8.46
33		18.07	3.65	21.54	4.55	25.00	5.58	26.80	6.13	28.60	6.70	32.06	7.93	34.46	8.77
35		18.07	3.87	21.54	4.84	25.00	5.93	26.80	6.52	28.60	7.14	32.06	8.46	33.86	9.09
37		18.07	4.10	21.54	5.14	25.00	6.31	26.80	6.94	28.60	7.60	32.06	9.02	33.38	9.41
39		18.07	4.34	21.54	5.48	25.00	6.71	26.80	7.38	28.60	8.09	32.06	9.60	32.78	9.74
41		18.07	4.44	21.54	5.53	25.00	6.81	26.80	7.58	28.60	8.24	32.06	9.85	32.58	9.91
43		18.07	4.57	21.54	5.58	25.00	6.91	26.80	7.71	28.60	8.35	32.06	9.96	32.38	10.01
45		18.07	4.70	21.54	5.64	25.00	7.04	26.80	7.87	28.60	8.50	32.06	10.07	31.98	10.18
48		18.07	4.86	21.54	5.68	28.13	7.15	26.80	7.98	28.60	8.57	32.06	10.17	35.67	10.32
70%		-5	15.79	1.98	18.90	2.32	21.90	2.63	23.45	2.82	25.00	3.01	28.00	3.44	31.11
	-2	15.79	1.99	18.90	2.33	21.90	2.64	23.45	2.87	25.00	3.06	28.00	3.49	31.11	4.01
	0	15.79	2.00	18.90	2.36	21.90	2.70	23.45	2.93	25.00	3.12	28.00	3.56	31.11	4.06
	2	15.79	2.02	18.90	2.37	21.90	2.74	23.45	2.98	25.00	3.17	28.00	3.64	31.11	4.13
	4	15.79	2.04	18.90	2.43	21.90	2.80	23.45	3.03	25.00	3.24	28.00	3.70	31.11	4.23
	6	15.79	2.08	18.90	2.47	21.90	2.87	23.45	3.13	25.00	3.32	28.00	3.77	31.11	4.31
	8	15.79	2.11	18.90	2.55	21.90	2.94	23.45	3.18	25.00	3.39	28.00	3.87	31.11	4.39
	10	15.79	2.16	18.90	2.59	21.90	3.01	23.45	3.25	25.00	3.48	28.00	3.95	31.11	4.44
	12	15.79	2.21	18.90	2.62	21.90	3.08	23.45	3.31	25.00	3.54	28.00	4.03	31.11	4.53
	14	15.79	2.25	18.90	2.67	21.90	3.12	23.45	3.36	25.00	3.60	28.00	4.10	31.11	4.61
	16	15.79	2.28	18.90	2.72	21.90	3.18	23.45	3.43	25.00	3.67	28.00	4.17	31.11	4.70
	18	15.79	2.32	18.90	2.77	21.90	3.25	23.45	3.49	25.00	3.73	28.00	4.26	31.11	4.80
	20	15.79	2.36	18.90	2.82	21.90	3.31	23.45	3.55	25.00	3.81	28.00	4.34	31.11	4.93
	21	15.79	2.38	18.90	2.84	21.90	3.33	23.45	3.59	25.00	3.84	28.00	4.41	31.11	5.10
	23	15.79	2.42	18.90	2.89	21.90	3.40	23.45	3.71	25.00	4.04	28.00	4.72	31.11	5.47
	25	15.79	2.47	18.90	3.01	21.90	3.62	23.45	3.97	25.00	4.31	28.00	5.05	31.11	5.84
	27	15.79	2.61	18.90	3.21	21.90	3.87	23.45	4.22	25.00	4.60	28.00	5.39	31.11	6.25
	29	15.79	2.77	18.90	3.40	21.90	4.11	23.45	4.50	25.00	4.89	28.00	5.75	31.11	6.67
	31	15.79	2.93	18.90	3.61	21.90	4.38	23.45	4.78	25.00	5.21	28.00	6.13	31.11	7.11
	33	15.79	3.11	18.90	3.84	21.90	4.66	23.45	5.09	25.00	5.55	28.00	6.53	31.11	7.59
	35	15.79	3.29	18.90	4.08	21.90	4.94	23.45	5.42	25.00	5.91	28.00	6.96	31.11	8.09
	37	15.79	3.48	18.90	4.32	21.90	5.26	23.45	5.75	25.00	6.28	28.00	7.41	31.11	8.62
	39	15.79	3.69	18.90	4.58	21.90	5.58	23.45	6.11	25.00	6.67	28.00	7.87	31.11	9.18
	41	15.79	3.85	18.90	4.74	21.90	5.74	23.45	6.32	25.00	6.88	28.00	8.20	31.11	9.58
	43	15.79	4.16	18.90	5.06	21.90	5.98	23.45	6.66	25.00	7.08	28.00	8.49	31.11	9.88
	45	15.79	4.25	18.90	5.17	21.90	6.10	23.45	6.76	25.00	7.43	28.00	8.95	31.11	10.26
	48	15.79	4.36	18.90	5.22	21.90	6.16	23.45	6.87	25.00	7.64	28.00	9.36	31.11	10.50

60%	-5	13.52	1.69	16.15	1.96	18.78	2.28	20.10	2.43	21.42	2.62	24.05	2.95	26.68	3.38
	-2	13.52	1.70	16.15	1.99	18.78	2.32	20.10	2.46	21.42	2.65	24.05	2.99	26.68	3.40
	0	13.52	1.72	16.15	2.01	18.78	2.35	20.10	2.50	21.42	2.69	24.05	3.03	26.68	3.44
	2	13.52	1.75	16.15	2.06	18.78	2.40	20.10	2.54	21.42	2.73	24.05	3.10	26.68	3.49
	4	13.52	1.80	16.15	2.10	18.78	2.44	20.10	2.57	21.42	2.77	24.05	3.14	26.68	3.54
	6	13.52	1.82	16.15	2.14	18.78	2.49	20.10	2.63	21.42	2.83	24.05	3.21	26.68	3.62
	8	13.52	1.85	16.15	2.17	18.78	2.54	20.10	2.68	21.42	2.88	24.05	3.27	26.68	3.68
	10	13.52	1.89	16.15	2.22	18.78	2.57	20.10	2.76	21.42	2.94	24.05	3.33	26.68	3.73
	12	13.52	1.93	16.15	2.26	18.78	2.62	20.10	2.81	21.42	2.99	24.05	3.39	26.68	3.79
	14	13.52	1.95	16.15	2.29	18.78	2.66	20.10	2.85	21.42	3.05	24.05	3.45	26.68	3.87
	16	13.52	1.98	16.15	2.33	18.78	2.71	20.10	2.90	21.42	3.10	24.05	3.51	26.68	3.94
	18	13.52	2.01	16.15	2.37	18.78	2.76	20.10	2.95	21.42	3.16	24.05	3.57	26.68	4.01
	20	13.52	2.04	16.15	2.42	18.78	2.81	20.10	3.01	21.42	3.22	24.05	3.65	26.68	4.10
	21	13.52	2.06	16.15	2.43	18.78	2.83	20.10	3.04	21.42	3.25	24.05	3.68	26.68	4.14
	23	13.52	2.09	16.15	2.48	18.78	2.88	20.10	3.10	21.42	3.31	24.05	3.83	26.68	4.40
	25	13.52	2.12	16.15	2.51	18.78	2.99	20.10	3.25	21.42	3.51	24.05	4.09	26.68	4.70
	27	13.52	2.21	16.15	2.67	18.78	3.18	20.10	3.46	21.42	3.75	24.05	4.36	26.68	5.01
	29	13.52	2.33	16.15	2.83	18.78	3.39	20.10	3.68	21.42	3.99	24.05	4.65	26.68	5.36
	31	13.52	2.48	16.15	3.00	18.78	3.60	20.10	3.92	21.42	4.25	24.05	4.94	26.68	5.70
	33	13.52	2.61	16.15	3.18	18.78	3.82	20.10	4.16	21.42	4.51	24.05	5.26	26.68	6.08
35	13.52	2.77	16.15	3.38	18.78	4.05	20.10	4.42	21.42	4.79	24.05	5.60	26.68	6.47	
37	13.52	2.93	16.15	3.57	18.78	4.29	20.10	4.69	21.42	5.09	24.05	5.95	26.68	6.88	
39	13.52	3.09	16.15	3.78	18.78	4.55	20.10	4.97	21.42	5.40	24.05	6.32	26.68	7.32	
41	13.52	3.19	16.15	3.95	18.78	4.72	20.10	5.16	21.42	5.60	24.05	6.62	26.68	7.65	
43	13.52	3.29	16.15	4.11	18.78	4.88	20.10	5.32	21.42	5.80	24.05	6.90	26.68	7.98	
45	13.52	3.44	16.15	4.32	18.78	5.08	20.10	5.52	21.42	6.09	24.05	7.21	26.68	8.42	
48	13.52	3.57	16.15	4.51	18.78	5.25	20.10	5.66	21.42	6.32	24.05	7.47	26.68	8.82	
50%	-5	11.31	1.47	13.52	1.69	15.67	1.95	16.75	2.04	17.83	2.15	19.98	2.45	22.25	2.64
	-2	11.31	1.48	13.52	1.73	15.67	1.97	16.75	2.07	17.83	2.19	19.98	2.48	22.25	2.67
	0	11.31	1.50	13.52	1.76	15.67	2.00	16.75	2.09	17.83	2.21	19.98	2.52	22.25	2.72
	2	11.31	1.52	13.52	1.78	15.67	2.04	16.75	2.13	17.83	2.25	19.98	2.53	22.25	2.77
	4	11.31	1.54	13.52	1.81	15.67	2.06	16.75	2.15	17.83	2.30	19.98	2.59	22.25	2.84
	6	11.31	1.56	13.52	1.84	15.67	2.09	16.75	2.20	17.83	2.34	19.98	2.63	22.25	2.92
	8	11.31	1.60	13.52	1.87	15.67	2.13	16.75	2.25	17.83	2.37	19.98	2.68	22.25	3.02
	10	11.31	1.63	13.52	1.89	15.67	2.16	16.75	2.28	17.83	2.44	19.98	2.75	22.25	3.06
	12	11.31	1.65	13.52	1.92	15.67	2.20	16.75	2.33	17.83	2.49	19.98	2.79	22.25	3.11
	14	11.31	1.67	13.52	1.94	15.67	2.22	16.75	2.38	17.83	2.53	19.98	2.84	22.25	3.17
	16	11.31	1.70	13.52	1.96	15.67	2.26	16.75	2.42	17.83	2.56	19.98	2.89	22.25	3.22
	18	11.31	1.72	13.52	2.00	15.67	2.29	16.75	2.45	17.83	2.61	19.98	2.94	22.25	3.28
	20	11.31	1.74	13.52	2.03	15.67	2.33	16.75	2.49	17.83	2.66	19.98	2.99	22.25	3.34
	21	11.31	1.76	13.52	2.05	15.67	2.35	16.75	2.51	17.83	2.68	19.98	3.03	22.25	3.38
	23	11.31	1.78	13.52	2.07	15.67	2.39	16.75	2.56	17.83	2.73	19.98	3.07	22.25	3.45
	25	11.31	1.81	13.52	2.11	15.67	2.44	16.75	2.61	17.83	2.82	19.98	3.23	22.25	3.68
	27	11.31	1.84	13.52	2.20	15.67	2.57	16.75	2.78	17.83	2.99	19.98	3.44	22.25	3.93
	29	11.31	1.94	13.52	2.32	15.67	2.73	16.75	2.95	17.83	3.18	19.98	3.66	22.25	4.19
	31	11.31	2.05	13.52	2.45	15.67	2.89	16.75	3.14	17.83	3.38	19.98	3.89	22.25	4.45
	33	11.31	2.17	13.52	2.60	15.67	3.07	16.75	3.32	17.83	3.59	19.98	4.14	22.25	4.73
35	11.31	2.29	13.52	2.75	15.67	3.25	16.75	3.51	17.83	3.79	19.98	4.39	22.25	5.03	
37	11.31	2.42	13.52	2.90	15.67	3.44	16.75	3.72	17.83	4.03	19.98	4.66	22.25	5.34	
39	11.31	2.55	13.52	3.06	15.67	3.64	16.75	3.94	17.83	4.27	19.98	4.94	22.25	5.67	
41	11.31	2.66	13.52	3.19	15.67	3.77	16.75	4.13	17.83	4.45	19.98	5.21	22.25	5.94	
43	11.31	2.83	13.52	3.41	15.67	3.90	16.75	4.31	17.83	4.57	19.98	5.47	22.25	6.20	
45	11.31	2.90	13.52	3.50	15.67	4.16	16.75	4.64	17.83	4.76	19.98	6.00	22.25	6.73	
48	11.31	2.96	13.52	3.60	15.67	4.41	16.75	4.94	17.83	4.97	19.98	6.48	22.25	7.24	

12HP heating mode

Combination (Capacity index)	Outdoor air temp.		Indoor temperature(°C DB)											
			16		18		20		21		22		24	
	°C DB	°C WB	kW	PI	kW	PI	kW	PI	kW	PI	kW	PI	kW	PI
130%	-19.8	-20	24.28	6.35	24.16	6.80	24.05	7.25	24.05	7.47	23.93	7.69	23.93	8.15
	-18.8	-19	24.64	6.49	24.52	6.94	24.52	7.38	24.40	7.60	24.40	7.81	24.28	8.25
	-16.7	-17	25.59	6.80	25.47	7.22	25.35	7.65	25.35	7.86	25.35	8.07	25.24	8.49
	-13.7	-15	26.66	7.11	26.55	7.52	26.43	7.93	26.43	8.13	26.31	8.34	26.31	8.75
	-11.8	-13	27.74	7.43	27.74	7.82	27.62	8.21	27.50	8.41	27.50	8.60	27.38	8.99
	-9.8	-11	29.05	7.75	28.93	8.13	28.81	8.50	28.81	8.69	28.81	8.87	28.69	9.25
	-9.5	-10	29.76	7.92	29.64	8.28	29.52	8.64	29.52	8.83	29.40	9.00	29.40	9.36
	-8.5	-9.1	30.35	8.06	30.24	8.41	30.24	8.77	30.12	8.94	30.12	9.12	30.00	9.48
	-7	-7.6	31.43	8.29	31.43	8.64	31.31	8.98	31.31	9.15	31.19	9.32	31.07	9.67
	-5	-5.6	33.09	8.60	32.97	8.93	32.85	9.26	32.85	9.42	32.74	9.57	32.74	9.90
	-3	-3.7	34.64	8.88	34.52	9.20	34.52	9.50	34.40	9.67	34.40	9.82	34.28	10.12
	0	-0.7	37.38	9.32	37.38	9.61	37.26	9.89	37.26	9.99	37.14	10.18	37.14	10.46
	3	2.2	40.35	9.70	40.24	9.97	40.12	10.24	40.12	10.37	40.12	10.51	40.00	10.76
	5	4.1	42.38	9.95	42.26	10.20	42.26	10.45	42.14	10.58	42.14	10.71	42.02	10.95
	7	6	44.52	10.18	44.40	10.41	44.40	10.66	44.28	10.78	44.28	10.89	42.50	10.46
	9	7.9	46.78	10.39	46.66	10.62	46.66	10.85	46.55	10.96	45.59	10.73	42.50	9.83
	11	9.8	49.16	10.60	49.05	10.81	48.81	10.95	47.14	10.52	45.59	10.09	42.50	9.26
13	11.8	51.78	10.80	51.66	11.01	48.81	10.26	47.14	9.85	45.59	9.47	42.50	8.69	
15	13.7	54.28	10.99	51.90	10.43	48.81	9.67	47.14	9.29	45.59	8.92	42.50	8.20	
120%	-19.8	-20	24.17	6.96	24.05	7.37	23.93	7.79	23.93	7.99	23.93	8.20	23.81	8.62
	-18.8	-19	24.53	7.09	24.41	7.50	24.41	7.90	24.29	8.10	24.29	8.31	24.17	8.72
	-16.7	-17	25.48	7.37	25.36	7.76	25.20	8.15	25.24	8.35	25.24	8.55	25.12	8.93
	-13.7	-15	26.55	7.66	26.43	8.03	26.31	8.41	26.31	8.61	26.31	8.79	26.19	9.17
	-11.8	-13	27.62	7.95	27.62	8.31	27.50	8.68	27.50	8.86	27.38	9.04	27.38	9.40
	-9.8	-11	28.93	8.25	28.81	8.59	28.81	8.94	28.69	9.12	28.69	9.28	28.57	9.63
	-9.5	-10	29.65	8.41	29.53	8.75	29.41	9.07	29.41	9.25	29.41	9.41	29.29	9.75
	-8.5	-9.1	30.24	8.53	30.12	8.86	30.12	9.19	30.00	9.35	30.00	9.53	29.88	9.85
	-7	-7.6	31.31	8.76	31.31	9.07	31.19	9.39	31.19	9.55	31.07	9.70	31.07	10.02
	-5	-5.6	32.98	9.04	32.86	9.34	32.74	9.64	32.74	9.80	32.74	9.95	32.62	10.24
	-3	-3.7	34.53	9.31	34.53	9.60	34.41	9.88	34.41	10.02	34.29	10.17	34.29	10.45
	0	-0.7	37.26	9.70	37.26	9.97	37.14	10.23	37.14	10.37	37.02	10.50	37.02	10.76
	3	2.2	40.24	10.06	40.12	10.31	40.12	10.55	40.00	10.68	40.00	10.80	39.17	10.74
	5	4.1	42.26	10.29	42.14	10.52	42.14	10.75	42.02	10.87	42.02	10.99	39.17	10.09
	7	6	44.41	10.50	44.41	10.72	44.29	10.94	43.57	10.79	42.14	10.34	39.17	9.49
	9	7.9	46.67	10.71	46.55	10.92	45.00	10.55	43.57	10.14	42.14	9.73	39.17	8.93
	11	9.8	49.05	10.89	47.86	10.71	45.00	9.92	43.57	9.54	42.14	9.15	39.17	8.42
13	11.8	50.83	10.79	47.86	10.04	45.00	9.31	43.57	8.96	42.14	8.61	39.17	7.92	
15	13.7	50.83	10.16	47.86	9.46	45.00	8.78	43.57	8.44	42.14	8.11	39.17	7.47	
110%	-19.8	-20	24.05	7.57	23.93	7.94	23.81	8.32	23.81	8.51	23.82	8.70	23.69	9.08
	-18.8	-19	24.41	7.68	24.29	8.06	24.29	8.43	24.29	8.62	24.17	8.80	24.17	9.18
	-16.7	-17	25.36	7.94	25.24	8.30	25.59	8.66	25.12	8.84	25.12	9.03	25.00	9.38
	-13.7	-15	26.43	8.21	26.31	8.56	26.19	8.90	26.19	9.07	26.19	9.25	26.07	9.59
	-11.8	-13	27.50	8.49	27.50	8.81	27.38	9.14	27.38	9.31	27.26	9.47	27.26	9.81
	-9.8	-11	28.81	8.76	28.69	9.07	28.69	9.39	28.57	9.55	28.57	9.70	28.57	10.02
	-9.5	-10	29.52	8.90	29.40	9.20	29.28	9.52	29.28	9.67	29.28	9.82	29.17	10.12
	-8.5	-9.1	30.12	9.01	30.00	9.32	30.00	9.62	29.88	9.77	29.88	9.92	29.88	9.05
	-7	-7.6	31.19	9.22	31.19	9.50	31.07	9.80	31.07	9.95	31.07	10.09	30.95	10.38
	-5	-5.6	32.86	9.48	32.74	9.76	32.62	10.03	32.62	10.17	32.62	10.31	32.50	10.59
	-3	-3.7	34.41	9.73	34.41	9.98	34.29	10.25	34.29	10.38	34.17	10.51	34.17	10.78
	0	-0.7	37.14	10.09	37.14	10.33	37.03	10.58	37.03	10.69	37.03	10.82	35.95	10.61
	3	2.2	40.12	10.43	40.00	10.65	40.00	10.87	39.88	10.98	38.57	10.53	35.95	9.66
	5	4.1	42.14	10.62	42.14	10.85	41.31	10.74	39.88	10.31	38.57	9.90	35.95	9.08
	7	6	44.28	10.82	43.93	10.89	41.31	10.09	39.88	9.69	38.57	9.31	35.95	8.55
	9	7.9	46.55	11.00	43.93	10.24	41.31	9.49	39.88	9.12	38.57	8.76	35.95	8.06
	11	9.8	46.55	10.34	43.93	9.63	41.31	8.93	39.88	8.59	38.57	8.25	35.95	7.60
13	11.8	46.55	9.70	43.93	9.04	41.31	8.39	39.88	8.08	38.57	7.76	35.95	7.16	
15	13.7	46.55	8.62	43.93	8.52	41.31	7.93	39.88	7.62	38.57	7.34	35.95	6.77	
100%	-19.8	-20	23.93	8.17	23.81	8.51	23.81	8.86	23.69	9.04	23.69	9.20	23.57	9.55
	-18.8	-19	24.29	8.28	24.29	8.62	24.17	8.95	24.17	9.13	24.05	9.31	24.05	9.64

	-16.7	-17	25.24	8.51	25.12	8.84	25.12	9.17	25.00	9.33	25.00	9.49	25.00	9.82
	-13.7	-15	26.31	8.76	26.19	9.07	26.07	9.39	26.07	9.55	26.07	9.70	25.95	10.02
	-11.8	-13	27.38	9.01	27.38	9.31	27.26	9.61	27.26	9.76	27.26	9.91	27.14	10.22
	-9.8	-11	28.69	9.26	28.57	9.55	28.57	9.83	28.57	9.98	28.45	10.12	28.45	10.40
	-9.5	-10	29.40	9.39	29.29	9.67	29.29	9.95	29.17	10.09	29.17	10.23	29.05	10.51
	-8.5	-9.1	30.00	9.49	29.88	9.77	29.88	10.04	29.88	10.18	29.76	10.32	29.76	10.59
	-7	-7.6	31.07	9.68	31.07	9.95	30.95	10.20	30.95	10.34	30.95	10.47	30.83	10.74
	-5	-5.6	32.74	9.92	32.62	10.17	32.62	10.43	32.50	10.54	32.50	10.67	32.38	10.93
	-3	-3.7	34.29	10.15	34.29	9.21	34.17	10.62	34.17	10.74	34.17	10.86	32.74	10.40
	0	-0.7	37.02	10.47	37.02	10.69	36.90	10.92	36.31	10.74	35.12	10.30	32.74	9.44
	3	2.2	40.00	10.78	39.88	10.97	37.50	10.16	36.31	9.76	35.12	9.38	32.74	8.60
	5	4.1	42.02	10.97	39.88	10.31	37.50	9.55	36.31	9.19	35.12	8.83	32.74	8.11
	7	6	42.26	10.41	39.88	9.69	37.50	8.99	36.31	8.65	35.12	8.31	32.74	7.65
	9	7.9	42.26	9.78	39.88	9.12	37.50	8.46	36.31	8.04	35.12	7.83	32.74	7.22
	11	9.8	42.26	9.21	39.88	8.59	37.50	7.99	36.31	7.68	35.12	7.39	32.74	6.82
	13	11.8	42.26	8.65	39.88	8.08	37.50	7.52	36.31	7.24	35.12	6.97	32.74	6.43
	15	13.7	42.26	8.16	39.88	7.62	37.50	7.10	36.31	6.84	35.12	6.59	32.74	6.09
90%	-19.8	-20	23.77	8.78	23.65	9.08	23.65	9.40	23.53	9.55	23.53	9.71	23.53	10.02
	-18.8	-19	24.12	8.87	24.12	9.19	24.01	9.49	24.01	9.64	24.01	9.80	23.88	10.10
	-16.7	-17	25.08	9.09	24.95	9.39	24.95	9.68	24.95	9.83	24.84	9.97	24.84	10.26
	-13.7	-15	26.14	9.32	26.02	9.60	26.02	9.88	25.91	10.02	25.91	10.16	25.91	10.44
	-11.8	-13	27.21	9.54	27.21	9.81	27.09	10.08	27.09	10.22	27.09	10.34	26.98	10.61
	-9.8	-11	28.52	9.76	28.52	10.02	28.40	10.27	28.40	10.40	28.40	10.54	28.28	10.80
	-9.5	-10	29.23	9.88	29.12	10.13	29.12	10.38	29.00	10.51	29.00	10.64	29.00	10.88
	-8.5	-9.1	29.83	9.98	29.83	10.23	29.71	10.47	29.71	10.59	29.71	10.72	29.35	10.82
	-7	-7.6	30.90	10.15	30.90	10.38	30.78	10.62	30.78	10.74	30.78	10.86	29.35	10.33
	-5	-5.6	32.56	10.37	32.44	10.59	32.44	10.81	32.32	10.93	31.49	10.59	29.35	9.71
	-3	-3.7	34.11	10.57	34.11	10.78	33.75	10.82	32.56	10.39	31.49	9.97	29.35	9.15
	0	-0.7	36.96	10.87	35.89	10.60	33.75	9.82	32.56	9.43	31.49	9.06	29.35	8.32
	3	2.2	38.03	10.36	35.89	9.64	33.75	8.94	32.56	8.60	31.49	8.27	29.35	7.61
	5	4.1	38.03	9.74	35.89	9.07	33.75	8.43	32.56	8.10	31.49	7.80	29.35	7.18
	7	6	38.03	9.15	35.89	8.55	33.75	7.94	32.56	7.65	31.49	7.36	29.35	6.78
	9	7.9	38.03	8.63	35.89	8.04	33.75	7.48	32.56	7.22	31.49	6.95	29.35	6.41
	11	9.8	38.03	8.13	35.89	7.59	33.75	7.08	32.56	6.82	31.49	6.56	29.35	6.07
	13	11.8	38.03	7.65	35.89	7.16	33.75	6.67	32.56	6.43	31.49	6.20	29.35	5.73
	15	13.7	38.03	7.23	35.89	6.76	33.75	6.32	32.56	6.09	31.49	5.87	29.35	5.44
80%	-19.8	-20	23.69	9.39	23.57	9.66	23.57	9.94	23.57	10.08	23.45	10.22	23.45	10.48
	-18.8	-19	24.05	9.47	24.05	9.75	23.93	10.02	23.93	10.16	23.93	10.29	23.81	10.57
	-16.7	-17	25.00	9.67	24.88	9.92	24.88	10.19	24.88	10.32	24.88	10.45	24.76	10.71
	-13.7	-15	26.07	9.87	25.95	10.11	25.95	10.37	25.95	10.48	25.83	10.61	25.83	10.87
	-11.8	-13	27.14	10.06	27.14	10.31	27.02	10.54	27.02	10.66	27.02	10.79	26.19	10.50
	-9.8	-11	28.45	10.26	28.45	10.50	28.33	10.73	28.33	10.83	28.10	10.81	26.19	9.91
	-9.5	-10	29.17	10.37	29.04	10.59	29.05	10.81	29.05	10.93	28.10	10.50	26.19	9.62
	-8.5	-9.1	29.76	10.46	27.66	10.68	29.64	10.89	29.05	10.65	28.10	10.22	26.19	9.36
	-7	-7.6	30.83	10.61	30.83	10.82	30.00	10.59	29.05	10.17	28.10	9.76	26.19	8.95
	-5	-5.6	32.50	10.80	31.91	10.74	30.00	9.95	29.05	9.56	28.10	9.18	26.19	8.43
	-3	-3.7	33.81	10.86	31.91	10.11	30.00	9.36	29.05	9.01	28.10	8.65	26.19	7.96
	0	-0.7	33.81	9.85	31.91	9.18	30.00	8.52	29.05	8.21	28.10	7.88	26.19	7.26
	3	2.2	33.81	8.98	31.91	8.37	30.00	7.79	29.05	7.50	28.10	7.22	26.19	6.65
	5	4.1	33.81	8.45	31.91	7.89	30.00	7.34	29.05	7.07	28.10	6.82	26.19	6.29
	7	6	33.81	7.96	31.91	7.45	30.00	6.93	29.05	6.69	28.10	6.44	26.19	5.95
	9	7.9	33.81	7.52	31.91	7.03	30.00	6.55	29.05	6.32	28.10	6.09	26.19	5.64
	11	9.8	33.81	7.10	31.91	6.64	30.00	6.20	29.05	5.98	28.10	5.77	26.19	5.35
	13	11.8	33.81	6.69	31.91	6.27	30.00	5.86	29.05	5.65	28.10	5.45	26.19	5.06
	15	13.7	33.81	6.33	31.91	5.94	30.00	5.56	29.05	5.36	28.10	5.17	26.19	4.81
70%	-19.8	-20	23.52	9.99	23.40	10.23	23.40	10.47	23.40	10.59	23.40	10.72	22.81	10.60
	-18.8	-19	23.87	10.07	23.87	10.31	23.76	10.54	23.76	10.66	23.76	10.79	22.81	10.38
	-16.7	-17	24.82	10.24	24.82	10.47	24.71	10.69	24.71	10.81	24.47	9.63	22.81	9.90
	-13.7	-15	25.89	10.41	25.77	10.64	25.77	10.86	25.30	10.69	24.47	10.26	22.81	9.41
	-11.8	-13	26.96	10.59	26.96	10.80	26.25	10.54	25.30	10.13	24.47	9.73	22.81	8.92
	-9.8	-11	28.27	10.76	27.91	10.75	26.25	9.96	25.30	9.57	24.47	9.19	22.81	8.44
	-9.5	-10	28.98	10.86	27.91	10.44	26.25	9.67	25.30	9.29	24.47	8.93	22.81	8.21
	-8.5	-9.1	29.58	10.92	27.91	10.16	26.25	9.41	25.30	9.05	24.47	8.70	22.81	8.00
	-7	-7.6	29.58	10.43	27.91	9.70	26.25	9.00	25.30	8.66	24.47	8.32	22.81	7.66
	-5	-5.6	29.58	9.80	27.91	9.13	26.25	8.48	25.30	8.15	24.47	7.93	22.81	7.23

	-3	-3.7	29.58	9.22	27.91	8.60	26.25	8.00	25.30	7.69	24.47	7.40	22.81	6.83
	0	-0.7	29.58	8.39	27.91	7.85	26.25	7.30	25.30	7.03	24.47	6.77	22.81	6.26
	3	2.2	29.58	7.67	27.91	7.18	26.25	6.69	25.30	6.44	24.47	6.21	22.81	5.74
	5	4.1	29.58	7.24	27.91	6.77	26.25	6.33	25.30	6.09	24.47	5.87	22.81	5.44
	7	6	29.58	6.84	27.91	6.41	26.25	5.98	25.30	5.77	24.47	5.57	22.81	5.16
	9	7.9	29.58	6.47	27.91	6.06	26.25	5.66	25.30	5.46	24.47	5.28	22.81	4.89
	11	9.8	29.58	6.12	27.91	5.73	26.25	5.37	25.30	5.18	24.47	5.01	22.81	4.65
	13	11.8	29.58	5.78	27.91	5.43	26.25	5.08	25.30	4.92	24.47	4.74	22.81	4.41
	15	13.7	29.58	5.48	27.91	5.15	26.25	4.82	25.30	4.67	24.47	4.51	22.81	4.20
60%	-19.8	-20	23.45	10.60	23.33	10.80	22.50	10.39	21.79	9.98	21.07	9.58	19.64	8.79
	-18.8	-19	23.81	10.67	23.81	10.87	22.50	10.17	21.79	9.77	21.07	9.37	19.64	8.60
	-16.7	-17	24.76	10.81	23.93	10.47	22.50	9.70	21.79	9.33	21.07	8.95	19.64	8.23
	-13.7	-15	25.36	10.69	23.93	9.95	22.50	9.22	21.79	8.87	21.07	8.52	19.64	7.83
	-11.8	-13	25.36	10.12	23.93	9.42	22.50	8.74	21.79	8.42	21.07	8.09	19.64	7.48
	-9.8	-11	25.36	9.56	23.93	8.91	22.50	8.28	21.79	7.96	21.07	7.66	19.64	7.06
	-9.5	-10	25.36	9.29	23.93	8.66	22.50	8.04	21.79	7.75	21.07	7.45	19.64	6.86
	-8.5	-9.1	25.36	9.05	23.93	8.44	22.50	7.85	21.79	7.55	21.07	7.26	19.64	6.70
	-7	-7.6	25.36	8.65	23.93	8.08	22.50	7.51	21.79	7.24	21.07	6.96	19.64	6.43
	-5	-5.6	25.36	8.15	23.93	7.61	22.50	7.09	21.79	6.83	21.07	6.57	19.64	6.08
	-3	-3.7	25.36	7.69	23.93	7.19	22.50	6.70	21.79	6.47	21.07	6.22	19.64	5.76
	0	-0.7	25.36	7.03	23.93	6.58	22.50	6.14	21.79	5.93	21.07	5.71	19.64	5.29
	3	2.2	25.36	6.44	23.93	6.05	22.50	5.65	21.79	5.45	21.07	5.27	19.64	4.88
	5	4.1	25.36	6.09	23.93	5.72	22.50	5.35	21.79	5.17	21.07	4.99	19.64	4.63
	7	6	25.36	5.77	23.93	5.42	22.50	5.07	21.79	4.90	21.07	4.74	19.64	4.40
9	7.9	25.36	5.46	23.93	5.14	22.50	4.81	21.79	4.66	21.07	4.49	19.64	4.19	
11	9.8	25.36	5.18	23.93	4.88	22.50	4.58	21.79	4.42	21.07	4.27	19.64	3.99	
13	11.8	25.36	4.90	23.93	4.62	22.50	4.34	21.79	4.20	21.07	4.06	19.64	3.79	
15	13.7	25.36	4.67	23.93	4.39	22.50	4.13	21.79	4.00	21.07	3.88	19.64	3.62	
50%	-19.8	-20	21.12	9.64	19.94	8.98	18.75	8.34	18.04	8.03	17.45	7.72	16.26	7.11
	-18.8	-19	21.12	9.43	19.94	8.79	18.75	8.17	18.04	7.86	17.45	7.55	16.26	6.97
	-16.7	-17	21.12	9.00	19.94	8.39	18.75	7.81	18.04	7.52	17.45	7.24	16.26	6.68
	-13.7	-15	21.12	8.57	19.94	8.00	18.75	7.44	18.04	7.17	17.45	6.90	16.26	6.37
	-11.8	-13	21.12	8.14	19.94	7.60	18.75	7.07	18.04	6.82	17.45	6.56	16.26	6.07
	-9.8	-11	21.12	7.71	19.94	7.20	18.75	6.71	18.04	6.47	17.45	6.23	16.26	5.77
	-9.5	-10	21.12	7.50	19.94	7.00	18.75	6.54	18.04	6.30	17.45	6.07	16.26	5.62
	-8.5	-9.1	21.12	7.31	19.94	6.84	18.75	6.37	18.04	6.15	17.45	5.93	16.26	5.49
	-7	-7.6	21.12	7.00	19.94	6.56	18.75	6.12	18.04	5.91	17.45	5.70	16.26	5.28
	-5	-5.6	21.12	6.61	19.94	6.20	18.75	5.79	18.04	5.59	17.45	5.39	16.26	5.00
	-3	-3.7	21.12	6.26	19.94	5.87	18.75	5.49	18.04	5.30	17.45	5.11	16.26	4.75
	0	-0.7	21.12	5.74	19.94	5.39	18.75	5.05	18.04	4.88	17.45	4.72	16.26	4.39
	3	2.2	21.12	5.29	19.94	4.97	18.75	4.66	18.04	4.51	17.45	4.35	16.26	4.06
	5	4.1	21.12	5.02	19.94	4.72	18.75	4.42	18.04	4.28	17.45	4.14	16.26	3.86
	7	6	21.12	4.76	19.94	4.48	18.75	4.21	18.04	4.07	17.45	3.95	16.26	3.69
9	7.9	21.12	4.52	19.94	4.26	18.75	4.00	18.04	3.89	17.45	3.76	16.26	3.51	
11	9.8	21.12	4.30	19.94	4.05	18.75	3.82	18.04	3.70	17.45	3.58	16.26	3.35	
13	11.8	21.12	4.09	19.94	3.85	18.75	3.63	18.04	3.53	17.45	3.41	16.26	3.20	
15	13.7	21.12	3.89	19.94	3.68	18.75	3.47	18.04	3.36	17.45	3.26	16.26	3.06	

Note:

1. [] is shown as reference.
2. The above table shows the average value of conditions may operate.
3. It is recommended to connect less than 130%.

14HP cooling mode

Combination (%) (Capacity index)	Outdoor temperature (°C DB)	Indoor temperature(°C DB/WD)													
		DB:20.8,WB:14		DB:23.3,WB:16		DB:25.8,WB:18		DB:27,WB:19		DB:28.2,WB:20		DB:30.7,WB:22		DB:32,WB:24	
		TC	PI	TC	PI	TC	PI	TC	PI	TC	PI	TC	PI	TC	PI
130%	-5	35.14	5.03	41.86	6.14	48.57	6.58	50.43	6.85	52.85	7.04	54.14	7.66	55.50	7.71
	-2	35.14	5.03	41.86	6.26	48.57	6.58	50.43	6.89	52.85	7.04	54.14	7.76	55.50	7.79
	0	35.14	5.12	41.86	6.37	48.57	6.82	50.43	7.27	52.85	7.45	54.14	7.85	55.50	7.89
	2	35.14	5.21	41.86	6.38	48.57	7.06	50.43	7.68	52.85	7.54	54.14	7.91	55.50	8.01
	4	35.14	5.33	41.86	6.51	48.57	7.30	50.43	7.71	52.85	7.64	54.14	7.91	55.50	8.16
	6	35.14	5.43	41.86	6.64	48.57	7.57	50.43	7.77	52.26	7.88	53.48	7.90	54.89	8.22
	8	35.14	5.56	41.86	6.79	48.57	7.95	50.43	8.16	51.62	8.13	52.90	3.90	54.19	8.30
	10	35.14	5.67	41.86	6.93	48.57	8.24	50.43	8.43	51.00	4.04	52.28	4.06	53.57	8.54
	12	35.14	5.77	41.86	7.07	48.57	8.41	49.71	4.03	50.43	4.06	51.57	4.07	52.86	8.59
	14	35.14	5.89	41.86	7.20	48.43	4.05	49.14	4.06	49.71	4.08	51.00	4.09	52.28	8.79
	16	35.14	5.99	41.86	7.35	47.86	4.06	48.43	4.08	49.00	4.10	50.28	4.12	51.57	8.93
	18	35.14	6.10	41.86	7.50	47.14	8.79	47.71	8.84	48.43	8.89	49.71	8.98	51.00	9.06
	20	35.14	6.24	41.86	7.98	46.43	9.22	47.14	9.27	47.71	9.32	49.00	9.41	50.28	9.51
	21	35.14	6.40	41.86	8.26	46.14	9.44	46.85	9.49	47.43	9.54	48.71	9.64	50.00	9.72
	23	35.14	6.87	41.86	8.86	45.57	9.87	46.14	9.92	46.71	9.97	48.00	10.07	49.28	10.17
	25	35.14	7.33	41.86	9.49	44.85	10.30	45.43	10.35	46.14	10.42	47.43	10.52	48.71	10.62
	27	35.14	7.83	41.86	10.15	44.28	10.73	44.85	10.80	45.43	10.85	46.71	10.97	48.00	11.08
	29	35.14	8.36	41.86	10.85	43.57	11.16	44.14	11.23	44.85	11.30	46.14	11.41	47.43	11.53
	31	35.14	8.92	41.71	11.48	42.85	11.61	43.57	11.68	44.14	11.73	45.43	11.86	46.71	11.99
	33	35.14	9.51	41.00	11.91	42.28	12.04	42.85	12.11	43.57	12.18	44.85	12.31	46.00	12.44
	35	35.14	10.14	40.28	12.34	41.57	12.49	42.28	12.56	42.85	12.62	44.14	12.77	45.43	12.91
37	35.14	10.78	39.71	12.79	41.00	12.94	41.57	13.01	42.28	13.09	43.43	13.24	44.71	13.39	
39	35.14	11.48	39.00	12.92	40.28	13.37	41.00	13.45	41.57	13.54	42.85	13.69	44.14	13.85	
41	35.14	12.08	38.60	13.05	39.86	13.50	40.58	13.58	41.15	13.66	42.43	13.71	42.45	13.98	
43	35.14	12.39	38.31	13.11	39.65	13.53	40.36	13.64	40.72	13.68	41.66	13.74	41.94	14.01	
45	35.14	13.00	38.07	13.24	39.23	13.66	39.94	13.73	40.13	13.74	40.53	13.79	41.12	14.27	
48	35.14	13.47	39.43	13.66	42.76	13.79	43.56	13.85	43.91	13.90	43.72	14.02	44.51	14.06	
120%	-5	32.43	4.86	38.57	5.89	44.86	6.96	48.00	7.59	50.29	7.91	51.43	8.17	52.57	8.38
	-2	32.43	4.91	38.57	5.95	44.86	7.03	48.00	7.63	50.29	8.01	51.43	8.23	52.57	8.41
	0	32.43	4.95	38.57	5.99	44.86	7.11	48.00	7.65	50.29	8.08	51.43	8.28	52.57	8.43
	2	32.43	4.96	38.57	6.05	44.86	7.16	48.00	7.73	50.29	8.11	51.43	8.34	52.57	8.45
	4	32.43	5.01	38.57	6.13	44.86	7.26	48.00	7.80	50.29	8.22	51.43	8.36	52.57	8.47
	6	32.43	5.07	38.57	6.17	44.86	7.35	48.00	7.88	50.29	8.31	51.43	8.43	52.57	8.49
	8	32.43	5.11	38.57	6.24	44.86	7.45	48.00	7.98	50.29	8.39	51.43	8.46	52.57	8.54
	10	32.43	5.18	38.57	6.32	44.86	7.51	48.00	8.13	50.29	8.40	51.43	8.48	52.57	8.57
	12	32.43	5.28	38.57	6.44	44.86	7.66	48.00	8.28	49.57	8.43	50.71	8.44	51.86	8.63
	14	32.43	5.38	38.57	6.57	44.86	7.81	48.00	8.44	48.86	8.48	50.14	8.56	51.28	8.73
	16	32.43	5.47	38.57	6.70	44.86	7.96	47.71	4.10	48.28	8.61	49.43	8.71	50.57	8.86
	18	32.43	5.57	38.57	6.83	44.86	8.23	47.00	8.79	47.57	8.82	48.72	8.91	50.00	8.99
	20	32.43	5.69	38.57	7.10	44.86	8.86	46.43	9.22	47.00	9.26	48.14	9.34	49.29	9.42
	21	32.43	5.74	38.57	7.35	44.86	9.17	46.00	9.44	46.57	9.47	47.86	9.56	49.00	9.65
	23	32.43	6.14	38.57	7.88	44.86	9.82	45.43	9.85	46.00	9.90	47.14	10.00	48.28	10.09
	25	32.43	6.55	38.57	8.43	44.14	10.25	44.71	10.28	45.28	10.33	46.57	10.43	47.71	10.53
	27	32.43	7.00	38.57	9.01	43.57	10.67	44.14	10.73	44.71	10.78	45.86	10.88	47.00	10.98
	29	32.43	7.46	38.57	9.62	42.86	11.10	43.43	11.16	44.00	11.21	45.14	11.33	46.43	11.43
	31	32.43	7.96	38.57	10.27	42.14	11.54	42.86	11.59	43.43	11.66	44.57	11.78	45.71	11.89
	33	32.43	8.48	38.57	10.95	41.57	11.98	42.14	12.04	42.71	12.09	43.86	12.23	45.00	12.34
	35	32.43	9.02	38.57	11.68	40.86	12.41	41.43	12.47	42.14	12.54	43.28	12.67	44.43	12.81
37	32.43	9.60	38.57	12.44	40.28	12.86	40.86	12.92	41.43	12.99	42.57	13.12	43.71	13.27	
39	32.43	10.22	38.43	13.14	39.57	13.29	40.14	13.37	40.72	13.44	42.00	13.59	43.14	13.72	
41	32.43	10.50	38.12	13.23	39.26	13.38	39.83	13.46	40.40	13.53	41.69	13.62	41.90	13.82	
43	32.43	10.65	37.91	13.32	38.95	13.46	39.52	13.51	40.09	13.58	40.96	13.66	41.25	14.10	
45	32.43	10.78	37.71	13.45	38.58	13.59	39.11	13.64	39.74	13.68	40.14	13.70	40.84	14.40	
48	37.57	10.87	43.32	13.60	44.12	13.71	44.59	13.74	45.54	13.79	45.78	13.75	46.69	14.59	
110%	-5	29.71	4.24	35.43	5.28	41.14	6.30	44.00	6.77	46.86	7.28	50.43	7.56	51.57	7.79
	-2	29.71	4.32	35.43	5.35	41.14	6.36	44.00	6.83	46.86	7.34	50.43	7.64	51.57	7.84
	0	29.71	4.37	35.43	5.38	41.14	6.41	44.00	6.88	46.86	7.42	50.43	7.71	51.57	7.93
	2	29.71	4.46	35.43	5.43	41.14	6.51	44.00	6.95	46.86	7.50	50.43	7.82	51.57	8.03
	4	29.71	4.55	35.43	5.49	41.14	6.57	44.00	7.04	46.86	7.61	50.43	7.93	51.57	8.10

	6	29.71	4.60	35.43	5.56	41.14	6.63	44.00	7.15	46.86	7.70	50.43	8.01	51.57	8.23
	8	29.71	4.64	35.43	5.65	41.14	6.71	44.00	7.22	46.86	7.79	50.43	8.07	51.57	8.31
	10	29.71	4.69	35.43	5.72	41.14	6.80	44.00	7.35	46.86	7.91	50.43	8.13	51.57	8.39
	12	29.71	4.79	35.43	5.84	41.14	6.93	44.00	7.50	46.86	8.06	49.86	8.24	50.86	8.50
	14	29.71	4.88	35.43	5.94	41.14	7.07	44.00	7.63	46.86	8.21	49.14	8.31	50.29	8.56
	16	29.71	4.96	35.43	6.05	41.14	7.20	44.00	7.78	46.86	8.38	48.57	8.41	49.57	8.65
	18	29.71	5.06	35.43	6.17	41.14	7.35	44.00	8.00	46.86	8.78	47.86	8.84	49.00	8.92
	20	29.71	5.16	35.43	6.30	41.14	7.78	44.00	8.59	46.14	9.21	47.29	9.27	48.29	9.36
	21	29.71	5.21	35.43	6.49	41.14	8.06	44.00	8.91	45.86	9.42	46.86	9.49	48.00	9.57
	23	29.71	5.46	35.43	6.95	41.14	8.64	44.00	9.56	45.15	9.84	46.29	9.93	47.29	10.02
	25	29.71	5.82	35.43	7.43	41.14	9.24	44.00	10.24	44.57	10.27	45.57	10.37	46.71	10.45
	27	29.71	6.20	35.43	7.95	41.14	9.89	43.29	10.67	43.86	10.70	45.00	10.80	46.00	10.90
	29	29.71	6.62	35.43	8.48	41.14	10.57	42.72	11.10	43.29	11.15	44.29	11.25	45.43	11.35
	31	29.71	7.05	35.43	9.04	41.14	11.28	42.00	11.53	42.57	11.58	43.72	11.68	44.71	11.79
	33	29.71	7.50	35.43	9.64	40.86	11.89	41.43	11.96	42.00	12.01	43.00	12.13	44.14	12.24
	35	29.71	7.98	35.43	10.27	40.15	12.32	40.72	12.39	41.29	12.46	42.29	12.57	43.43	12.69
	37	29.71	8.49	35.43	10.93	39.57	12.77	40.15	12.82	40.57	12.89	41.72	13.02	42.72	13.14
	39	29.71	9.02	35.43	11.65	38.86	13.20	39.43	13.27	40.00	13.34	41.00	13.47	42.15	13.60
	41	29.71	9.12	35.43	11.74	38.55	13.30	39.12	13.36	39.70	13.43	40.48	13.56	40.88	13.70
	43	29.71	9.21	35.43	11.89	38.25	13.39	38.82	13.46	39.39	13.52	40.12	13.61	40.25	13.97
	45	29.71	9.51	35.43	11.96	37.86	13.51	38.41	13.62	39.04	13.65	39.71	13.98	39.87	14.30
	48	32.54	9.84	38.80	12.97	40.86	13.61	41.40	13.72	42.27	13.79	42.78	14.04	43.11	14.45
100%	-5	27.00	3.86	32.14	4.65	37.43	5.54	40.00	5.93	42.57	6.44	47.86	7.34	50.57	7.66
	-2	27.00	3.91	32.14	4.71	37.43	5.60	40.00	6.04	42.57	6.52	47.86	7.42	50.57	7.70
	0	27.00	3.95	32.14	4.76	37.43	5.66	40.00	6.12	42.57	6.58	47.86	7.54	50.57	7.79
	2	27.00	4.03	32.14	4.83	37.43	5.72	40.00	6.20	42.57	6.66	47.86	7.66	50.57	7.91
	4	27.00	4.06	32.14	4.87	37.43	5.81	40.00	6.29	42.57	6.74	47.86	7.73	50.57	8.00
	6	27.00	4.12	32.14	4.97	37.43	5.88	40.00	6.40	42.57	6.84	47.86	7.84	50.57	8.12
	8	27.00	4.20	32.14	5.05	37.43	5.99	40.00	6.47	42.57	6.95	47.86	7.96	50.57	8.26
	10	27.00	4.25	32.14	5.14	37.43	6.09	40.00	6.58	42.57	7.08	47.86	8.09	50.57	8.38
	12	27.00	4.31	32.14	5.24	37.43	6.20	40.00	6.70	42.57	7.22	47.86	8.24	49.86	8.44
	14	27.00	4.40	32.14	5.34	37.43	6.32	40.00	6.83	42.57	7.35	47.86	8.41	49.28	8.54
	16	27.00	4.48	32.14	5.44	37.43	6.45	40.00	6.97	42.57	7.50	47.57	8.51	48.57	8.64
	18	27.00	4.56	32.14	5.54	37.43	6.57	40.00	7.10	42.57	7.65	47.00	8.79	48.00	8.86
	20	27.00	4.65	32.14	5.66	37.43	6.77	40.00	7.46	42.57	8.19	46.28	9.21	47.28	9.29
	21	27.00	4.69	32.14	5.71	37.43	7.02	40.00	7.73	42.57	8.48	46.00	9.42	47.00	9.50
	23	27.00	4.81	32.14	6.09	37.43	7.51	40.00	8.28	42.57	9.09	45.43	9.85	46.28	9.94
	25	27.00	5.13	32.14	6.50	37.43	8.04	40.00	8.87	42.57	9.74	44.72	10.28	45.71	10.37
	27	27.00	5.47	32.14	6.93	37.43	8.59	40.00	9.49	42.57	10.42	44.00	10.72	45.00	10.82
	29	27.00	5.82	32.14	7.40	37.43	9.17	40.00	10.14	42.43	11.06	43.43	11.16	44.43	11.25
	31	27.00	6.20	32.14	7.90	37.43	9.79	40.00	10.82	41.86	11.50	42.72	11.59	43.71	11.69
	33	27.00	6.58	32.14	8.41	37.43	10.43	40.00	11.54	41.14	11.93	42.14	12.03	43.14	12.14
35	27.00	7.00	32.14	8.94	37.43	11.13	40.00	12.31	40.43	12.36	41.43	12.47	42.43	12.57	
37	27.00	7.45	32.14	9.52	37.43	11.86	39.28	12.74	39.86	12.81	40.86	12.92	41.72	13.02	
39	27.00	7.91	32.14	10.12	37.43	12.62	38.71	13.17	39.14	13.24	40.14	13.35	41.14	13.49	
41	27.00	8.28	32.14	10.49	37.43	13.08	38.11	13.26	38.84	13.44	39.45	13.67	40.54	13.76	
43	27.00	8.65	32.14	10.86	37.43	13.33	37.51	13.42	38.56	13.57	39.68	13.76	39.83	13.92	
45	27.00	9.14	32.14	11.35	37.43	13.55	36.71	13.60	38.36	13.82	39.34	13.97	39.03	14.10	
48	27.96	9.54	33.29	11.75	38.76	13.58	36.46	13.76	39.67	14.06	38.26	14.11	39.54	14.23	
90%	-5	24.29	3.42	29.00	4.10	33.71	4.84	36.00	5.28	38.29	5.62	43.00	6.46	47.71	7.39
	-2	24.29	3.45	29.00	4.14	33.71	4.90	36.00	5.35	38.29	5.68	43.00	6.52	47.71	7.47
	0	24.29	3.50	29.00	4.20	33.71	4.97	36.00	5.42	38.29	5.76	43.00	6.59	47.71	7.52
	2	24.29	3.55	29.00	4.25	33.71	5.03	36.00	5.50	38.29	5.85	43.00	6.73	47.71	7.63
	4	24.29	3.61	29.00	4.31	33.71	5.11	36.00	5.57	38.29	5.92	43.00	6.84	47.71	7.75
	6	24.29	3.66	29.00	4.40	33.71	5.21	36.00	5.68	38.29	6.02	43.00	6.94	47.71	7.88
	8	24.29	3.73	29.00	4.48	33.71	5.31	36.00	5.75	38.29	6.13	43.00	7.07	47.71	7.95
	10	24.29	3.80	29.00	4.58	33.71	5.41	36.00	5.84	38.29	6.27	43.00	7.16	47.71	8.08
	12	24.29	3.86	29.00	4.66	33.71	5.51	36.00	5.94	38.29	6.39	43.00	7.30	47.71	8.23
	14	24.29	3.93	29.00	4.74	33.71	5.61	36.00	6.05	38.29	6.50	43.00	7.43	47.71	8.38
	16	24.29	4.00	29.00	4.83	33.71	5.72	36.00	6.17	38.29	6.63	43.00	7.58	47.57	8.53
	18	24.29	4.06	29.00	4.93	33.71	5.82	36.00	6.29	38.29	6.77	43.00	7.73	47.00	8.79
	20	24.29	4.15	29.00	5.04	33.71	5.94	36.00	6.42	38.29	7.02	43.00	8.31	46.29	9.21
	21	24.29	4.18	29.00	5.07	33.71	6.04	36.00	6.63	38.29	7.27	43.00	8.61	46.00	9.42
	23	24.29	4.26	29.00	5.27	33.71	6.47	36.00	7.12	38.29	7.80	43.00	9.24	45.28	9.85
	25	24.29	4.49	29.00	5.64	33.71	6.92	36.00	7.61	38.29	8.33	43.00	9.89	44.72	10.28

	27	24.29	4.78	29.00	6.00	33.71	7.38	36.00	8.13	38.29	8.91	43.00	10.58	44.00	10.71
	29	24.29	5.09	29.00	6.40	33.71	7.88	36.00	8.67	38.29	9.52	42.57	11.06	43.43	11.15
	31	24.29	5.41	29.00	6.82	33.71	8.39	36.00	9.26	38.29	10.15	41.86	11.49	42.71	11.59
	33	24.29	5.74	29.00	7.25	33.71	8.96	36.00	9.87	38.29	10.83	41.28	11.94	42.14	12.02
	35	24.29	6.10	29.00	7.71	33.71	9.54	36.00	10.52	38.29	11.54	40.57	12.37	41.43	12.47
	37	24.29	6.47	29.00	8.19	33.71	10.15	36.00	11.20	38.29	12.31	39.86	12.81	40.86	12.90
	39	24.29	6.87	29.00	8.73	33.71	10.80	36.00	11.93	38.29	13.10	39.29	13.25	40.14	13.35
	41	24.29	7.10	29.00	9.12	33.71	11.19	36.00	12.24	38.29	13.18	39.01	13.59	39.87	13.67
	43	24.29	7.45	29.00	9.51	33.71	11.59	36.00	12.56	38.29	13.46	38.81	13.77	39.53	13.88
	45	24.29	7.92	29.00	9.99	33.71	12.06	36.00	12.98	38.29	13.84	38.60	13.91	38.93	14.07
	48	24.29	8.36	29.00	10.45	33.71	12.51	36.00	13.14	38.29	13.96	42.53	14.11	42.08	14.26
80%	-5	21.57	3.01	25.72	3.56	29.86	4.22	32.00	4.48	34.14	4.83	38.28	5.58	42.43	6.37
	-2	21.57	3.06	25.72	3.61	29.86	4.25	32.00	4.55	34.14	4.87	38.28	5.63	42.43	6.43
	0	21.57	3.11	25.72	3.65	29.86	4.31	32.00	4.61	34.14	4.96	38.28	5.71	42.43	6.52
	2	21.57	3.17	25.72	3.70	29.86	4.37	32.00	4.69	34.14	5.05	38.28	5.83	42.43	6.64
	4	21.57	3.22	25.72	3.76	29.86	4.45	32.00	4.80	34.14	5.14	38.28	5.93	42.43	6.73
	6	21.57	3.28	25.72	3.85	29.86	4.52	32.00	4.91	34.14	5.24	38.28	6.02	42.43	6.85
	8	21.57	3.34	25.72	3.94	29.86	4.62	32.00	4.99	34.14	5.35	38.28	6.11	42.43	6.98
	10	21.57	3.37	25.72	4.03	29.86	4.74	32.00	5.11	34.14	5.47	38.28	6.25	42.43	7.05
	12	21.57	3.42	25.72	4.10	29.86	4.83	32.00	5.21	34.14	5.59	38.28	6.37	42.43	7.18
	14	21.57	3.48	25.72	4.18	29.86	4.91	32.00	5.29	34.14	5.69	38.28	6.49	42.43	7.31
	16	21.57	3.53	25.72	4.25	29.86	5.01	32.00	5.39	34.14	5.79	38.28	6.62	42.43	7.45
	18	21.57	3.60	25.72	4.33	29.86	5.11	32.00	5.51	34.14	5.91	38.28	6.75	42.43	7.60
	20	21.57	3.67	25.72	4.41	29.86	5.21	32.00	5.61	34.14	6.02	38.28	7.00	42.43	8.13
	21	21.57	3.70	25.72	4.45	29.86	5.26	32.00	5.67	34.14	6.15	38.28	7.25	42.43	8.43
	23	21.57	3.77	25.72	4.55	29.86	5.51	32.00	6.04	34.14	6.59	38.28	7.76	42.43	9.04
	25	21.57	3.88	25.72	4.83	29.86	5.89	32.00	6.45	34.14	7.03	38.28	8.31	42.43	9.67
	27	21.57	4.13	25.72	5.14	29.86	6.27	32.00	6.88	34.14	7.51	38.28	8.87	42.43	10.35
	29	21.57	4.40	25.72	5.47	29.86	6.69	32.00	7.33	34.14	8.03	38.28	9.47	42.43	11.06
	31	21.57	4.66	25.72	5.82	29.86	7.12	32.00	7.81	34.14	8.56	38.28	10.12	41.72	11.50
	33	21.57	4.96	25.72	6.19	29.86	7.58	32.00	8.33	34.14	9.11	38.28	10.78	41.14	11.93
35	21.57	5.26	25.72	6.59	29.86	8.06	32.00	8.86	34.14	9.70	38.28	11.50	40.43	12.36	
37	21.57	5.57	25.72	6.98	29.86	8.58	32.00	9.44	34.14	10.33	38.28	12.26	39.86	12.79	
39	21.57	5.91	25.72	7.45	29.86	9.12	32.00	10.04	34.14	11.00	38.28	13.06	39.14	13.24	
41	21.57	6.04	25.72	7.51	29.86	9.26	32.00	10.30	34.14	11.20	38.28	13.39	38.90	13.47	
43	21.57	6.22	25.72	7.58	29.86	9.39	32.00	10.48	34.14	11.35	38.28	13.54	38.66	13.61	
45	21.57	6.39	25.72	7.67	29.86	9.57	32.00	10.70	34.14	11.55	38.28	13.69	38.18	13.84	
48	21.57	6.60	25.72	7.72	33.59	9.72	32.00	10.85	34.14	11.65	38.28	13.83	42.60	14.03	
70%	-5	18.86	2.69	22.57	3.15	26.14	3.57	28.00	3.83	29.86	4.09	33.43	4.68	37.14	5.38
	-2	18.86	2.71	22.57	3.17	26.14	3.59	28.00	3.90	29.86	4.16	33.43	4.75	37.14	5.45
	0	18.86	2.73	22.57	3.21	26.14	3.67	28.00	3.98	29.86	4.23	33.43	4.85	37.14	5.52
	2	18.86	2.74	22.57	3.23	26.14	3.73	28.00	4.05	29.86	4.31	33.43	4.95	37.14	5.61
	4	18.86	2.78	22.57	3.31	26.14	3.81	28.00	4.12	29.86	4.40	33.43	5.03	37.14	5.74
	6	18.86	2.82	22.57	3.36	26.14	3.90	28.00	4.26	29.86	4.51	33.43	5.12	37.14	5.86
	8	18.86	2.87	22.57	3.46	26.14	3.99	28.00	4.32	29.86	4.60	33.43	5.27	37.14	5.97
	10	18.86	2.93	22.57	3.52	26.14	4.10	28.00	4.41	29.86	4.73	33.43	5.37	37.14	6.04
	12	18.86	3.00	22.57	3.57	26.14	4.18	28.00	4.50	29.86	4.81	33.43	5.47	37.14	6.15
	14	18.86	3.05	22.57	3.63	26.14	4.25	28.00	4.56	29.86	4.89	33.43	5.57	37.14	6.27
	16	18.86	3.10	22.57	3.70	26.14	4.33	28.00	4.66	29.86	4.99	33.43	5.67	37.14	6.39
	18	18.86	3.15	22.57	3.77	26.14	4.41	28.00	4.74	29.86	5.08	33.43	5.79	37.14	6.52
	20	18.86	3.20	22.57	3.83	26.14	4.50	28.00	4.83	29.86	5.18	33.43	5.91	37.14	6.70
	21	18.86	3.23	22.57	3.87	26.14	4.53	28.00	4.88	29.86	5.23	33.43	5.99	37.14	6.93
	23	18.86	3.28	22.57	3.93	26.14	4.63	28.00	5.04	29.86	5.49	33.43	6.42	37.14	7.43
	25	18.86	3.35	22.57	4.10	26.14	4.93	28.00	5.39	29.86	5.86	33.43	6.87	37.14	7.95
	27	18.86	3.55	22.57	4.36	26.14	5.26	28.00	5.74	29.86	6.25	33.43	7.33	37.14	8.49
	29	18.86	3.77	22.57	4.63	26.14	5.59	28.00	6.12	29.86	6.65	33.43	7.81	37.14	9.07
	31	18.86	3.98	22.57	4.91	26.14	5.96	28.00	6.50	29.86	7.08	33.43	8.33	37.14	9.67
	33	18.86	4.23	22.57	5.23	26.14	6.34	28.00	6.92	29.86	7.55	33.43	8.87	37.14	10.32
35	18.86	4.48	22.57	5.54	26.14	6.72	28.00	7.37	29.86	8.03	33.43	9.46	37.14	11.00	
37	18.86	4.73	22.57	5.87	26.14	7.15	28.00	7.81	29.86	8.54	33.43	10.07	37.14	11.71	
39	18.86	5.01	22.57	6.22	26.14	7.58	28.00	8.31	29.86	9.07	33.43	10.70	37.14	12.47	
41	18.86	5.23	22.57	6.44	26.14	7.80	28.00	8.59	29.86	9.35	33.43	11.14	37.14	13.03	
43	18.86	5.66	22.57	6.88	26.14	8.12	28.00	9.05	29.86	9.63	33.43	11.55	37.14	13.43	
45	18.86	5.78	22.57	7.03	26.14	8.29	28.00	9.19	29.86	10.10	33.43	12.17	37.14	13.95	
48	18.86	5.93	22.57	7.09	26.14	8.38	28.00	9.34	29.86	10.38	33.43	12.72	37.14	14.28	

60%	-5	16.14	2.29	19.29	2.66	22.43	3.10	24.00	3.30	25.57	3.57	28.71	4.00	31.86	4.59
	-2	16.14	2.31	19.29	2.70	22.43	3.16	24.00	3.35	25.57	3.60	28.71	4.06	31.86	4.62
	0	16.14	2.34	19.29	2.73	22.43	3.20	24.00	3.39	25.57	3.66	28.71	4.12	31.86	4.68
	2	16.14	2.38	19.29	2.80	22.43	3.26	24.00	3.46	25.57	3.71	28.71	4.21	31.86	4.74
	4	16.14	2.45	19.29	2.85	22.43	3.32	24.00	3.50	25.57	3.77	28.71	4.27	31.86	4.81
	6	16.14	2.47	19.29	2.91	22.43	3.38	24.00	3.58	25.57	3.84	28.71	4.36	31.86	4.92
	8	16.14	2.52	19.29	2.95	22.43	3.45	24.00	3.64	25.57	3.92	28.71	4.44	31.86	5.00
	10	16.14	2.57	19.29	3.02	22.43	3.50	24.00	3.75	25.57	4.00	28.71	4.53	31.86	5.08
	12	16.14	2.62	19.29	3.07	22.43	3.57	24.00	3.81	25.57	4.06	28.71	4.61	31.86	5.16
	14	16.14	2.65	19.29	3.12	22.43	3.62	24.00	3.88	25.57	4.15	28.71	4.69	31.86	5.26
	16	16.14	2.69	19.29	3.17	22.43	3.68	24.00	3.95	25.57	4.21	28.71	4.78	31.86	5.36
	18	16.14	2.74	19.29	3.22	22.43	3.75	24.00	4.01	25.57	4.30	28.71	4.86	31.86	5.46
	20	16.14	2.77	19.29	3.28	22.43	3.81	24.00	4.10	25.57	4.38	28.71	4.96	31.86	5.57
	21	16.14	2.80	19.29	3.30	22.43	3.85	24.00	4.13	25.57	4.41	28.71	5.01	31.86	5.62
	23	16.14	2.84	19.29	3.37	22.43	3.91	24.00	4.21	25.57	4.49	28.71	5.21	31.86	5.99
	25	16.14	2.89	19.29	3.42	22.43	4.06	24.00	4.41	25.57	4.78	28.71	5.56	31.86	6.39
	27	16.14	3.00	19.29	3.63	22.43	4.33	24.00	4.71	25.57	5.09	28.71	5.92	31.86	6.82
	29	16.14	3.17	19.29	3.85	22.43	4.61	24.00	5.01	25.57	5.42	28.71	6.32	31.86	7.28
	31	16.14	3.37	19.29	4.08	22.43	4.89	24.00	5.32	25.57	5.77	28.71	6.72	31.86	7.74
	33	16.14	3.55	19.29	4.33	22.43	5.19	24.00	5.66	25.57	6.14	28.71	7.15	31.86	8.26
35	16.14	3.77	19.29	4.59	22.43	5.51	24.00	6.00	25.57	6.52	28.71	7.61	31.86	8.79	
37	16.14	3.98	19.29	4.86	22.43	5.84	24.00	6.37	25.57	6.92	28.71	8.09	31.86	9.35	
39	16.14	4.20	19.29	5.14	22.43	6.19	24.00	6.75	25.57	7.35	28.71	8.59	31.86	9.95	
41	16.14	4.33	19.29	5.36	22.43	6.41	24.00	7.02	25.57	7.62	28.71	9.00	31.86	10.40	
43	16.14	4.47	19.29	5.59	22.43	6.64	24.00	7.23	25.57	7.88	28.71	9.38	31.86	10.85	
45	16.14	4.68	19.29	5.87	22.43	6.91	24.00	7.50	25.57	8.27	28.71	9.80	31.86	11.45	
48	16.14	4.85	19.29	6.13	22.43	7.14	24.00	7.70	25.57	8.59	28.71	10.16	31.86	11.99	
50%	-5	13.50	1.99	16.14	2.30	18.71	2.65	20.00	2.77	21.29	2.92	23.86	3.32	26.57	3.58
	-2	13.50	2.01	16.14	2.35	18.71	2.67	20.00	2.81	21.29	2.98	23.86	3.37	26.57	3.63
	0	13.50	2.04	16.14	2.39	18.71	2.72	20.00	2.85	21.29	3.01	23.86	3.42	26.57	3.69
	2	13.50	2.07	16.14	2.42	18.71	2.77	20.00	2.89	21.29	3.06	23.86	3.44	26.57	3.76
	4	13.50	2.09	16.14	2.46	18.71	2.80	20.00	2.92	21.29	3.12	23.86	3.53	26.57	3.86
	6	13.50	2.13	16.14	2.50	18.71	2.84	20.00	2.99	21.29	3.18	23.86	3.58	26.57	3.97
	8	13.50	2.18	16.14	2.54	18.71	2.89	20.00	3.06	21.29	3.22	23.86	3.64	26.57	4.10
	10	13.50	2.22	16.14	2.57	18.71	2.94	20.00	3.10	21.29	3.32	23.86	3.73	26.57	4.16
	12	13.50	2.24	16.14	2.60	18.71	2.99	20.00	3.17	21.29	3.38	23.86	3.80	26.57	4.23
	14	13.50	2.27	16.14	2.64	18.71	3.02	20.00	3.23	21.29	3.43	23.86	3.86	26.57	4.31
	16	13.50	2.31	16.14	2.67	18.71	3.07	20.00	3.28	21.29	3.48	23.86	3.93	26.57	4.38
	18	13.50	2.34	16.14	2.72	18.71	3.12	20.00	3.33	21.29	3.55	23.86	4.00	26.57	4.46
	20	13.50	2.37	16.14	2.75	18.71	3.17	20.00	3.38	21.29	3.62	23.86	4.06	26.57	4.54
	21	13.50	2.39	16.14	2.79	18.71	3.20	20.00	3.42	21.29	3.65	23.86	4.11	26.57	4.59
	23	13.50	2.42	16.14	2.82	18.71	3.25	20.00	3.48	21.29	3.72	23.86	4.18	26.57	4.69
	25	13.50	2.45	16.14	2.87	18.71	3.32	20.00	3.55	21.29	3.83	23.86	4.40	26.57	5.01
	27	13.50	2.50	16.14	2.99	18.71	3.50	20.00	3.78	21.29	4.06	23.86	4.68	26.57	5.34
	29	13.50	2.64	16.14	3.15	18.71	3.72	20.00	4.01	21.29	4.33	23.86	4.98	26.57	5.69
	31	13.50	2.79	16.14	3.33	18.71	3.93	20.00	4.26	21.29	4.59	23.86	5.29	26.57	6.05
	33	13.50	2.95	16.14	3.53	18.71	4.18	20.00	4.51	21.29	4.88	23.86	5.62	26.57	6.44
35	13.50	3.12	16.14	3.73	18.71	4.41	20.00	4.78	21.29	5.16	23.86	5.97	26.57	6.83	
37	13.50	3.28	16.14	3.95	18.71	4.68	20.00	5.06	21.29	5.47	23.86	6.34	26.57	7.26	
39	13.50	3.47	16.14	4.16	18.71	4.94	20.00	5.36	21.29	5.81	23.86	6.72	26.57	7.71	
41	13.50	3.61	16.14	4.34	18.71	5.12	20.00	5.61	21.29	6.06	23.86	7.08	26.57	8.07	
43	13.50	3.85	16.14	4.64	18.71	5.30	20.00	5.86	21.29	6.21	23.86	7.43	26.57	8.43	
45	13.50	3.94	16.14	4.76	18.71	5.66	20.00	6.31	21.29	6.47	23.86	8.15	26.57	9.15	
48	13.50	4.03	16.14	4.89	18.71	5.99	20.00	6.71	21.29	6.76	23.86	8.81	26.57	9.84	

14HP heating mode

Combination (Capacity index)	Outdoor air temp.		Indoor temperature(°C DB)											
			16		18		20		21		22		24	
	°C DB	°C WB	Tc	PI	Tc	PI	Tc	PI	Tc	PI	Tc	PI	Tc	PI
130%	-19.8	-20	29.14	7.91	29.00	8.46	28.86	9.02	28.86	9.30	28.72	9.58	28.72	10.14
	-18.8	-19	29.57	8.08	29.43	8.63	29.43	9.18	29.29	9.46	29.29	9.72	29.14	10.27
	-16.7	-17	30.71	8.46	30.57	8.98	30.43	9.52	30.43	9.78	30.43	10.04	30.29	10.57
	-13.7	-15	32.00	8.85	31.86	9.36	31.71	9.87	31.71	10.11	31.57	10.38	31.57	10.89
	-11.8	-13	33.29	9.24	33.29	9.74	33.14	10.22	33.00	10.46	33.00	10.71	32.86	11.19
	-9.8	-11	34.86	9.65	34.71	10.11	34.57	10.58	34.57	10.81	34.57	11.04	34.43	11.51
	-9.5	-10	35.71	9.85	35.57	10.30	35.43	10.75	35.43	10.99	35.28	11.20	35.28	11.65
	-8.5	-9.1	36.43	10.03	36.29	10.46	36.29	10.91	36.14	11.13	36.14	11.35	36.00	11.80
	-7	-7.6	37.71	10.32	37.71	10.75	37.57	11.18	37.57	11.39	37.43	11.60	37.28	12.03
	-5	-5.6	39.71	10.71	39.57	11.12	39.43	11.52	39.43	11.73	39.29	11.92	39.29	12.32
	-3	-3.7	41.57	11.06	41.43	11.45	41.43	11.83	41.28	12.03	41.28	12.22	41.14	12.60
	0	-0.7	44.85	11.60	44.85	11.96	44.71	12.31	44.71	12.44	44.57	12.67	44.57	13.02
	3	2.2	48.42	12.08	48.29	12.41	48.14	12.75	48.14	12.90	48.14	13.08	48.00	13.40
	5	4.1	50.85	12.38	50.71	12.70	50.71	13.01	50.57	13.17	50.57	13.33	50.43	13.63
	7	6	53.43	12.67	53.28	12.96	53.28	13.27	53.14	13.41	53.14	13.56	51.00	13.02
	9	7.9	56.14	12.93	56.00	13.22	56.00	13.50	55.86	13.65	54.71	13.36	51.00	12.24
	11	9.8	59.00	13.20	58.86	13.46	58.57	13.63	56.57	13.09	54.71	12.56	51.00	11.52
13	11.8	62.14	13.44	62.00	13.70	58.57	12.77	56.57	12.26	54.71	11.79	51.00	10.81	
15	13.7	65.14	13.68	62.28	12.98	58.57	12.03	56.57	11.57	54.71	11.10	51.00	10.20	
120%	-19.8	-20	29.00	8.66	28.86	9.17	28.71	9.69	28.71	9.94	28.71	10.20	28.57	10.72
	-18.8	-19	29.43	8.82	29.29	9.33	29.29	9.84	29.14	10.09	29.14	10.35	29.00	10.86
	-16.7	-17	30.57	9.17	30.43	9.66	30.24	10.14	30.29	10.39	30.29	10.64	30.14	11.12
	-13.7	-15	31.86	9.53	31.72	10.00	31.57	10.46	31.57	10.71	31.57	10.94	31.43	11.41
	-11.8	-13	33.15	9.90	33.15	10.35	33.00	10.80	33.00	11.03	32.86	11.25	32.86	11.70
	-9.8	-11	34.71	10.27	34.57	10.70	34.57	11.13	34.43	11.35	34.43	11.55	34.29	11.99
	-9.5	-10	35.58	10.46	35.43	10.89	35.29	11.29	35.29	11.51	35.29	11.71	35.14	12.13
	-8.5	-9.1	36.29	10.62	36.14	11.03	36.14	11.44	36.00	11.64	36.00	11.86	35.86	12.26
	-7	-7.6	37.57	10.90	37.57	11.29	37.43	11.68	37.43	11.89	37.29	12.08	37.29	12.47
	-5	-5.6	39.57	11.25	39.43	11.63	39.28	12.00	39.28	12.19	39.28	12.38	39.15	12.75
	-3	-3.7	41.43	11.58	41.43	11.95	41.29	12.29	41.29	12.47	41.14	12.66	41.14	13.01
	0	-0.7	44.72	12.08	44.72	12.41	44.57	12.73	44.57	12.91	44.43	13.06	44.43	13.40
	3	2.2	48.29	12.53	48.14	12.83	48.14	13.14	48.00	13.30	48.00	13.44	47.00	13.37
	5	4.1	50.72	12.80	50.57	13.09	50.57	13.38	50.43	13.53	50.43	13.68	47.00	12.56
	7	6	53.29	13.06	53.29	13.34	53.15	13.62	52.29	13.43	50.57	12.88	47.00	11.82
	9	7.9	56.00	13.33	55.86	13.59	54.00	13.14	52.29	12.62	50.57	12.11	47.00	11.12
	11	9.8	58.86	13.56	57.43	13.33	54.00	12.35	52.29	11.87	50.57	11.39	47.00	10.48
13	11.8	61.00	13.43	57.43	12.50	54.00	11.58	52.29	11.15	50.57	10.71	47.00	9.85	
15	13.7	61.00	12.64	57.43	11.77	54.00	10.93	52.29	10.51	50.57	10.10	47.00	9.30	
110%	-19.8	-20	28.86	9.42	28.72	9.88	28.57	10.36	28.57	10.60	28.58	10.83	28.43	11.31
	-18.8	-19	29.29	9.56	29.14	10.03	29.14	10.49	29.14	10.73	29.00	10.96	29.00	11.42
	-16.7	-17	30.43	9.88	30.29	10.33	30.71	10.78	30.14	11.00	30.14	11.23	30.00	11.67
	-13.7	-15	31.72	10.22	31.58	10.65	31.43	11.07	31.43	11.29	31.43	11.51	31.28	11.93
	-11.8	-13	33.00	10.56	33.00	10.97	32.86	11.38	32.86	11.58	32.71	11.79	32.71	12.21
	-9.8	-11	34.57	10.90	34.43	11.29	34.43	11.68	34.28	11.89	34.28	12.08	34.28	12.47
	-9.5	-10	35.43	11.07	35.29	11.45	35.14	11.84	35.14	12.03	35.14	12.22	35.00	12.60
	-8.5	-9.1	36.14	11.22	36.00	11.60	36.00	11.97	35.86	12.16	35.86	12.35	35.86	11.26
	-7	-7.6	37.43	11.48	37.43	11.83	37.29	12.19	37.29	12.38	37.29	12.56	37.14	12.92
	-5	-5.6	39.43	11.80	39.29	12.15	39.14	12.48	39.14	12.66	39.14	12.83	39.00	13.18
	-3	-3.7	41.29	12.11	41.29	12.43	41.14	12.76	41.14	12.92	41.00	13.08	41.00	13.41
	0	-0.7	44.57	12.56	44.57	12.86	44.43	13.17	44.43	13.31	44.43	13.47	43.14	13.21
	3	2.2	48.14	12.98	48.00	13.25	48.00	13.53	47.86	13.66	46.29	13.11	43.14	12.02
	5	4.1	50.57	13.22	50.57	13.50	49.57	13.37	47.86	12.83	46.29	12.32	43.14	11.31
	7	6	53.14	13.47	52.71	13.56	49.57	12.56	47.86	12.06	46.29	11.58	43.14	10.64
	9	7.9	55.86	13.69	52.71	12.74	49.57	11.81	47.86	11.35	46.29	10.90	43.14	10.03
	11	9.8	55.86	12.88	52.71	11.99	49.57	11.12	47.86	10.70	46.29	10.27	43.14	9.46
13	11.8	55.86	12.08	52.71	11.25	49.57	10.45	47.86	10.06	46.29	9.66	43.14	8.91	
15	13.7	55.86	10.73	52.71	10.61	49.57	9.87	47.86	9.49	46.29	9.14	43.14	8.43	
100%	-19.8	-20	28.71	10.17	28.57	10.59	28.57	11.03	28.43	11.25	28.43	11.45	28.29	11.89
	-18.8	-19	29.14	10.30	29.14	10.72	29.00	11.15	29.00	11.36	28.86	11.58	28.86	12.00

	-16.7	-17	30.29	10.59	30.14	11.00	30.14	11.41	30.00	11.61	30.00	11.81	30.00	12.22
	-13.7	-15	31.57	10.90	31.43	11.29	31.28	11.68	31.28	11.89	31.28	12.08	31.14	12.47
	-11.8	-13	32.86	11.22	32.86	11.58	32.72	11.96	32.72	12.15	32.72	12.34	32.57	12.72
	-9.8	-11	34.43	11.52	34.29	11.89	34.29	12.24	34.29	12.43	34.14	12.60	34.14	12.95
	-9.5	-10	35.28	11.68	35.15	12.03	35.15	12.38	35.00	12.56	35.00	12.73	34.86	13.08
	-8.5	-9.1	36.00	11.81	35.86	12.16	35.86	12.50	35.86	12.67	35.72	12.85	35.72	13.18
	-7	-7.6	37.29	12.05	37.29	12.38	37.14	12.70	37.14	12.88	37.14	13.04	37.00	13.37
	-5	-5.6	39.29	12.35	39.14	12.66	39.14	12.98	39.00	13.12	39.00	13.28	38.86	13.60
	-3	-3.7	41.14	12.63	41.14	11.47	41.00	13.22	41.00	13.37	41.00	13.52	39.29	12.95
	0	-0.7	44.43	13.04	44.43	13.31	44.28	13.59	43.57	13.37	42.14	12.82	39.29	11.76
	3	2.2	48.00	13.41	47.86	13.66	45.00	12.64	43.57	12.15	42.14	11.67	39.29	10.71
	5	4.1	50.43	13.66	47.86	12.83	45.00	11.89	43.57	11.44	42.14	10.99	39.29	10.10
	7	6	50.72	12.96	47.86	12.06	45.00	11.19	43.57	10.77	42.14	10.35	39.29	9.52
	9	7.9	50.72	12.18	47.86	11.35	45.00	10.54	43.57	10.01	42.14	9.75	39.29	8.98
	11	9.8	50.72	11.47	47.86	10.70	45.00	9.94	43.57	9.56	42.14	9.20	39.29	8.49
	13	11.8	50.72	10.77	47.86	10.06	45.00	9.36	43.57	9.01	42.14	8.68	39.29	8.01
	15	13.7	50.72	10.16	47.86	9.49	45.00	8.84	43.57	8.52	42.14	8.20	39.29	7.59
90%	-19.8	-20	28.52	10.93	28.38	11.31	28.38	11.70	28.24	11.89	28.24	12.09	28.24	12.47
	-18.8	-19	28.95	11.04	28.95	11.44	28.81	11.81	28.81	12.00	28.81	12.19	28.66	12.57
	-16.7	-17	30.09	11.32	29.95	11.68	29.95	12.05	29.95	12.24	29.80	12.41	29.80	12.77
	-13.7	-15	31.37	11.60	31.23	11.95	31.23	12.29	31.09	12.47	31.09	12.64	31.09	12.99
	-11.8	-13	32.66	11.87	32.66	12.21	32.51	12.54	32.51	12.72	32.51	12.88	32.37	13.21
	-9.8	-11	34.23	12.15	34.23	12.47	34.08	12.79	34.08	12.95	34.08	13.12	33.94	13.44
	-9.5	-10	35.08	12.29	34.94	12.61	34.94	12.92	34.80	13.08	34.80	13.24	34.80	13.54
	-8.5	-9.1	35.79	12.43	35.79	12.73	35.65	13.04	35.65	13.18	35.65	13.34	35.22	13.47
	-7	-7.6	37.08	12.63	37.08	12.92	36.94	13.22	36.94	13.37	36.94	13.51	35.22	12.86
	-5	-5.6	39.07	12.90	38.93	13.18	38.93	13.46	38.79	13.60	37.79	13.18	35.22	12.09
	-3	-3.7	40.93	13.15	40.93	13.41	40.50	13.47	39.07	12.93	37.79	12.41	35.22	11.39
	0	-0.7	44.35	13.53	43.07	13.20	40.50	12.22	39.07	11.74	37.79	11.28	35.22	10.36
	3	2.2	45.64	12.89	43.07	12.00	40.50	11.13	39.07	10.71	37.79	10.29	35.22	9.47
	5	4.1	45.64	12.12	43.07	11.29	40.50	10.49	39.07	10.09	37.79	9.71	35.22	8.94
	7	6	45.64	11.39	43.07	10.64	40.50	9.88	39.07	9.52	37.79	9.16	35.22	8.44
80%	9	7.9	45.64	10.74	43.07	10.01	40.50	9.31	39.07	8.98	37.79	8.65	35.22	7.98
	11	9.8	45.64	10.11	43.07	9.45	40.50	8.81	39.07	8.49	37.79	8.17	35.22	7.56
	13	11.8	45.64	9.52	43.07	8.91	40.50	8.30	39.07	8.01	37.79	7.72	35.22	7.14
	15	13.7	45.64	9.00	43.07	8.41	40.50	7.86	39.07	7.59	37.79	7.31	35.22	6.77
	-19.8	-20	28.43	11.68	28.29	12.02	28.29	12.37	28.29	12.54	28.14	12.72	28.14	13.05
	-18.8	-19	28.86	11.79	28.86	12.13	28.71	12.47	28.71	12.64	28.71	12.80	28.57	13.15
	-16.7	-17	30.00	12.03	29.86	12.35	29.86	12.69	29.86	12.85	29.86	13.01	29.71	13.33
	-13.7	-15	31.28	12.28	31.14	12.58	31.14	12.90	31.14	13.05	31.00	13.21	31.00	13.53
	-11.8	-13	32.57	12.53	32.57	12.83	32.43	13.12	32.43	13.27	32.43	13.43	31.43	13.06
	-9.8	-11	34.14	12.77	34.14	13.06	34.00	13.35	34.00	13.49	33.71	13.46	31.43	12.34
	-9.5	-10	35.00	12.90	34.85	13.18	34.86	13.46	34.86	13.60	33.71	13.06	31.43	11.97
	-8.5	-9.1	35.72	13.02	33.20	13.30	35.57	13.56	34.86	13.25	33.71	12.72	31.43	11.65
	-7	-7.6	37.00	13.21	37.00	13.47	36.00	13.18	34.86	12.66	33.71	12.15	31.43	11.15
	-5	-5.6	39.00	13.44	38.29	13.37	36.00	12.38	34.86	11.90	33.71	11.42	31.43	10.49
	-3	-3.7	40.57	13.52	38.29	12.58	36.00	11.65	34.86	11.22	33.71	10.77	31.43	9.91
0	-0.7	40.57	12.27	38.29	11.42	36.00	10.61	34.86	10.22	33.71	9.81	31.43	9.04	
3	2.2	40.57	11.17	38.29	10.42	36.00	9.69	34.86	9.33	33.71	8.98	31.43	8.28	
5	4.1	40.57	10.52	38.29	9.82	36.00	9.14	34.86	8.81	33.71	8.49	31.43	7.83	
7	6	40.57	9.91	38.29	9.27	36.00	8.63	34.86	8.33	33.71	8.02	31.43	7.41	
9	7.9	40.57	9.36	38.29	8.75	36.00	8.15	34.86	7.86	33.71	7.59	31.43	7.02	
11	9.8	40.57	8.84	38.29	8.27	36.00	7.72	34.86	7.44	33.71	7.18	31.43	6.66	
13	11.8	40.57	8.33	38.29	7.80	36.00	7.29	34.86	7.03	33.71	6.79	31.43	6.29	
15	13.7	40.57	7.88	38.29	7.40	36.00	6.92	34.86	6.67	33.71	6.44	31.43	5.99	
70%	-19.8	-20	28.22	12.44	28.08	12.73	28.08	13.04	28.08	13.18	28.08	13.34	27.37	13.19
	-18.8	-19	28.65	12.54	28.65	12.83	28.51	13.12	28.51	13.27	28.51	13.43	27.37	12.92
	-16.7	-17	29.79	12.74	29.79	13.04	29.65	13.31	29.65	13.46	29.36	11.99	27.37	12.32
	-13.7	-15	31.07	12.96	30.93	13.24	30.93	13.51	30.36	13.31	29.36	12.77	27.37	11.71
	-11.8	-13	32.35	13.18	32.35	13.44	31.50	13.12	30.36	12.61	29.36	12.11	27.37	11.10
	-9.8	-11	33.92	13.40	33.49	13.38	31.50	12.40	30.36	11.92	29.36	11.44	27.37	10.51
	-9.5	-10	34.78	13.51	33.49	12.99	31.50	12.03	30.36	11.57	29.36	11.12	27.37	10.22
	-8.5	-9.1	35.49	13.59	33.49	12.64	31.50	11.71	30.36	11.26	29.36	10.83	27.37	9.95
-7	-7.6	35.49	12.98	33.49	12.08	31.50	11.20	30.36	10.78	29.36	10.36	27.37	9.53	

	-5	-5.6	35.49	12.19	33.49	11.36	31.50	10.55	30.36	10.14	29.36	11.98	27.37	9.00
	-3	-3.7	35.49	11.48	33.49	10.71	31.50	9.95	30.36	9.58	29.36	9.21	27.37	8.50
	0	-0.7	35.49	10.45	33.49	9.77	31.50	9.08	30.36	8.75	29.36	8.43	27.37	7.79
	3	2.2	35.49	9.55	33.49	8.94	31.50	8.33	30.36	8.02	29.36	7.73	27.37	7.15
	5	4.1	35.49	9.01	33.49	8.43	31.50	7.88	30.36	7.59	29.36	7.31	27.37	6.77
	7	6	35.49	8.52	33.49	7.98	31.50	7.44	30.36	7.18	29.36	6.93	27.37	6.42
	9	7.9	35.49	8.05	33.49	7.54	31.50	7.05	30.36	6.80	29.36	6.57	27.37	6.09
	11	9.8	35.49	7.61	33.49	7.14	31.50	6.68	30.36	6.45	29.36	6.23	27.37	5.78
	13	11.8	35.49	7.19	33.49	6.76	31.50	6.32	30.36	6.12	29.36	5.90	27.37	5.49
	15	13.7	35.49	6.82	33.49	6.41	31.50	6.00	30.36	5.81	29.36	5.61	27.37	5.23
60%	-19.8	-20	28.14	13.19	28.00	13.44	27.00	12.93	26.14	12.42	25.29	11.93	23.57	10.94
	-18.8	-19	28.57	13.28	28.57	13.53	27.00	12.66	26.14	12.16	25.29	11.67	23.57	10.71
	-16.7	-17	29.71	13.46	28.71	13.03	27.00	12.08	26.14	11.61	25.29	11.15	23.57	10.24
	-13.7	-15	30.43	13.31	28.71	12.38	27.00	11.48	26.14	11.04	25.29	10.61	23.57	9.75
	-11.8	-13	30.43	12.60	28.71	11.73	27.00	10.88	26.14	10.48	25.29	10.07	23.57	9.31
	-9.8	-11	30.43	11.90	28.71	11.09	27.00	10.30	26.14	9.91	25.29	9.53	23.57	8.79
	-9.5	-10	30.43	11.57	28.71	10.78	27.00	10.01	26.14	9.65	25.29	9.27	23.57	8.54
	-8.5	-9.1	30.43	11.26	28.71	10.51	27.00	9.77	26.14	9.40	25.29	9.04	23.57	8.34
	-7	-7.6	30.43	10.77	28.71	10.06	27.00	9.34	26.14	9.01	25.29	8.66	23.57	8.01
	-5	-5.6	30.43	10.14	28.71	9.47	27.00	8.82	26.14	8.50	25.29	8.18	23.57	7.57
	-3	-3.7	30.43	9.58	28.71	8.95	27.00	8.34	26.14	8.05	25.29	7.75	23.57	7.16
	0	-0.7	30.43	8.75	28.71	8.20	27.00	7.64	26.14	7.38	25.29	7.11	23.57	6.58
	3	2.2	30.43	8.02	28.71	7.53	27.00	7.03	26.14	6.79	25.29	6.55	23.57	6.07
	5	4.1	30.43	7.59	28.71	7.12	27.00	6.66	26.14	6.44	25.29	6.21	23.57	5.77
	7	6	30.43	7.18	28.71	6.74	27.00	6.31	26.14	6.10	25.29	5.90	23.57	5.48
9	7.9	30.43	6.80	28.71	6.39	27.00	5.99	26.14	5.80	25.29	5.59	23.57	5.22	
11	9.8	30.43	6.45	28.71	6.07	27.00	5.70	26.14	5.51	25.29	5.32	23.57	4.97	
13	11.8	30.43	6.10	28.71	5.75	27.00	5.41	26.14	5.23	25.29	5.06	23.57	4.72	
15	13.7	30.43	5.81	28.71	5.46	27.00	5.14	26.14	4.98	25.29	4.82	23.57	4.50	
50%	-19.8	-20	25.35	12.00	23.92	11.17	22.50	10.38	21.65	10.00	20.93	9.61	19.51	8.85
	-18.8	-19	25.35	11.74	23.92	10.94	22.50	10.17	21.65	9.78	20.93	9.40	19.51	8.68
	-16.7	-17	25.35	11.20	23.92	10.45	22.50	9.72	21.65	9.36	20.93	9.01	19.51	8.31
	-13.7	-15	25.35	10.67	23.92	9.95	22.50	9.26	21.65	8.92	20.93	8.59	19.51	7.93
	-11.8	-13	25.35	10.13	23.92	9.46	22.50	8.81	21.65	8.49	20.93	8.17	19.51	7.56
	-9.8	-11	25.35	9.59	23.92	8.97	22.50	8.36	21.65	8.05	20.93	7.76	19.51	7.18
	-9.5	-10	25.35	9.33	23.92	8.72	22.50	8.14	21.65	7.85	20.93	7.56	19.51	6.99
	-8.5	-9.1	25.35	9.10	23.92	8.52	22.50	7.93	21.65	7.66	20.93	7.38	19.51	6.83
	-7	-7.6	25.35	8.72	23.92	8.17	22.50	7.61	21.65	7.35	20.93	7.09	19.51	6.57
	-5	-5.6	25.35	8.23	23.92	7.72	22.50	7.21	21.65	6.96	20.93	6.71	19.51	6.22
	-3	-3.7	25.35	7.79	23.92	7.31	22.50	6.83	21.65	6.60	20.93	6.36	19.51	5.91
	0	-0.7	25.35	7.15	23.92	6.71	22.50	6.29	21.65	6.07	20.93	5.87	19.51	5.46
	3	2.2	25.35	6.58	23.92	6.19	22.50	5.80	21.65	5.61	20.93	5.42	19.51	5.06
	5	4.1	25.35	6.25	23.92	5.87	22.50	5.51	21.65	5.33	20.93	5.16	19.51	4.81
	7	6	25.35	5.93	23.92	5.58	22.50	5.25	21.65	5.07	20.93	4.91	19.51	4.59
9	7.9	25.35	5.62	23.92	5.30	22.50	4.98	21.65	4.84	20.93	4.68	19.51	4.37	
11	9.8	25.35	5.35	23.92	5.04	22.50	4.75	21.65	4.61	20.93	4.46	19.51	4.17	
13	11.8	25.35	5.09	23.92	4.80	22.50	4.52	21.65	4.39	20.93	4.24	19.51	3.98	
15	13.7	25.35	4.84	23.92	4.58	22.50	4.32	21.65	4.19	20.93	4.05	19.51	3.81	

Note:

1. [shaded] is shown as reference.
2. The above table shows the average value of conditions may operate.
3. It is recommended to connect less than 130%.

16HP cooling mode

Combination (%) (Capacity index)	Outdoor temperature (°C DB)	Indoor temperature(°C DB/WD)													
		DB:20.8,WB:14		DB:23.3,WB:16		DB:25.8,WB:18		DB:27,WB:19		DB:28.2,WB:20		DB:30.7,WB:22		DB:32,WB:24	
		TC	PI	TC	PI	TC	PI	TC	PI	TC	PI	TC	PI	TC	PI
130%	-5	39.54	5.73	47.09	6.99	54.64	7.50	56.73	7.80	59.46	8.02	60.91	8.73	62.44	8.78
	-2	39.54	5.73	47.09	7.13	54.64	7.50	56.73	7.85	59.46	8.02	60.91	8.84	62.44	8.87
	0	39.54	5.83	47.09	7.25	54.64	7.77	56.73	8.28	59.46	8.49	60.91	8.94	62.44	8.99
	2	39.54	5.93	47.09	7.27	54.64	8.04	56.73	8.75	59.46	8.59	60.91	9.01	62.44	9.12
	4	39.54	6.07	47.09	7.41	54.64	8.32	56.73	8.78	59.46	8.70	60.91	9.00	62.44	9.30
	6	39.54	6.18	47.09	7.56	54.64	8.62	56.73	8.86	58.80	8.97	60.16	9.00	61.75	9.36
	8	39.54	6.33	47.09	7.73	54.64	9.06	56.73	9.29	58.07	9.26	59.51	3.90	60.97	9.45
	10	39.54	6.46	47.09	7.90	54.64	9.39	56.73	9.60	57.37	4.04	58.82	4.06	60.27	9.73
	12	39.54	6.58	47.09	8.05	54.64	9.58	55.93	4.03	56.73	4.06	58.02	4.07	59.46	9.79
	14	39.54	6.71	47.09	8.20	54.48	4.05	55.29	4.06	55.93	4.08	57.37	4.09	58.82	10.01
	16	39.54	6.82	47.09	8.37	53.84	4.06	54.48	4.08	55.12	4.10	56.57	4.12	58.02	10.17
	18	39.54	6.95	47.09	8.54	53.04	10.01	53.68	10.07	54.48	10.13	55.93	10.22	57.37	10.32
	20	39.54	7.11	47.09	9.09	52.23	10.51	53.04	10.56	53.68	10.62	55.12	10.71	56.57	10.83
	21	39.54	7.29	47.09	9.41	51.91	10.75	52.71	10.81	53.35	10.87	54.80	10.98	56.25	11.07
	23	39.54	7.82	47.09	10.09	51.27	11.24	51.91	11.30	52.55	11.36	54.00	11.47	55.44	11.58
	25	39.54	8.35	47.09	10.81	50.46	11.73	51.10	11.79	51.91	11.87	53.35	11.98	54.80	12.09
	27	39.54	8.92	47.09	11.57	49.82	12.23	50.46	12.30	51.10	12.36	52.55	12.49	54.00	12.62
	29	39.54	9.52	47.09	12.36	49.02	12.72	49.66	12.79	50.46	12.87	51.91	13.00	53.35	13.13
	31	39.54	10.17	46.93	13.08	48.21	13.23	49.02	13.30	49.66	13.36	51.10	13.51	52.55	13.66
	33	39.54	10.83	46.12	13.57	47.57	13.72	48.21	13.79	49.02	13.87	50.46	14.02	51.75	14.17
35	39.54	11.55	45.32	14.06	46.77	14.23	47.57	14.30	48.21	14.38	49.66	14.55	51.10	14.70	
37	39.54	12.28	44.68	14.57	46.12	14.74	46.77	14.82	47.57	14.91	48.85	15.08	50.30	15.25	
39	39.54	13.08	43.87	14.72	45.32	15.23	46.12	15.32	46.77	15.42	48.21	15.59	49.66	15.78	
41	39.54	13.76	43.42	14.86	44.84	15.37	45.65	15.47	46.29	15.56	47.74	15.62	47.76	15.92	
43	39.54	14.11	43.10	14.94	44.61	15.42	45.41	15.54	45.81	15.58	46.87	15.65	47.19	15.96	
45	39.54	14.81	42.83	15.08	44.13	15.56	44.93	15.64	45.15	15.65	45.60	15.71	46.26	16.26	
48	39.54	15.34	44.36	15.57	48.11	15.70	49.00	15.78	49.40	15.83	49.18	15.98	50.08	16.02	
120%	-5	36.48	5.54	43.39	6.70	50.47	7.93	54.00	8.65	56.57	9.01	57.86	9.30	59.14	9.55
	-2	36.48	5.59	43.39	6.77	50.47	8.01	54.00	8.70	56.57	9.12	57.86	9.38	59.14	9.58
	0	36.48	5.64	43.39	6.82	50.47	8.10	54.00	8.72	56.57	9.20	57.86	9.43	59.14	9.60
	2	36.48	5.66	43.39	6.89	50.47	8.16	54.00	8.80	56.57	9.24	57.86	9.50	59.14	9.62
	4	36.48	5.71	43.39	6.98	50.47	8.27	54.00	8.88	56.57	9.36	57.86	9.52	59.14	9.65
	6	36.48	5.77	43.39	7.03	50.47	8.37	54.00	8.98	56.57	9.46	57.86	9.60	59.14	9.68
	8	36.48	5.83	43.39	7.10	50.47	8.48	54.00	9.09	56.57	9.56	57.86	9.63	59.14	9.72
	10	36.48	5.90	43.39	7.20	50.47	8.56	54.00	9.26	56.57	9.56	57.86	9.66	59.14	9.77
	12	36.48	6.01	43.39	7.33	50.47	8.73	54.00	9.43	55.77	9.60	57.05	9.61	58.34	9.83
	14	36.48	6.12	43.39	7.48	50.47	8.90	54.00	9.62	54.96	9.66	56.41	9.75	57.69	9.95
	16	36.48	6.24	43.39	7.63	50.47	9.07	53.68	4.10	54.32	9.80	55.61	9.92	56.89	10.10
	18	36.48	6.35	43.39	7.79	50.47	9.37	52.88	10.01	53.52	10.05	54.80	10.15	56.25	10.24
	20	36.48	6.48	43.39	8.09	50.47	10.09	52.23	10.51	52.88	10.54	54.16	10.64	55.45	10.73
	21	36.48	6.54	43.39	8.37	50.47	10.45	51.75	10.75	52.39	10.79	53.84	10.88	55.13	11.00
	23	36.48	6.99	43.39	8.97	50.47	11.19	51.11	11.22	51.75	11.28	53.03	11.39	54.32	11.49
	25	36.48	7.46	43.39	9.60	49.66	11.68	50.30	11.72	50.95	11.77	52.39	11.88	53.68	12.00
	27	36.48	7.97	43.39	10.26	49.02	12.15	49.66	12.23	50.30	12.28	51.59	12.39	52.88	12.51
	29	36.48	8.50	43.39	10.96	48.21	12.64	48.86	12.72	49.50	12.77	50.79	12.90	52.23	13.02
	31	36.48	9.07	43.39	11.70	47.41	13.15	48.21	13.21	48.86	13.28	50.14	13.41	51.43	13.55
	33	36.48	9.66	43.39	12.47	46.76	13.64	47.41	13.72	48.05	13.77	49.34	13.93	50.62	14.06
35	36.48	10.28	43.39	13.30	45.96	14.13	46.61	14.21	47.41	14.28	48.69	14.44	49.98	14.59	
37	36.48	10.94	43.39	14.17	45.32	14.64	45.96	14.72	46.61	14.79	47.89	14.95	49.18	15.12	
39	36.48	11.64	43.23	14.97	44.52	15.14	45.16	15.23	45.80	15.31	47.25	15.48	48.54	15.63	
41	36.48	11.96	42.88	15.07	44.17	15.24	44.81	15.34	45.46	15.41	46.90	15.52	47.14	15.74	
43	36.48	12.14	42.65	15.18	43.82	15.33	44.46	15.39	45.11	15.47	46.08	15.56	46.41	16.06	
45	36.48	12.28	42.42	15.32	43.40	15.48	44.00	15.54	44.71	15.59	45.15	15.61	45.94	16.41	
48	42.27	12.38	48.73	15.49	49.64	15.62	50.16	15.65	51.23	15.71	51.50	15.67	52.53	16.61	
110%	-5	33.43	4.83	39.86	6.02	46.29	7.18	49.50	7.71	52.71	8.29	56.73	8.61	58.02	8.88
	-2	33.43	4.93	39.86	6.10	46.29	7.24	49.50	7.78	52.71	8.36	56.73	8.70	58.02	8.93
	0	33.43	4.98	39.86	6.13	46.29	7.30	49.50	7.83	52.71	8.45	56.73	8.78	58.02	9.03
	2	33.43	5.08	39.86	6.19	46.29	7.41	49.50	7.92	52.71	8.54	56.73	8.91	58.02	9.15
	4	33.43	5.19	39.86	6.26	46.29	7.48	49.50	8.02	52.71	8.67	56.73	9.03	58.02	9.23

	6	33.43	5.24	39.86	6.33	46.29	7.55	49.50	8.14	52.71	8.77	56.73	9.13	58.02	9.37
	8	33.43	5.28	39.86	6.43	46.29	7.64	49.50	8.23	52.71	8.87	56.73	9.19	58.02	9.47
	10	33.43	5.35	39.86	6.52	46.29	7.75	49.50	8.37	52.71	9.01	56.73	9.26	58.02	9.55
	12	33.43	5.46	39.86	6.65	46.29	7.90	49.50	8.54	52.71	9.18	56.09	9.39	57.22	9.68
	14	33.43	5.56	39.86	6.77	46.29	8.05	49.50	8.69	52.71	9.35	55.29	9.47	56.57	9.75
	16	33.43	5.65	39.86	6.90	46.29	8.20	49.50	8.86	52.71	9.54	54.65	9.58	55.77	9.85
	18	33.43	5.76	39.86	7.03	46.29	8.37	49.50	9.11	52.71	10.00	53.84	10.07	55.13	10.17
	20	33.43	5.88	39.86	7.18	46.29	8.86	49.50	9.79	51.91	10.49	53.20	10.56	54.33	10.66
	21	33.43	5.93	39.86	7.39	46.29	9.18	49.50	10.15	51.59	10.73	52.72	10.81	54.00	10.90
	23	33.43	6.22	39.86	7.92	46.29	9.85	49.50	10.88	50.79	11.20	52.08	11.32	53.20	11.41
	25	33.43	6.63	39.86	8.46	46.29	10.52	49.50	11.66	50.14	11.70	51.27	11.81	52.55	11.90
	27	33.43	7.07	39.86	9.05	46.29	11.26	48.70	12.15	49.34	12.19	50.63	12.30	51.75	12.41
	29	33.43	7.54	39.86	9.66	46.29	12.04	48.05	12.64	48.70	12.70	49.82	12.81	51.11	12.93
	31	33.43	8.03	39.86	10.30	46.29	12.85	47.25	13.13	47.89	13.19	49.18	13.30	50.30	13.43
	33	33.43	8.54	39.86	10.98	45.97	13.55	46.61	13.62	47.25	13.68	48.38	13.81	49.66	13.95
	35	33.43	9.09	39.86	11.70	45.16	14.04	45.81	14.12	46.45	14.19	47.57	14.32	48.86	14.46
	37	33.43	9.67	39.86	12.45	44.52	14.55	45.16	14.61	45.65	14.68	46.93	14.83	48.05	14.97
	39	33.43	10.28	39.86	13.27	43.72	15.04	44.36	15.12	45.00	15.19	46.13	15.34	47.41	15.49
	41	33.43	10.38	39.86	13.37	43.37	15.15	44.01	15.22	44.66	15.30	45.54	15.45	45.98	15.60
	43	33.43	10.49	39.86	13.54	43.03	15.25	43.67	15.33	44.32	15.40	45.13	15.51	45.28	15.92
	45	33.43	10.83	39.86	13.62	42.59	15.39	43.21	15.51	43.92	15.55	44.68	15.93	44.86	16.29
	48	36.61	11.21	43.65	14.77	45.97	15.50	46.57	15.62	47.56	15.71	48.12	15.99	48.49	16.46
100%	-5	30.38	4.40	36.16	5.30	42.11	6.31	45.00	6.76	47.89	7.33	53.84	8.36	56.89	8.72
	-2	30.38	4.46	36.16	5.37	42.11	6.38	45.00	6.88	47.89	7.43	53.84	8.45	56.89	8.78
	0	30.38	4.50	36.16	5.43	42.11	6.45	45.00	6.97	47.89	7.50	53.84	8.59	56.89	8.87
	2	30.38	4.59	36.16	5.50	42.11	6.52	45.00	7.06	47.89	7.58	53.84	8.72	56.89	9.01
	4	30.38	4.62	36.16	5.55	42.11	6.62	45.00	7.16	47.89	7.68	53.84	8.80	56.89	9.11
	6	30.38	4.69	36.16	5.66	42.11	6.70	45.00	7.29	47.89	7.80	53.84	8.93	56.89	9.25
	8	30.38	4.78	36.16	5.75	42.11	6.82	45.00	7.37	47.89	7.92	53.84	9.07	56.89	9.41
	10	30.38	4.84	36.16	5.86	42.11	6.93	45.00	7.50	47.89	8.07	53.84	9.22	56.89	9.54
	12	30.38	4.91	36.16	5.97	42.11	7.07	45.00	7.63	47.89	8.22	53.84	9.39	56.09	9.62
	14	30.38	5.01	36.16	6.08	42.11	7.20	45.00	7.79	47.89	8.37	53.84	9.58	55.44	9.73
	16	30.38	5.10	36.16	6.20	42.11	7.35	45.00	7.94	47.89	8.54	53.52	9.69	54.64	9.84
	18	30.38	5.20	36.16	6.31	42.11	7.48	45.00	8.09	47.89	8.71	52.88	10.01	54.00	10.09
	20	30.38	5.29	36.16	6.44	42.11	7.71	45.00	8.50	47.89	9.33	52.07	10.49	53.19	10.58
	21	30.38	5.35	36.16	6.50	42.11	7.99	45.00	8.80	47.89	9.66	51.75	10.73	52.88	10.83
	23	30.38	5.48	36.16	6.93	42.11	8.56	45.00	9.43	47.89	10.35	51.11	11.22	52.07	11.32
	25	30.38	5.84	36.16	7.41	42.11	9.16	45.00	10.11	47.89	11.09	50.31	11.72	51.43	11.81
	27	30.38	6.23	36.16	7.90	42.11	9.79	45.00	10.81	47.89	11.87	49.50	12.21	50.63	12.32
	29	30.38	6.63	36.16	8.43	42.11	10.45	45.00	11.55	47.73	12.60	48.86	12.72	49.98	12.81
	31	30.38	7.07	36.16	8.99	42.11	11.15	45.00	12.32	47.09	13.09	48.06	13.21	49.18	13.32
	33	30.38	7.50	36.16	9.58	42.11	11.88	45.00	13.15	46.29	13.59	47.41	13.70	48.54	13.83
35	30.38	7.97	36.16	10.18	42.11	12.68	45.00	14.02	45.48	14.08	46.61	14.21	47.73	14.32	
37	30.38	8.48	36.16	10.85	42.11	13.51	44.19	14.51	44.84	14.59	45.96	14.72	46.93	14.83	
39	30.38	9.01	36.16	11.53	42.11	14.38	43.55	15.00	44.03	15.08	45.16	15.21	46.29	15.36	
41	30.38	9.43	36.16	11.95	42.11	14.90	42.88	15.11	43.70	15.31	44.38	15.57	45.61	15.68	
43	30.38	9.85	36.16	12.37	42.11	15.18	42.20	15.28	43.38	15.46	44.64	15.67	44.81	15.85	
45	30.38	10.41	36.16	12.93	42.11	15.44	41.30	15.49	43.16	15.74	44.26	15.91	43.91	16.06	
48	31.46	10.87	37.45	13.38	43.61	15.47	41.01	15.67	44.63	16.02	43.05	16.08	44.48	16.21	
90%	-5	27.32	3.89	32.63	4.67	37.93	5.51	40.50	6.01	43.07	6.40	48.37	7.35	53.68	8.42
	-2	27.32	3.93	32.63	4.72	37.93	5.58	40.50	6.10	43.07	6.47	48.37	7.43	53.68	8.50
	0	27.32	3.99	32.63	4.78	37.93	5.67	40.50	6.17	43.07	6.56	48.37	7.51	53.68	8.57
	2	27.32	4.05	32.63	4.84	37.93	5.73	40.50	6.26	43.07	6.66	48.37	7.67	53.68	8.70
	4	27.32	4.11	32.63	4.91	37.93	5.82	40.50	6.35	43.07	6.74	48.37	7.79	53.68	8.82
	6	27.32	4.17	32.63	5.01	37.93	5.93	40.50	6.47	43.07	6.86	48.37	7.91	53.68	8.97
	8	27.32	4.25	32.63	5.10	37.93	6.05	40.50	6.55	43.07	6.98	48.37	8.05	53.68	9.06
	10	27.32	4.33	32.63	5.21	37.93	6.16	40.50	6.65	43.07	7.14	48.37	8.16	53.68	9.20
	12	27.32	4.40	32.63	5.31	37.93	6.27	40.50	6.76	43.07	7.27	48.37	8.31	53.68	9.37
	14	27.32	4.48	32.63	5.40	37.93	6.39	40.50	6.90	43.07	7.41	48.37	8.46	53.68	9.54
	16	27.32	4.55	32.63	5.50	37.93	6.52	40.50	7.03	43.07	7.56	48.37	8.63	53.52	9.71
	18	27.32	4.63	32.63	5.61	37.93	6.63	40.50	7.16	43.07	7.71	48.37	8.80	52.88	10.01
	20	27.32	4.72	32.63	5.74	37.93	6.76	40.50	7.31	43.07	7.99	48.37	9.47	52.07	10.49
	21	27.32	4.76	32.63	5.78	37.93	6.88	40.50	7.56	43.07	8.28	48.37	9.81	51.75	10.73
	23	27.32	4.86	32.63	6.01	37.93	7.37	40.50	8.11	43.07	8.88	48.37	10.52	50.94	11.22
25	27.32	5.12	32.63	6.42	37.93	7.88	40.50	8.67	43.07	9.48	48.37	11.26	50.31	11.71	

	27	27.32	5.44	32.63	6.84	37.93	8.41	40.50	9.26	43.07	10.15	48.37	12.05	49.50	12.21
	29	27.32	5.80	32.63	7.29	37.93	8.97	40.50	9.88	43.07	10.85	47.89	12.60	48.86	12.70
	31	27.32	6.16	32.63	7.77	37.93	9.56	40.50	10.54	43.07	11.56	47.09	13.09	48.05	13.21
	33	27.32	6.54	32.63	8.26	37.93	10.20	40.50	11.24	43.07	12.34	46.45	13.60	47.41	13.70
	35	27.32	6.95	32.63	8.79	37.93	10.86	40.50	11.98	43.07	13.15	45.64	14.10	46.61	14.21
	37	27.32	7.37	32.63	9.33	37.93	11.56	40.50	12.75	43.07	14.02	44.84	14.59	45.96	14.70
	39	27.32	7.82	32.63	9.94	37.93	12.30	40.50	13.59	43.07	14.93	44.20	15.10	45.16	15.21
	41	27.32	8.09	32.63	10.39	37.93	12.75	40.50	13.94	43.07	15.02	43.89	15.48	44.86	15.57
	43	27.32	8.48	32.63	10.84	37.93	13.20	40.50	14.30	43.07	15.34	43.66	15.68	44.47	15.81
	45	27.32	9.02	32.63	11.38	37.93	13.74	40.50	14.78	43.07	15.76	43.42	15.85	43.79	16.02
	48	27.32	9.52	32.63	11.90	37.93	14.26	40.50	14.97	43.07	15.90	47.84	16.07	47.34	16.24
80%	-5	24.27	3.43	28.93	4.06	33.59	4.80	36.00	5.11	38.41	5.50	43.07	6.36	47.73	7.25
	-2	24.27	3.48	28.93	4.11	33.59	4.84	36.00	5.19	38.41	5.55	43.07	6.42	47.73	7.33
	0	24.27	3.54	28.93	4.16	33.59	4.90	36.00	5.25	38.41	5.65	43.07	6.51	47.73	7.43
	2	24.27	3.61	28.93	4.22	33.59	4.97	36.00	5.35	38.41	5.75	43.07	6.64	47.73	7.57
	4	24.27	3.67	28.93	4.29	33.59	5.07	36.00	5.47	38.41	5.85	43.07	6.76	47.73	7.67
	6	24.27	3.73	28.93	4.39	33.59	5.15	36.00	5.59	38.41	5.96	43.07	6.86	47.73	7.80
	8	24.27	3.80	28.93	4.49	33.59	5.27	36.00	5.68	38.41	6.09	43.07	6.96	47.73	7.95
	10	24.27	3.84	28.93	4.59	33.59	5.40	36.00	5.82	38.41	6.24	43.07	7.12	47.73	8.03
	12	24.27	3.89	28.93	4.67	33.59	5.50	36.00	5.93	38.41	6.37	43.07	7.26	47.73	8.18
	14	24.27	3.97	28.93	4.76	33.59	5.59	36.00	6.03	38.41	6.48	43.07	7.39	47.73	8.33
	16	24.27	4.02	28.93	4.84	33.59	5.71	36.00	6.14	38.41	6.59	43.07	7.54	47.73	8.48
	18	24.27	4.10	28.93	4.93	33.59	5.82	36.00	6.27	38.41	6.73	43.07	7.69	47.73	8.65
	20	24.27	4.18	28.93	5.03	33.59	5.93	36.00	6.39	38.41	6.86	43.07	7.97	47.73	9.26
	21	24.27	4.21	28.93	5.06	33.59	5.99	36.00	6.46	38.41	7.01	43.07	8.26	47.73	9.60
	23	24.27	4.29	28.93	5.18	33.59	6.27	36.00	6.88	38.41	7.50	43.07	8.84	47.73	10.30
	25	24.27	4.42	28.93	5.50	33.59	6.71	36.00	7.35	38.41	8.01	43.07	9.47	47.73	11.02
	27	24.27	4.71	28.93	5.86	33.59	7.14	36.00	7.84	38.41	8.56	43.07	10.11	47.73	11.79
	29	24.27	5.01	28.93	6.24	33.59	7.62	36.00	8.35	38.41	9.15	43.07	10.79	47.73	12.60
	31	24.27	5.31	28.93	6.63	33.59	8.11	36.00	8.90	38.41	9.75	43.07	11.53	46.93	13.10
	33	24.27	5.65	28.93	7.05	33.59	8.64	36.00	9.49	38.41	10.37	43.07	12.28	46.29	13.59
	35	24.27	5.99	28.93	7.50	33.59	9.18	36.00	10.09	38.41	11.05	43.07	13.10	45.48	14.08
	37	24.27	6.35	28.93	7.95	33.59	9.77	36.00	10.75	38.41	11.77	43.07	13.96	44.84	14.57
	39	24.27	6.73	28.93	8.48	33.59	10.39	36.00	11.43	38.41	12.53	43.07	14.87	44.04	15.08
	41	24.27	6.88	28.93	8.56	33.59	10.54	36.00	11.73	38.41	12.76	43.07	15.25	43.77	15.34
43	24.27	7.08	28.93	8.64	33.59	10.70	36.00	11.94	38.41	12.93	43.07	15.43	43.50	15.51	
45	24.27	7.28	28.93	8.74	33.59	10.90	36.00	12.19	38.41	13.16	43.07	15.60	42.96	15.76	
48	24.27	7.52	28.93	8.80	37.79	11.07	36.00	12.35	38.41	13.27	43.07	15.75	47.92	15.98	
70%	-5	21.22	3.06	25.39	3.59	29.41	4.07	31.50	4.36	33.59	4.66	37.61	5.33	41.78	6.12
	-2	21.22	3.09	25.39	3.61	29.41	4.09	31.50	4.45	33.59	4.74	37.61	5.41	41.78	6.21
	0	21.22	3.10	25.39	3.66	29.41	4.18	31.50	4.53	33.59	4.82	37.61	5.52	41.78	6.29
	2	21.22	3.12	25.39	3.67	29.41	4.25	31.50	4.61	33.59	4.91	37.61	5.64	41.78	6.39
	4	21.22	3.16	25.39	3.77	29.41	4.34	31.50	4.70	33.59	5.02	37.61	5.73	41.78	6.54
	6	21.22	3.21	25.39	3.83	29.41	4.45	31.50	4.85	33.59	5.13	37.61	5.83	41.78	6.67
	8	21.22	3.27	25.39	3.94	29.41	4.55	31.50	4.92	33.59	5.24	37.61	6.00	41.78	6.80
	10	21.22	3.34	25.39	4.01	29.41	4.67	31.50	5.03	33.59	5.39	37.61	6.12	41.78	6.88
	12	21.22	3.42	25.39	4.06	29.41	4.76	31.50	5.12	33.59	5.48	37.61	6.24	41.78	7.01
	14	21.22	3.48	25.39	4.14	29.41	4.84	31.50	5.20	33.59	5.57	37.61	6.35	41.78	7.14
	16	21.22	3.53	25.39	4.21	29.41	4.93	31.50	5.31	33.59	5.69	37.61	6.46	41.78	7.27
	18	21.22	3.59	25.39	4.29	29.41	5.03	31.50	5.40	33.59	5.78	37.61	6.59	41.78	7.43
	20	21.22	3.65	25.39	4.37	29.41	5.12	31.50	5.50	33.59	5.90	37.61	6.73	41.78	7.63
	21	21.22	3.68	25.39	4.40	29.41	5.16	31.50	5.56	33.59	5.95	37.61	6.82	41.78	7.90
	23	21.22	3.74	25.39	4.48	29.41	5.27	31.50	5.74	33.59	6.25	37.61	7.31	41.78	8.47
	25	21.22	3.82	25.39	4.67	29.41	5.61	31.50	6.14	33.59	6.67	37.61	7.82	41.78	9.05
	27	21.22	4.04	25.39	4.97	29.41	5.99	31.50	6.54	33.59	7.12	37.61	8.35	41.78	9.67
	29	21.22	4.29	25.39	5.27	29.41	6.37	31.50	6.97	33.59	7.58	37.61	8.90	41.78	10.34
	31	21.22	4.53	25.39	5.59	29.41	6.78	31.50	7.41	33.59	8.07	37.61	9.49	41.78	11.02
	33	21.22	4.82	25.39	5.95	29.41	7.22	31.50	7.88	33.59	8.60	37.61	10.11	41.78	11.75
	35	21.22	5.10	25.39	6.31	29.41	7.65	31.50	8.39	33.59	9.15	37.61	10.77	41.78	12.53
	37	21.22	5.39	25.39	6.69	29.41	8.14	31.50	8.90	33.59	9.73	37.61	11.47	41.78	13.34
	39	21.22	5.71	25.39	7.09	29.41	8.64	31.50	9.47	33.59	10.34	37.61	12.19	41.78	14.21
	41	21.22	5.96	25.39	7.34	29.41	8.89	31.50	9.78	33.59	10.65	37.61	12.69	41.78	14.84
43	21.22	6.44	25.39	7.84	29.41	9.25	31.50	10.31	33.59	10.97	37.61	13.15	41.78	15.30	
45	21.22	6.59	25.39	8.01	29.41	9.45	31.50	10.47	33.59	11.51	37.61	13.87	41.78	15.89	
48	21.22	6.76	25.39	8.08	29.41	9.55	31.50	10.64	33.59	11.83	37.61	14.49	41.78	16.26	

60%	-5	18.16	2.61	21.70	3.03	25.23	3.53	27.00	3.76	28.77	4.06	32.30	4.56	35.84	5.23
	-2	18.16	2.63	21.70	3.08	25.23	3.60	27.00	3.82	28.77	4.10	32.30	4.63	35.84	5.27
	0	18.16	2.67	21.70	3.12	25.23	3.64	27.00	3.86	28.77	4.17	32.30	4.70	35.84	5.33
	2	18.16	2.72	21.70	3.19	25.23	3.71	27.00	3.94	28.77	4.23	32.30	4.79	35.84	5.40
	4	18.16	2.79	21.70	3.25	25.23	3.78	27.00	3.99	28.77	4.29	32.30	4.87	35.84	5.48
	6	18.16	2.82	21.70	3.31	25.23	3.85	27.00	4.08	28.77	4.38	32.30	4.97	35.84	5.61
	8	18.16	2.87	21.70	3.36	25.23	3.93	27.00	4.15	28.77	4.47	32.30	5.06	35.84	5.70
	10	18.16	2.93	21.70	3.44	25.23	3.99	27.00	4.27	28.77	4.55	32.30	5.16	35.84	5.78
	12	18.16	2.99	21.70	3.49	25.23	4.06	27.00	4.35	28.77	4.63	32.30	5.25	35.84	5.88
	14	18.16	3.02	21.70	3.55	25.23	4.12	27.00	4.42	28.77	4.72	32.30	5.35	35.84	5.99
	16	18.16	3.06	21.70	3.61	25.23	4.19	27.00	4.50	28.77	4.80	32.30	5.44	35.84	6.10
	18	18.16	3.12	21.70	3.66	25.23	4.27	27.00	4.57	28.77	4.89	32.30	5.54	35.84	6.22
	20	18.16	3.15	21.70	3.74	25.23	4.35	27.00	4.67	28.77	4.99	32.30	5.65	35.84	6.35
	21	18.16	3.19	21.70	3.76	25.23	4.38	27.00	4.70	28.77	5.03	32.30	5.71	35.84	6.40
	23	18.16	3.23	21.70	3.84	25.23	4.46	27.00	4.80	28.77	5.12	32.30	5.93	35.84	6.82
	25	18.16	3.29	21.70	3.89	25.23	4.63	27.00	5.03	28.77	5.44	32.30	6.33	35.84	7.27
	27	18.16	3.42	21.70	4.14	25.23	4.93	27.00	5.37	28.77	5.80	32.30	6.74	35.84	7.76
	29	18.16	3.61	21.70	4.38	25.23	5.25	27.00	5.71	28.77	6.18	32.30	7.20	35.84	8.29
	31	18.16	3.84	21.70	4.65	25.23	5.57	27.00	6.06	28.77	6.57	32.30	7.65	35.84	8.82
	33	18.16	4.04	21.70	4.93	25.23	5.91	27.00	6.44	28.77	6.99	32.30	8.14	35.84	9.41
35	18.16	4.29	21.70	5.23	25.23	6.27	27.00	6.84	28.77	7.42	32.30	8.67	35.84	10.01	
37	18.16	4.53	21.70	5.54	25.23	6.65	27.00	7.25	28.77	7.88	32.30	9.22	35.84	10.66	
39	18.16	4.78	21.70	5.86	25.23	7.05	27.00	7.69	28.77	8.37	32.30	9.79	35.84	11.34	
41	18.16	4.93	21.70	6.11	25.23	7.30	27.00	8.00	28.77	8.68	32.30	10.25	35.84	11.85	
43	18.16	5.09	21.70	6.37	25.23	7.56	27.00	8.24	28.77	8.98	32.30	10.68	35.84	12.36	
45	18.16	5.33	21.70	6.69	25.23	7.87	27.00	8.54	28.77	9.42	32.30	11.16	35.84	13.05	
48	18.16	5.53	21.70	6.99	25.23	8.13	27.00	8.77	28.77	9.79	32.30	11.57	35.84	13.66	
50%	-5	15.19	2.27	18.16	2.62	21.05	3.01	22.50	3.16	23.95	3.33	26.84	3.79	29.89	4.08
	-2	15.19	2.29	18.16	2.68	21.05	3.05	22.50	3.20	23.95	3.39	26.84	3.84	29.89	4.14
	0	15.19	2.32	18.16	2.72	21.05	3.10	22.50	3.24	23.95	3.43	26.84	3.90	29.89	4.21
	2	15.19	2.36	18.16	2.75	21.05	3.16	22.50	3.29	23.95	3.49	26.84	3.92	29.89	4.29
	4	15.19	2.38	18.16	2.80	21.05	3.19	22.50	3.33	23.95	3.56	26.84	4.02	29.89	4.40
	6	15.19	2.42	18.16	2.85	21.05	3.24	22.50	3.41	23.95	3.62	26.84	4.08	29.89	4.53
	8	15.19	2.48	18.16	2.90	21.05	3.29	22.50	3.48	23.95	3.67	26.84	4.14	29.89	4.67
	10	15.19	2.53	18.16	2.93	21.05	3.34	22.50	3.54	23.95	3.78	26.84	4.25	29.89	4.74
	12	15.19	2.55	18.16	2.97	21.05	3.40	22.50	3.61	23.95	3.85	26.84	4.33	29.89	4.82
	14	15.19	2.59	18.16	3.00	21.05	3.44	22.50	3.68	23.95	3.91	26.84	4.40	29.89	4.91
	16	15.19	2.63	18.16	3.04	21.05	3.50	22.50	3.74	23.95	3.97	26.84	4.48	29.89	4.99
	18	15.19	2.66	18.16	3.10	21.05	3.55	22.50	3.80	23.95	4.04	26.84	4.55	29.89	5.08
	20	15.19	2.70	18.16	3.14	21.05	3.61	22.50	3.85	23.95	4.12	26.84	4.63	29.89	5.18
	21	15.19	2.72	18.16	3.17	21.05	3.65	22.50	3.89	23.95	4.16	26.84	4.69	29.89	5.23
	23	15.19	2.76	18.16	3.21	21.05	3.70	22.50	3.97	23.95	4.23	26.84	4.76	29.89	5.35
	25	15.19	2.80	18.16	3.27	21.05	3.78	22.50	4.04	23.95	4.36	26.84	5.01	29.89	5.71
	27	15.19	2.85	18.16	3.40	21.05	3.99	22.50	4.31	23.95	4.63	26.84	5.33	29.89	6.08
	29	15.19	3.00	18.16	3.59	21.05	4.23	22.50	4.57	23.95	4.93	26.84	5.67	29.89	6.48
	31	15.19	3.17	18.16	3.80	21.05	4.48	22.50	4.86	23.95	5.23	26.84	6.03	29.89	6.90
	33	15.19	3.36	18.16	4.02	21.05	4.76	22.50	5.14	23.95	5.55	26.84	6.40	29.89	7.33
35	15.19	3.55	18.16	4.25	21.05	5.03	22.50	5.44	23.95	5.88	26.84	6.80	29.89	7.78	
37	15.19	3.74	18.16	4.50	21.05	5.33	22.50	5.76	23.95	6.23	26.84	7.22	29.89	8.27	
39	15.19	3.95	18.16	4.74	21.05	5.63	22.50	6.10	23.95	6.61	26.84	7.65	29.89	8.79	
41	15.19	4.11	18.16	4.95	21.05	5.83	22.50	6.39	23.95	6.90	26.84	8.06	29.89	9.19	
43	15.19	4.38	18.16	5.29	21.05	6.04	22.50	6.67	23.95	7.08	26.84	8.47	29.89	9.60	
45	15.19	4.48	18.16	5.42	21.05	6.45	22.50	7.19	23.95	7.37	26.84	9.28	29.89	10.42	
48	15.19	4.59	18.16	5.57	21.05	6.82	22.50	7.65	23.95	7.70	26.84	10.03	29.89	11.21	

	-13.7	-15	35.08	12.46	34.92	12.91	34.76	13.36	34.76	13.59	34.76	13.80	34.61	14.25
	-11.8	-13	36.51	12.82	36.51	13.24	36.35	13.67	36.35	13.89	36.35	14.10	36.19	14.53
	-9.8	-11	38.26	13.17	38.10	13.59	38.10	13.99	38.10	14.20	37.94	14.40	37.94	14.80
	-9.5	-10	39.21	13.36	39.05	13.75	39.05	14.15	38.89	14.35	38.89	14.55	38.73	14.95
	-8.5	-9.1	40.00	13.50	39.84	13.90	39.84	14.29	39.84	14.48	39.69	14.68	39.69	15.07
	-7	-7.6	41.43	13.77	41.43	14.15	41.27	14.52	41.27	14.72	41.27	14.90	41.11	15.28
	-5	-5.6	43.65	14.12	43.49	14.47	43.49	14.83	43.34	15.00	43.34	15.18	43.18	15.55
	-3	-3.7	45.72	14.43	45.72	13.11	45.56	15.12	45.56	15.28	45.56	15.45	43.65	14.80
	0	-0.7	49.37	14.90	49.37	15.21	49.21	15.53	48.42	15.28	46.83	14.65	43.65	13.44
	3	2.2	53.34	15.33	53.18	15.61	50.00	14.45	48.42	13.89	46.83	13.34	43.65	12.24
	5	4.1	56.03	15.61	53.18	14.67	50.00	13.59	48.42	13.07	46.83	12.56	43.65	11.54
	7	6	56.35	14.82	53.18	13.79	50.00	12.79	48.42	12.31	46.83	11.83	43.65	10.88
	9	7.9	56.35	13.92	53.18	12.97	50.00	12.04	48.42	11.44	46.83	11.15	43.65	10.27
	11	9.8	56.35	13.11	53.18	12.22	50.00	11.36	48.42	10.93	46.83	10.51	43.65	9.70
	13	11.8	56.35	12.31	53.18	11.49	50.00	10.70	48.42	10.30	46.83	9.92	43.65	9.15
	15	13.7	56.35	11.61	53.18	10.85	50.00	10.10	48.42	9.73	46.83	9.37	43.65	8.67
90%	-19.8	-20	31.69	12.49	31.53	12.92	31.53	13.37	31.37	13.59	31.37	13.82	31.37	14.25
	-18.8	-19	32.17	12.62	32.17	13.07	32.01	13.50	32.01	13.72	32.01	13.94	31.85	14.37
	-16.7	-17	33.44	12.94	33.27	13.36	33.27	13.77	33.27	13.99	33.12	14.19	33.12	14.60
	-13.7	-15	34.86	13.25	34.70	13.65	34.70	14.05	34.54	14.25	34.54	14.45	34.54	14.85
	-11.8	-13	36.28	13.57	36.28	13.95	36.13	14.33	36.13	14.53	36.13	14.72	35.97	15.10
	-9.8	-11	38.03	13.89	38.03	14.25	37.87	14.62	37.87	14.80	37.87	15.00	37.71	15.36
	-9.5	-10	38.98	14.05	38.82	14.42	38.82	14.77	38.66	14.95	38.66	15.13	38.66	15.48
	-8.5	-9.1	39.77	14.20	39.77	14.55	39.61	14.90	39.61	15.07	39.61	15.25	39.14	15.40
	-7	-7.6	41.20	14.43	41.20	14.77	41.04	15.11	41.04	15.28	41.04	15.45	39.14	14.70
	-5	-5.6	43.42	14.75	43.26	15.07	43.26	15.38	43.10	15.55	41.99	15.07	39.14	13.82
	-3	-3.7	45.48	15.03	45.48	15.33	45.00	15.40	43.42	14.78	41.99	14.19	39.14	13.02
	0	-0.7	49.28	15.46	47.85	15.08	45.00	13.97	43.42	13.42	41.99	12.89	39.14	11.84
	3	2.2	50.71	14.73	47.85	13.72	45.00	12.72	43.42	12.24	41.99	11.76	39.14	10.83
	5	4.1	50.71	13.85	47.85	12.91	45.00	11.99	43.42	11.53	41.99	11.10	39.14	10.22
	7	6	50.71	13.02	47.85	12.16	45.00	11.29	43.42	10.88	41.99	10.46	39.14	9.65
9	7.9	50.71	12.28	47.85	11.44	45.00	10.65	43.42	10.26	41.99	9.88	39.14	9.12	
11	9.8	50.71	11.56	47.85	10.80	45.00	10.07	43.42	9.70	41.99	9.34	39.14	8.64	
13	11.8	50.71	10.88	47.85	10.18	45.00	9.48	43.42	9.15	41.99	8.82	39.14	8.16	
15	13.7	50.71	10.28	47.85	9.62	45.00	8.99	43.42	8.67	41.99	8.35	39.14	7.74	
80%	-19.8	-20	31.59	13.35	31.43	13.74	31.43	14.14	31.43	14.33	31.27	14.53	31.27	14.92
	-18.8	-19	32.06	13.47	32.06	13.87	31.90	14.25	31.90	14.45	31.90	14.63	31.75	15.03
	-16.7	-17	33.33	13.75	33.18	14.12	33.18	14.50	33.18	14.68	33.18	14.87	33.02	15.23
	-13.7	-15	34.76	14.04	34.60	14.38	34.60	14.75	34.60	14.92	34.44	15.10	34.44	15.46
	-11.8	-13	36.19	14.32	36.19	14.67	36.03	15.00	36.03	15.16	36.03	15.35	34.92	14.93
	-9.8	-11	37.94	14.60	37.94	14.93	37.78	15.26	37.78	15.41	37.46	15.38	34.92	14.10
	-9.5	-10	38.89	14.75	38.72	15.06	38.73	15.38	38.73	15.55	37.46	14.93	34.92	13.69
	-8.5	-9.1	39.68	14.88	36.88	15.20	39.52	15.50	38.73	15.15	37.46	14.53	34.92	13.32
	-7	-7.6	41.11	15.10	41.11	15.40	40.00	15.06	38.73	14.47	37.46	13.89	34.92	12.74
	-5	-5.6	43.33	15.36	42.54	15.28	40.00	14.15	38.73	13.60	37.46	13.05	34.92	11.99
	-3	-3.7	45.08	15.45	42.54	14.38	40.00	13.32	38.73	12.82	37.46	12.31	34.92	11.33
	0	-0.7	45.08	14.02	42.54	13.05	40.00	12.13	38.73	11.68	37.46	11.21	34.92	10.33
	3	2.2	45.08	12.77	42.54	11.91	40.00	11.08	38.73	10.66	37.46	10.26	34.92	9.47
	5	4.1	45.08	12.03	42.54	11.23	40.00	10.45	38.73	10.07	37.46	9.70	34.92	8.95
	7	6	45.08	11.33	42.54	10.60	40.00	9.87	38.73	9.52	37.46	9.17	34.92	8.47
9	7.9	45.08	10.70	42.54	10.00	40.00	9.32	38.73	8.99	37.46	8.67	34.92	8.02	
11	9.8	45.08	10.10	42.54	9.45	40.00	8.82	38.73	8.50	37.46	8.20	34.92	7.61	
13	11.8	45.08	9.52	42.54	8.92	40.00	8.34	38.73	8.04	37.46	7.76	34.92	7.19	
15	13.7	45.08	9.00	42.54	8.45	40.00	7.91	38.73	7.62	37.46	7.36	34.92	6.84	
70%	-19.8	-20	31.36	14.22	31.20	14.55	31.20	14.90	31.20	15.06	31.20	15.25	30.41	15.08
	-18.8	-19	31.83	14.33	31.83	14.67	31.68	15.00	31.68	15.16	31.68	15.35	30.41	14.77
	-16.7	-17	33.10	14.57	33.10	14.90	32.94	15.21	32.94	15.38	32.62	13.70	30.41	14.09
	-13.7	-15	34.52	14.82	34.37	15.13	34.37	15.45	33.73	15.21	32.62	14.60	30.41	13.39
	-11.8	-13	35.95	15.06	35.95	15.36	35.00	15.00	33.73	14.42	32.62	13.84	30.41	12.69
	-9.8	-11	37.69	15.31	37.22	15.30	35.00	14.17	33.73	13.62	32.62	13.07	30.41	12.01
	-9.5	-10	38.64	15.45	37.22	14.85	35.00	13.75	33.73	13.22	32.62	12.71	30.41	11.68
	-8.5	-9.1	39.43	15.53	37.22	14.45	35.00	13.39	33.73	12.87	32.62	12.37	30.41	11.38
	-7	-7.6	39.43	14.83	37.22	13.80	35.00	12.81	33.73	12.32	32.62	11.84	30.41	10.90
	-5	-5.6	39.43	13.94	37.22	12.99	35.00	12.06	33.73	11.59	32.62	13.70	30.41	10.28
-3	-3.7	39.43	13.12	37.22	12.24	35.00	11.38	33.73	10.95	32.62	10.53	30.41	9.72	

	0	-0.7	39.43	11.94	37.22	11.16	35.00	10.38	33.73	10.00	32.62	9.63	30.41	8.90
	3	2.2	39.43	10.91	37.22	10.22	35.00	9.52	33.73	9.17	32.62	8.84	30.41	8.17
	5	4.1	39.43	10.30	37.22	9.63	35.00	9.00	33.73	8.67	32.62	8.35	30.41	7.74
	7	6	39.43	9.73	37.22	9.12	35.00	8.50	33.73	8.20	32.62	7.92	30.41	7.34
	9	7.9	39.43	9.20	37.22	8.62	35.00	8.06	33.73	7.77	32.62	7.51	30.41	6.96
	11	9.8	39.43	8.70	37.22	8.16	35.00	7.64	33.73	7.37	32.62	7.13	30.41	6.61
	13	11.8	39.43	8.22	37.22	7.72	35.00	7.23	33.73	6.99	32.62	6.74	30.41	6.28
	15	13.7	39.43	7.79	37.22	7.32	35.00	6.86	33.73	6.64	32.62	6.41	30.41	5.98
60%	-19.8	-20	31.27	15.08	31.11	15.36	30.00	14.78	29.05	14.20	28.10	13.64	26.19	12.51
	-18.8	-19	31.75	15.18	31.75	15.46	30.00	14.47	29.05	13.90	28.10	13.34	26.19	12.24
	-16.7	-17	33.02	15.38	31.91	14.90	30.00	13.80	29.05	13.27	28.10	12.74	26.19	11.71
	-13.7	-15	33.81	15.21	31.91	14.15	30.00	13.12	29.05	12.62	28.10	12.12	26.19	11.14
	-11.8	-13	33.81	14.40	31.91	13.40	30.00	12.44	29.05	11.98	28.10	11.51	26.19	10.65
	-9.8	-11	33.81	13.60	31.91	12.67	30.00	11.78	29.05	11.33	28.10	10.90	26.19	10.05
	-9.5	-10	33.81	13.22	31.91	12.32	30.00	11.44	29.05	11.03	28.10	10.60	26.19	9.77
	-8.5	-9.1	33.81	12.87	31.91	12.01	30.00	11.16	29.05	10.75	28.10	10.33	26.19	9.53
	-7	-7.6	33.81	12.31	31.91	11.49	30.00	10.68	29.05	10.30	28.10	9.90	26.19	9.15
	-5	-5.6	33.81	11.59	31.91	10.83	30.00	10.08	29.05	9.72	28.10	9.35	26.19	8.65
	-3	-3.7	33.81	10.95	31.91	10.23	30.00	9.53	29.05	9.20	28.10	8.85	26.19	8.19
	0	-0.7	33.81	10.00	31.91	9.37	30.00	8.74	29.05	8.44	28.10	8.12	26.19	7.52
	3	2.2	33.81	9.17	31.91	8.60	30.00	8.04	29.05	7.76	28.10	7.49	26.19	6.94
	5	4.1	33.81	8.67	31.91	8.14	30.00	7.61	29.05	7.36	28.10	7.09	26.19	6.59
	7	6	33.81	8.20	31.91	7.71	30.00	7.21	29.05	6.98	28.10	6.74	26.19	6.26
9	7.9	33.81	7.77	31.91	7.31	30.00	6.84	29.05	6.63	28.10	6.39	26.19	5.96	
11	9.8	33.81	7.37	31.91	6.94	30.00	6.51	29.05	6.30	28.10	6.08	26.19	5.68	
13	11.8	33.81	6.98	31.91	6.58	30.00	6.18	29.05	5.98	28.10	5.78	26.19	5.40	
15	13.7	33.81	6.64	31.91	6.25	30.00	5.88	29.05	5.70	28.10	5.51	26.19	5.15	
50%	-19.8	-20	28.17	13.72	26.58	12.77	25.00	11.86	24.05	11.43	23.26	10.98	21.68	10.12
	-18.8	-19	28.17	13.42	26.58	12.51	25.00	11.63	24.05	11.18	23.26	10.75	21.68	9.92
	-16.7	-17	28.17	12.81	26.58	11.94	25.00	11.11	24.05	10.70	23.26	10.30	21.68	9.50
	-13.7	-15	28.17	12.19	26.58	11.38	25.00	10.58	24.05	10.20	23.26	9.82	21.68	9.07
	-11.8	-13	28.17	11.58	26.58	10.81	25.00	10.07	24.05	9.70	23.26	9.33	21.68	8.64
	-9.8	-11	28.17	10.96	26.58	10.25	25.00	9.55	24.05	9.20	23.26	8.87	21.68	8.20
	-9.5	-10	28.17	10.66	26.58	9.97	25.00	9.30	24.05	8.97	23.26	8.64	21.68	7.99
	-8.5	-9.1	28.17	10.40	26.58	9.73	25.00	9.07	24.05	8.75	23.26	8.44	21.68	7.81
	-7	-7.6	28.17	9.97	26.58	9.33	25.00	8.70	24.05	8.40	23.26	8.11	21.68	7.51
	-5	-5.6	28.17	9.40	26.58	8.82	25.00	8.24	24.05	7.96	23.26	7.67	21.68	7.11
	-3	-3.7	28.17	8.90	26.58	8.35	25.00	7.81	24.05	7.54	23.26	7.27	21.68	6.76
	0	-0.7	28.17	8.17	26.58	7.67	25.00	7.19	24.05	6.94	23.26	6.71	21.68	6.25
	3	2.2	28.17	7.52	26.58	7.08	25.00	6.63	24.05	6.41	23.26	6.20	21.68	5.78
	5	4.1	28.17	7.14	26.58	6.71	25.00	6.30	24.05	6.10	23.26	5.90	21.68	5.50
	7	6	28.17	6.78	26.58	6.38	25.00	6.00	24.05	5.80	23.26	5.61	21.68	5.25
9	7.9	28.17	6.43	26.58	6.06	25.00	5.70	24.05	5.53	23.26	5.35	21.68	5.00	
11	9.8	28.17	6.11	26.58	5.76	25.00	5.43	24.05	5.27	23.26	5.10	21.68	4.77	
13	11.8	28.17	5.81	26.58	5.48	25.00	5.17	24.05	5.02	23.26	4.85	21.68	4.55	
15	13.7	28.17	5.53	26.58	5.23	25.00	4.93	24.05	4.78	23.26	4.63	21.68	4.35	

Note:

1. [] is shown as reference.
2. The above table shows the average value of conditions may operate.
3. It is recommended to connect less than 130%.

18HP cooling mode

Combination (%) (Capacity index)	Outdoor temperature (°C DB)	Indoor temperature(°C DB/WD)													
		DB:20.8,WB:14		DB:23.3,WB:16		DB:25.8,WB:18		DB:27,WB:19		DB:28.2,WB:20		DB:30.7,WB:22		DB:32,WB:24	
		TC	PI	TC	PI	TC	PI	TC	PI	TC	PI	TC	PI	TC	PI
130%	-5	43.93	6.21	52.32	7.58	60.71	8.13	63.03	8.46	66.06	8.70	67.68	9.46	69.38	9.52
	-2	43.93	6.21	52.32	7.73	60.71	8.13	63.03	8.51	66.06	8.70	67.68	9.58	69.38	9.62
	0	43.93	6.32	52.32	7.86	60.71	8.43	63.03	8.98	66.06	9.21	67.68	9.70	69.38	9.74
	2	43.93	6.43	52.32	7.88	60.71	8.72	63.03	9.48	66.06	9.31	67.68	9.77	69.38	9.89
	4	43.93	6.58	52.32	8.03	60.71	9.02	63.03	9.52	66.06	9.43	67.68	9.76	69.38	10.08
	6	43.93	6.70	52.32	8.19	60.71	9.35	63.03	9.60	65.33	9.73	66.85	9.76	68.62	10.15
	8	43.93	6.86	52.32	8.38	60.71	9.82	63.03	10.07	64.52	10.04	66.12	3.90	67.74	10.25
	10	43.93	7.01	52.32	8.56	60.71	10.18	63.03	10.41	63.75	4.04	65.36	4.06	66.96	10.55
	12	43.93	7.13	52.32	8.73	60.71	10.39	62.14	4.03	63.03	4.06	64.46	4.07	66.07	10.61
	14	43.93	7.27	52.32	8.89	60.53	4.05	61.43	4.06	62.14	4.08	63.75	4.09	65.36	10.85
	16	43.93	7.40	52.32	9.08	59.82	4.06	60.53	4.08	61.25	4.10	62.86	4.12	64.46	11.02
	18	43.93	7.54	52.32	9.26	58.93	10.86	59.64	10.92	60.53	10.98	62.14	11.08	63.75	11.19
	20	43.93	7.70	52.32	9.85	58.03	11.39	58.93	11.45	59.64	11.51	61.25	11.62	62.86	11.74
	21	43.93	7.91	52.32	10.20	57.68	11.66	58.57	11.72	59.28	11.78	60.89	11.90	62.50	12.01
	23	43.93	8.48	52.32	10.94	56.96	12.19	57.68	12.25	58.39	12.31	60.00	12.43	61.60	12.56
	25	43.93	9.06	52.32	11.72	56.07	12.72	56.78	12.78	57.68	12.87	59.28	12.99	60.89	13.11
	27	43.93	9.67	52.32	12.54	55.36	13.26	56.07	13.34	56.78	13.40	58.39	13.54	60.00	13.68
	29	43.93	10.33	52.32	13.40	54.46	13.79	55.18	13.87	56.07	13.95	57.68	14.10	59.28	14.24
	31	43.93	11.02	52.14	14.18	53.57	14.34	54.46	14.42	55.18	14.48	56.78	14.65	58.39	14.81
	33	43.93	11.74	51.25	14.71	52.86	14.87	53.57	14.95	54.46	15.04	56.07	15.20	57.50	15.37
	35	43.93	12.52	50.35	15.24	51.96	15.43	52.86	15.51	53.57	15.59	55.18	15.78	56.78	15.94
37	43.93	13.32	49.64	15.80	51.25	15.98	51.96	16.06	52.86	16.16	54.28	16.35	55.89	16.53	
39	43.93	14.18	48.75	15.96	50.35	16.51	51.25	16.61	51.96	16.72	53.57	16.90	55.18	17.11	
41	43.93	14.92	48.25	16.11	49.83	16.67	50.72	16.77	51.43	16.87	53.04	16.94	53.06	17.26	
43	43.93	15.30	47.89	16.19	49.56	16.71	50.46	16.85	50.90	16.90	52.08	16.97	52.43	17.30	
45	43.93	16.06	47.59	16.35	49.03	16.87	49.93	16.96	50.16	16.97	50.66	17.03	51.40	17.63	
48	43.93	16.63	49.29	16.88	53.46	17.03	54.45	17.11	54.88	17.17	54.64	17.32	55.64	17.37	
120%	-5	40.54	6.00	48.21	7.27	56.07	8.60	60.00	9.37	62.86	9.77	64.29	10.08	65.72	10.35
	-2	40.54	6.06	48.21	7.35	56.07	8.68	60.00	9.43	62.86	9.89	64.29	10.17	65.72	10.39
	0	40.54	6.12	48.21	7.39	56.07	8.78	60.00	9.45	62.86	9.97	64.29	10.23	65.72	10.41
	2	40.54	6.13	48.21	7.47	56.07	8.84	60.00	9.54	62.86	10.01	64.29	10.30	65.72	10.43
	4	40.54	6.19	48.21	7.57	56.07	8.97	60.00	9.63	62.86	10.15	64.29	10.33	65.72	10.46
	6	40.54	6.26	48.21	7.63	56.07	9.07	60.00	9.74	62.86	10.26	64.29	10.41	65.72	10.49
	8	40.54	6.32	48.21	7.70	56.07	9.20	60.00	9.86	62.86	10.36	64.29	10.44	65.72	10.54
	10	40.54	6.39	48.21	7.80	56.07	9.28	60.00	10.04	62.86	10.37	64.29	10.48	65.72	10.59
	12	40.54	6.51	48.21	7.95	56.07	9.46	60.00	10.22	61.97	10.41	63.39	10.42	64.82	10.66
	14	40.54	6.64	48.21	8.11	56.07	9.65	60.00	10.43	61.07	10.48	62.68	10.58	64.10	10.78
	16	40.54	6.76	48.21	8.28	56.07	9.83	59.64	4.10	60.36	10.63	61.78	10.75	63.21	10.95
	18	40.54	6.88	48.21	8.44	56.07	10.16	58.75	10.86	59.46	10.90	60.89	11.00	62.50	11.10
	20	40.54	7.03	48.21	8.77	56.07	10.94	58.04	11.39	58.75	11.43	60.18	11.53	61.61	11.64
	21	40.54	7.09	48.21	9.08	56.07	11.33	57.50	11.66	58.21	11.70	59.82	11.80	61.25	11.92
	23	40.54	7.58	48.21	9.73	56.07	12.13	56.79	12.17	57.50	12.23	58.93	12.35	60.36	12.46
	25	40.54	8.09	48.21	10.41	55.18	12.66	55.89	12.70	56.61	12.76	58.21	12.88	59.64	13.01
	27	40.54	8.65	48.21	11.12	54.46	13.17	55.18	13.25	55.89	13.32	57.32	13.44	58.75	13.56
	29	40.54	9.22	48.21	11.88	53.57	13.70	54.29	13.79	55.00	13.85	56.43	13.99	58.04	14.11
	31	40.54	9.83	48.21	12.68	52.68	14.26	53.57	14.32	54.29	14.40	55.72	14.54	57.14	14.69
	33	40.54	10.47	48.21	13.52	51.96	14.79	52.68	14.87	53.39	14.93	54.82	15.10	56.25	15.24
	35	40.54	11.14	48.21	14.42	51.07	15.32	51.79	15.41	52.68	15.49	54.10	15.65	55.53	15.81
37	40.54	11.86	48.21	15.36	50.36	15.88	51.07	15.96	51.79	16.04	53.21	16.20	54.64	16.39	
39	40.54	12.62	48.04	16.22	49.47	16.41	50.18	16.51	50.89	16.59	52.50	16.78	53.93	16.94	
41	40.54	12.97	47.65	16.34	49.08	16.53	49.79	16.63	50.51	16.71	52.11	16.82	52.38	17.07	
43	40.54	13.16	47.39	16.46	48.69	16.63	49.40	16.69	50.12	16.77	51.21	16.87	51.56	17.41	
45	40.54	13.31	47.13	16.61	48.22	16.78	48.89	16.85	49.68	16.90	50.17	16.92	51.05	17.79	
48	46.97	13.42	54.14	16.79	55.15	16.93	55.74	16.97	56.93	17.03	57.23	16.98	58.36	18.01	
110%	-5	37.14	5.24	44.29	6.52	51.43	7.78	55.00	8.36	58.57	8.99	63.04	9.34	64.47	9.63
	-2	37.14	5.34	44.29	6.61	51.43	7.85	55.00	8.44	58.57	9.06	63.04	9.43	64.47	9.68
	0	37.14	5.39	44.29	6.65	51.43	7.91	55.00	8.49	58.57	9.16	63.04	9.52	64.47	9.79
	2	37.14	5.51	44.29	6.71	51.43	8.03	55.00	8.59	58.57	9.26	63.04	9.66	64.47	9.92
	4	37.14	5.62	44.29	6.79	51.43	8.11	55.00	8.69	58.57	9.40	63.04	9.79	64.47	10.01

	6	37.14	5.68	44.29	6.86	51.43	8.19	55.00	8.83	58.57	9.51	63.04	9.90	64.47	10.16
	8	37.14	5.73	44.29	6.97	51.43	8.28	55.00	8.92	58.57	9.62	63.04	9.96	64.47	10.27
	10	37.14	5.80	44.29	7.07	51.43	8.40	55.00	9.07	58.57	9.77	63.04	10.03	64.47	10.36
	12	37.14	5.92	44.29	7.21	51.43	8.56	55.00	9.26	58.57	9.96	62.33	10.18	63.57	10.49
	14	37.14	6.02	44.29	7.33	51.43	8.73	55.00	9.42	58.57	10.14	61.43	10.26	62.86	10.57
	16	37.14	6.13	44.29	7.48	51.43	8.89	55.00	9.61	58.57	10.35	60.72	10.39	61.96	10.68
	18	37.14	6.25	44.29	7.62	51.43	9.07	55.00	9.87	58.57	10.84	59.82	10.92	61.25	11.02
	20	37.14	6.37	44.29	7.78	51.43	9.61	55.00	10.61	57.68	11.37	59.11	11.45	60.36	11.55
	21	37.14	6.43	44.29	8.01	51.43	9.96	55.00	11.00	57.32	11.64	58.58	11.72	60.00	11.82
	23	37.14	6.74	44.29	8.58	51.43	10.67	55.00	11.80	56.43	12.15	57.86	12.27	59.11	12.37
	25	37.14	7.19	44.29	9.18	51.43	11.41	55.00	12.64	55.71	12.68	56.97	12.80	58.39	12.91
	27	37.14	7.66	44.29	9.81	51.43	12.21	54.11	13.17	54.82	13.21	56.25	13.34	57.50	13.46
	29	37.14	8.17	44.29	10.47	51.43	13.05	53.39	13.71	54.11	13.77	55.36	13.89	56.79	14.01
	31	37.14	8.71	44.29	11.17	51.43	13.93	52.50	14.24	53.22	14.30	54.65	14.42	55.89	14.57
	33	37.14	9.26	44.29	11.90	51.07	14.69	51.79	14.77	52.50	14.83	53.75	14.98	55.18	15.12
	35	37.14	9.85	44.29	12.68	50.18	15.22	50.90	15.30	51.61	15.39	52.86	15.53	54.29	15.67
	37	37.14	10.49	44.29	13.50	49.46	15.77	50.18	15.84	50.72	15.92	52.15	16.08	53.39	16.22
	39	37.14	11.14	44.29	14.38	48.57	16.31	49.29	16.39	50.00	16.47	51.25	16.63	52.68	16.80
	41	37.14	11.26	44.29	14.50	48.19	16.42	48.91	16.50	49.62	16.59	50.60	16.75	51.09	16.91
	43	37.14	11.37	44.29	14.68	47.81	16.54	48.52	16.62	49.24	16.70	50.15	16.81	50.31	17.26
	45	37.14	11.74	44.29	14.76	47.33	16.69	48.01	16.82	48.80	16.85	49.64	17.27	49.84	17.66
	48	40.68	12.16	48.50	16.02	51.08	16.80	51.75	16.94	52.84	17.03	53.47	17.34	53.88	17.85
100%	-5	33.75	4.77	40.18	5.75	46.79	6.84	50.00	7.33	53.22	7.95	59.82	9.06	63.22	9.45
	-2	33.75	4.83	40.18	5.82	46.79	6.92	50.00	7.46	53.22	8.06	59.82	9.17	63.22	9.52
	0	33.75	4.88	40.18	5.88	46.79	6.99	50.00	7.55	53.22	8.13	59.82	9.32	63.22	9.62
	2	33.75	4.98	40.18	5.96	46.79	7.07	50.00	7.65	53.22	8.22	59.82	9.45	63.22	9.77
	4	33.75	5.01	40.18	6.02	46.79	7.17	50.00	7.77	53.22	8.33	59.82	9.55	63.22	9.88
	6	33.75	5.08	40.18	6.14	46.79	7.27	50.00	7.90	53.22	8.45	59.82	9.68	63.22	10.03
	8	33.75	5.18	40.18	6.23	46.79	7.40	50.00	8.00	53.22	8.59	59.82	9.83	63.22	10.20
	10	33.75	5.24	40.18	6.35	46.79	7.52	50.00	8.13	53.22	8.75	59.82	10.00	63.22	10.35
	12	33.75	5.33	40.18	6.47	46.79	7.66	50.00	8.28	53.22	8.91	59.82	10.18	62.32	10.43
	14	33.75	5.43	40.18	6.60	46.79	7.81	50.00	8.44	53.22	9.07	59.82	10.38	61.61	10.55
	16	33.75	5.53	40.18	6.72	46.79	7.97	50.00	8.60	53.22	9.26	59.47	10.51	60.72	10.67
	18	33.75	5.63	40.18	6.84	46.79	8.11	50.00	8.77	53.22	9.44	58.75	10.86	60.00	10.94
	20	33.75	5.74	40.18	6.99	46.79	8.36	50.00	9.22	53.22	10.12	57.86	11.37	59.11	11.47
	21	33.75	5.80	40.18	7.05	46.79	8.67	50.00	9.55	53.22	10.47	57.50	11.64	58.75	11.74
	23	33.75	5.94	40.18	7.52	46.79	9.28	50.00	10.22	53.22	11.23	56.79	12.17	57.86	12.27
	25	33.75	6.33	40.18	8.03	46.79	9.93	50.00	10.96	53.22	12.02	55.90	12.70	57.14	12.80
	27	33.75	6.76	40.18	8.56	46.79	10.61	50.00	11.72	53.22	12.87	55.00	13.23	56.25	13.36
	29	33.75	7.19	40.18	9.14	46.79	11.33	50.00	12.52	53.04	13.66	54.29	13.79	55.54	13.89
	31	33.75	7.66	40.18	9.75	46.79	12.09	50.00	13.36	52.32	14.20	53.40	14.32	54.64	14.44
	33	33.75	8.13	40.18	10.39	46.79	12.89	50.00	14.26	51.43	14.73	52.68	14.85	53.93	14.99
35	33.75	8.64	40.18	11.04	46.79	13.75	50.00	15.20	50.54	15.26	51.79	15.40	53.04	15.53	
37	33.75	9.20	40.18	11.76	46.79	14.65	49.10	15.73	49.82	15.81	51.07	15.96	52.15	16.08	
39	33.75	9.77	40.18	12.50	46.79	15.59	48.39	16.27	48.93	16.35	50.18	16.49	51.43	16.65	
41	33.75	10.23	40.18	12.95	46.79	16.16	47.64	16.38	48.55	16.60	49.31	16.88	50.68	17.00	
43	33.75	10.68	40.18	13.41	46.79	16.46	46.89	16.57	48.20	16.76	49.60	16.99	49.79	17.19	
45	33.75	11.29	40.18	14.02	46.79	16.74	45.89	16.80	47.95	17.06	49.18	17.25	48.79	17.41	
48	34.96	11.79	41.61	14.51	48.46	16.77	45.57	16.99	49.58	17.37	47.83	17.43	49.42	17.58	
90%	-5	30.36	4.22	36.25	5.06	42.14	5.97	45.00	6.52	47.86	6.93	53.75	7.97	59.64	9.13
	-2	30.36	4.26	36.25	5.12	42.14	6.05	45.00	6.61	47.86	7.02	53.75	8.05	59.64	9.22
	0	30.36	4.32	36.25	5.18	42.14	6.14	45.00	6.69	47.86	7.11	53.75	8.14	59.64	9.29
	2	30.36	4.39	36.25	5.25	42.14	6.21	45.00	6.79	47.86	7.22	53.75	8.31	59.64	9.43
	4	30.36	4.46	36.25	5.32	42.14	6.31	45.00	6.88	47.86	7.31	53.75	8.44	59.64	9.57
	6	30.36	4.52	36.25	5.43	42.14	6.43	45.00	7.01	47.86	7.44	53.75	8.57	59.64	9.73
	8	30.36	4.60	36.25	5.53	42.14	6.56	45.00	7.10	47.86	7.57	53.75	8.73	59.64	9.82
	10	30.36	4.69	36.25	5.65	42.14	6.68	45.00	7.21	47.86	7.74	53.75	8.84	59.64	9.98
	12	30.36	4.77	36.25	5.76	42.14	6.80	45.00	7.33	47.86	7.89	53.75	9.01	59.64	10.16
	14	30.36	4.85	36.25	5.86	42.14	6.92	45.00	7.48	47.86	8.03	53.75	9.18	59.64	10.34
	16	30.36	4.94	36.25	5.96	42.14	7.07	45.00	7.62	47.86	8.19	53.75	9.36	59.46	10.53
	18	30.36	5.02	36.25	6.08	42.14	7.19	45.00	7.76	47.86	8.36	53.75	9.55	58.75	10.86
	20	30.36	5.12	36.25	6.22	42.14	7.33	45.00	7.93	47.86	8.66	53.75	10.26	57.86	11.37
	21	30.36	5.16	36.25	6.27	42.14	7.46	45.00	8.19	47.86	8.97	53.75	10.63	57.50	11.63
23	30.36	5.26	36.25	6.51	42.14	7.99	45.00	8.79	47.86	9.63	53.75	11.41	56.61	12.17	
25	30.36	5.55	36.25	6.96	42.14	8.54	45.00	9.40	47.86	10.28	53.75	12.21	55.89	12.70	

	27	30.36	5.90	36.25	7.42	42.14	9.12	45.00	10.04	47.86	11.00	53.75	13.07	55.00	13.23
	29	30.36	6.29	36.25	7.91	42.14	9.73	45.00	10.71	47.86	11.76	53.21	13.66	54.28	13.76
	31	30.36	6.68	36.25	8.42	42.14	10.36	45.00	11.43	47.86	12.54	52.32	14.20	53.39	14.32
	33	30.36	7.09	36.25	8.95	42.14	11.06	45.00	12.19	47.86	13.38	51.61	14.75	52.68	14.85
	35	30.36	7.54	36.25	9.52	42.14	11.78	45.00	12.99	47.86	14.26	50.72	15.28	51.79	15.40
	37	30.36	7.99	36.25	10.12	42.14	12.54	45.00	13.83	47.86	15.20	49.82	15.81	51.07	15.94
	39	30.36	8.48	36.25	10.78	42.14	13.33	45.00	14.73	47.86	16.18	49.11	16.37	50.18	16.49
	41	30.36	8.77	36.25	11.26	42.14	13.82	45.00	15.12	47.86	16.28	48.77	16.78	49.84	16.88
	43	30.36	9.19	36.25	11.75	42.14	14.31	45.00	15.51	47.86	16.63	48.52	17.00	49.41	17.14
	45	30.36	9.78	36.25	12.33	42.14	14.89	45.00	16.03	47.86	17.09	48.25	17.18	48.66	17.37
	48	30.36	10.32	36.25	12.90	42.14	15.46	45.00	16.23	47.86	17.24	53.16	17.42	52.60	17.61
80%	-5	26.96	3.72	32.14	4.40	37.32	5.21	40.00	5.54	42.68	5.96	47.86	6.89	53.04	7.87
	-2	26.96	3.77	32.14	4.45	37.32	5.25	40.00	5.62	42.68	6.02	47.86	6.96	53.04	7.94
	0	26.96	3.84	32.14	4.51	37.32	5.32	40.00	5.69	42.68	6.13	47.86	7.06	53.04	8.05
	2	26.96	3.92	32.14	4.57	37.32	5.39	40.00	5.80	42.68	6.24	47.86	7.20	53.04	8.20
	4	26.96	3.98	32.14	4.65	37.32	5.49	40.00	5.93	42.68	6.34	47.86	7.33	53.04	8.31
	6	26.96	4.05	32.14	4.76	37.32	5.58	40.00	6.06	42.68	6.47	47.86	7.44	53.04	8.46
	8	26.96	4.12	32.14	4.87	37.32	5.71	40.00	6.16	42.68	6.61	47.86	7.55	53.04	8.62
	10	26.96	4.16	32.14	4.98	37.32	5.86	40.00	6.31	42.68	6.76	47.86	7.72	53.04	8.71
	12	26.96	4.22	32.14	5.06	37.32	5.96	40.00	6.43	42.68	6.90	47.86	7.87	53.04	8.87
	14	26.96	4.30	32.14	5.16	37.32	6.06	40.00	6.54	42.68	7.03	47.86	8.01	53.04	9.03
	16	26.96	4.36	32.14	5.24	37.32	6.19	40.00	6.66	42.68	7.15	47.86	8.17	53.04	9.20
	18	26.96	4.45	32.14	5.35	37.32	6.31	40.00	6.80	42.68	7.29	47.86	8.34	53.04	9.38
	20	26.96	4.53	32.14	5.45	37.32	6.43	40.00	6.92	42.68	7.44	47.86	8.65	53.04	10.04
	21	26.96	4.57	32.14	5.49	37.32	6.49	40.00	7.01	42.68	7.60	47.86	8.95	53.04	10.41
	23	26.96	4.65	32.14	5.61	37.32	6.80	40.00	7.46	42.68	8.13	47.86	9.59	53.04	11.16
	25	26.96	4.79	32.14	5.96	37.32	7.27	40.00	7.97	42.68	8.69	47.86	10.26	53.04	11.94
	27	26.96	5.10	32.14	6.35	37.32	7.74	40.00	8.50	42.68	9.28	47.86	10.96	53.04	12.78
	29	26.96	5.43	32.14	6.76	37.32	8.26	40.00	9.05	42.68	9.92	47.86	11.70	53.04	13.66
	31	26.96	5.76	32.14	7.19	37.32	8.79	40.00	9.65	42.68	10.57	47.86	12.50	52.14	14.20
	33	26.96	6.12	32.14	7.64	37.32	9.36	40.00	10.28	42.68	11.25	47.86	13.32	51.43	14.73
	35	26.96	6.49	32.14	8.13	37.32	9.96	40.00	10.94	42.68	11.98	47.86	14.20	50.54	15.26
	37	26.96	6.88	32.14	8.62	37.32	10.59	40.00	11.66	42.68	12.76	47.86	15.14	49.82	15.79
	39	26.96	7.29	32.14	9.20	37.32	11.27	40.00	12.39	42.68	13.58	47.86	16.12	48.93	16.35
	41	26.96	7.46	32.14	9.28	37.32	11.43	40.00	12.72	42.68	13.83	47.86	16.53	48.63	16.64
43	26.96	7.68	32.14	9.36	37.32	11.60	40.00	12.94	42.68	14.02	47.86	16.72	48.33	16.81	
45	26.96	7.89	32.14	9.47	37.32	11.82	40.00	13.21	42.68	14.26	47.86	16.91	47.73	17.09	
48	26.96	8.15	32.14	9.54	41.99	12.01	40.00	13.39	42.68	14.38	47.86	17.08	53.24	17.32	
70%	-5	23.57	3.32	28.21	3.89	32.68	4.41	35.00	4.73	37.32	5.05	41.79	5.78	46.43	6.64
	-2	23.57	3.35	28.21	3.91	32.68	4.44	35.00	4.82	37.32	5.14	41.79	5.87	46.43	6.73
	0	23.57	3.37	28.21	3.97	32.68	4.53	35.00	4.91	37.32	5.23	41.79	5.98	46.43	6.82
	2	23.57	3.38	28.21	3.98	32.68	4.60	35.00	5.00	37.32	5.32	41.79	6.11	46.43	6.93
	4	23.57	3.43	28.21	4.08	32.68	4.70	35.00	5.09	37.32	5.44	41.79	6.21	46.43	7.09
	6	23.57	3.48	28.21	4.15	32.68	4.82	35.00	5.26	37.32	5.57	41.79	6.32	46.43	7.23
	8	23.57	3.55	28.21	4.27	32.68	4.93	35.00	5.34	37.32	5.68	41.79	6.50	46.43	7.37
	10	23.57	3.62	28.21	4.34	32.68	5.06	35.00	5.45	37.32	5.84	41.79	6.64	46.43	7.46
	12	23.57	3.71	28.21	4.40	32.68	5.16	35.00	5.55	37.32	5.94	41.79	6.76	46.43	7.60
	14	23.57	3.77	28.21	4.49	32.68	5.24	35.00	5.63	37.32	6.04	41.79	6.88	46.43	7.74
	16	23.57	3.83	28.21	4.57	32.68	5.35	35.00	5.76	37.32	6.17	41.79	7.01	46.43	7.89
	18	23.57	3.89	28.21	4.65	32.68	5.45	35.00	5.86	37.32	6.27	41.79	7.15	46.43	8.05
	20	23.57	3.95	28.21	4.73	32.68	5.55	35.00	5.96	37.32	6.39	41.79	7.29	46.43	8.28
	21	23.57	3.99	28.21	4.77	32.68	5.59	35.00	6.02	37.32	6.45	41.79	7.40	46.43	8.56
	23	23.57	4.06	28.21	4.86	32.68	5.72	35.00	6.23	37.32	6.78	41.79	7.93	46.43	9.18
	25	23.57	4.14	28.21	5.06	32.68	6.08	35.00	6.66	37.32	7.23	41.79	8.48	46.43	9.81
	27	23.57	4.38	28.21	5.39	32.68	6.49	35.00	7.09	37.32	7.72	41.79	9.05	46.43	10.49
	29	23.57	4.65	28.21	5.72	32.68	6.90	35.00	7.56	37.32	8.22	41.79	9.65	46.43	11.21
	31	23.57	4.92	28.21	6.06	32.68	7.35	35.00	8.03	37.32	8.75	41.79	10.28	46.43	11.94
	33	23.57	5.22	28.21	6.45	32.68	7.83	35.00	8.54	37.32	9.32	41.79	10.96	46.43	12.74
	35	23.57	5.53	28.21	6.84	32.68	8.30	35.00	9.10	37.32	9.92	41.79	11.68	46.43	13.58
	37	23.57	5.84	28.21	7.25	32.68	8.83	35.00	9.65	37.32	10.55	41.79	12.43	46.43	14.46
	39	23.57	6.19	28.21	7.68	32.68	9.36	35.00	10.26	37.32	11.21	41.79	13.21	46.43	15.41
	41	23.57	6.46	28.21	7.96	32.68	9.64	35.00	10.60	37.32	11.55	41.79	13.76	46.43	16.09
43	23.57	6.99	28.21	8.50	32.68	10.03	35.00	11.17	37.32	11.89	41.79	14.26	46.43	16.59	
45	23.57	7.14	28.21	8.68	32.68	10.24	35.00	11.36	37.32	12.48	41.79	15.03	46.43	17.22	
48	23.57	7.32	28.21	8.76	32.68	10.35	35.00	11.54	37.32	12.82	41.79	15.71	46.43	17.63	

60%	-5	20.18	2.83	24.11	3.28	28.04	3.83	30.00	4.08	31.97	4.40	35.89	4.95	39.82	5.67
	-2	20.18	2.85	24.11	3.34	28.04	3.90	30.00	4.14	31.97	4.45	35.89	5.02	39.82	5.71
	0	20.18	2.89	24.11	3.38	28.04	3.95	30.00	4.19	31.97	4.52	35.89	5.09	39.82	5.78
	2	20.18	2.94	24.11	3.46	28.04	4.02	30.00	4.27	31.97	4.58	35.89	5.20	39.82	5.86
	4	20.18	3.03	24.11	3.52	28.04	4.10	30.00	4.32	31.97	4.65	35.89	5.28	39.82	5.94
	6	20.18	3.05	24.11	3.59	28.04	4.18	30.00	4.42	31.97	4.75	35.89	5.39	39.82	6.08
	8	20.18	3.11	24.11	3.65	28.04	4.26	30.00	4.50	31.97	4.84	35.89	5.49	39.82	6.18
	10	20.18	3.17	24.11	3.73	28.04	4.32	30.00	4.63	31.97	4.94	35.89	5.59	39.82	6.27
	12	20.18	3.24	24.11	3.79	28.04	4.40	30.00	4.71	31.97	5.02	35.89	5.69	39.82	6.37
	14	20.18	3.28	24.11	3.85	28.04	4.47	30.00	4.79	31.97	5.12	35.89	5.80	39.82	6.49
	16	20.18	3.32	24.11	3.91	28.04	4.55	30.00	4.88	31.97	5.20	35.89	5.90	39.82	6.62
	18	20.18	3.38	24.11	3.97	28.04	4.63	30.00	4.96	31.97	5.31	35.89	6.00	39.82	6.74
	20	20.18	3.42	24.11	4.06	28.04	4.71	30.00	5.06	31.97	5.41	35.89	6.12	39.82	6.88
	21	20.18	3.46	24.11	4.08	28.04	4.75	30.00	5.10	31.97	5.45	35.89	6.19	39.82	6.94
	23	20.18	3.50	24.11	4.16	28.04	4.83	30.00	5.20	31.97	5.55	35.89	6.43	39.82	7.39
	25	20.18	3.56	24.11	4.22	28.04	5.02	30.00	5.45	31.97	5.90	35.89	6.86	39.82	7.89
	27	20.18	3.71	24.11	4.49	28.04	5.35	30.00	5.82	31.97	6.29	35.89	7.31	39.82	8.42
	29	20.18	3.91	24.11	4.75	28.04	5.69	30.00	6.19	31.97	6.70	35.89	7.80	39.82	8.99
	31	20.18	4.16	24.11	5.04	28.04	6.04	30.00	6.57	31.97	7.13	35.89	8.30	39.82	9.56
	33	20.18	4.38	24.11	5.35	28.04	6.41	30.00	6.98	31.97	7.58	35.89	8.83	39.82	10.20
35	20.18	4.65	24.11	5.67	28.04	6.80	30.00	7.41	31.97	8.05	35.89	9.40	39.82	10.86	
37	20.18	4.92	24.11	6.00	28.04	7.21	30.00	7.87	31.97	8.54	35.89	10.00	39.82	11.55	
39	20.18	5.18	24.11	6.35	28.04	7.64	30.00	8.34	31.97	9.07	35.89	10.61	39.82	12.29	
41	20.18	5.35	24.11	6.62	28.04	7.92	30.00	8.67	31.97	9.41	35.89	11.11	39.82	12.85	
43	20.18	5.52	24.11	6.90	28.04	8.20	30.00	8.93	31.97	9.74	35.89	11.58	39.82	13.40	
45	20.18	5.78	24.11	7.25	28.04	8.53	30.00	9.26	31.97	10.22	35.89	12.10	39.82	14.14	
48	20.18	5.99	24.11	7.57	28.04	8.82	30.00	9.50	31.97	10.61	35.89	12.54	39.82	14.81	
50%	-5	16.88	2.46	20.18	2.84	23.39	3.27	25.00	3.42	26.61	3.61	29.82	4.11	33.22	4.42
	-2	16.88	2.48	20.18	2.90	23.39	3.30	25.00	3.47	26.61	3.68	29.82	4.16	33.22	4.48
	0	16.88	2.52	20.18	2.95	23.39	3.36	25.00	3.52	26.61	3.72	29.82	4.23	33.22	4.56
	2	16.88	2.55	20.18	2.99	23.39	3.42	25.00	3.57	26.61	3.78	29.82	4.25	33.22	4.65
	4	16.88	2.58	20.18	3.04	23.39	3.46	25.00	3.61	26.61	3.86	29.82	4.35	33.22	4.77
	6	16.88	2.63	20.18	3.09	23.39	3.51	25.00	3.69	26.61	3.93	29.82	4.42	33.22	4.91
	8	16.88	2.69	20.18	3.14	23.39	3.57	25.00	3.78	26.61	3.98	29.82	4.49	33.22	5.07
	10	16.88	2.74	20.18	3.17	23.39	3.63	25.00	3.83	26.61	4.10	29.82	4.61	33.22	5.14
	12	16.88	2.77	20.18	3.22	23.39	3.69	25.00	3.91	26.61	4.18	29.82	4.69	33.22	5.22
	14	16.88	2.81	20.18	3.26	23.39	3.73	25.00	3.99	26.61	4.24	29.82	4.77	33.22	5.33
	16	16.88	2.85	20.18	3.30	23.39	3.79	25.00	4.06	26.61	4.30	29.82	4.85	33.22	5.41
	18	16.88	2.89	20.18	3.36	23.39	3.85	25.00	4.12	26.61	4.38	29.82	4.94	33.22	5.51
	20	16.88	2.93	20.18	3.40	23.39	3.91	25.00	4.18	26.61	4.47	29.82	5.02	33.22	5.61
	21	16.88	2.95	20.18	3.44	23.39	3.95	25.00	4.22	26.61	4.51	29.82	5.08	33.22	5.67
	23	16.88	2.99	20.18	3.48	23.39	4.01	25.00	4.30	26.61	4.59	29.82	5.16	33.22	5.80
	25	16.88	3.03	20.18	3.54	23.39	4.10	25.00	4.38	26.61	4.73	29.82	5.43	33.22	6.19
	27	16.88	3.09	20.18	3.69	23.39	4.32	25.00	4.67	26.61	5.02	29.82	5.78	33.22	6.60
	29	16.88	3.26	20.18	3.89	23.39	4.59	25.00	4.96	26.61	5.35	29.82	6.15	33.22	7.03
	31	16.88	3.44	20.18	4.12	23.39	4.85	25.00	5.26	26.61	5.67	29.82	6.53	33.22	7.48
	33	16.88	3.65	20.18	4.36	23.39	5.16	25.00	5.57	26.61	6.02	29.82	6.94	33.22	7.95
35	16.88	3.85	20.18	4.61	23.39	5.45	25.00	5.90	26.61	6.37	29.82	7.37	33.22	8.44	
37	16.88	4.06	20.18	4.88	23.39	5.78	25.00	6.25	26.61	6.76	29.82	7.82	33.22	8.97	
39	16.88	4.28	20.18	5.14	23.39	6.10	25.00	6.62	26.61	7.17	29.82	8.30	33.22	9.52	
41	16.88	4.46	20.18	5.36	23.39	6.33	25.00	6.93	26.61	7.48	29.82	8.74	33.22	9.97	
43	16.88	4.75	20.18	5.73	23.39	6.55	25.00	7.24	26.61	7.67	29.82	9.18	33.22	10.41	
45	16.88	4.86	20.18	5.88	23.39	6.99	25.00	7.80	26.61	8.00	29.82	10.07	33.22	11.29	
48	16.88	4.98	20.18	6.04	23.39	7.40	25.00	8.29	26.61	8.35	29.82	10.88	33.22	12.15	

18HP heating mode

Combination (Capacity index)	Outdoor air temp.		Indoor temperature(°C DB)											
			16		18		20		21		22		24	
	°C DB	°C	TC	PI	TC	PI	TC	PI	TC	PI	TC	PI	TC	PI
130%	-19.8	-20	36.26	10.07	36.09	10.77	35.91	11.49	35.91	11.84	35.73	12.20	35.73	12.92
	-18.8	-19	36.80	10.29	36.62	10.99	36.62	11.70	36.44	12.05	36.44	12.38	36.26	13.08
	-16.7	-17	38.22	10.77	38.04	11.44	37.86	12.12	37.86	12.45	37.86	12.79	37.69	13.45
	-13.7	-15	39.82	11.27	39.65	11.92	39.47	12.57	39.47	12.88	39.29	13.21	39.29	13.86
	-11.8	-13	41.42	11.77	41.42	12.40	41.24	13.01	41.07	13.32	41.07	13.64	40.89	14.25
	-9.8	-11	43.38	12.29	43.20	12.88	43.02	13.47	43.02	13.77	43.02	14.06	42.84	14.66
	-9.5	-10	44.44	12.55	44.27	13.12	44.09	13.69	44.09	13.99	43.91	14.27	43.91	14.84
	-8.5	-9.1	45.33	12.77	45.16	13.32	45.16	13.90	44.98	14.18	44.98	14.45	44.80	15.03
	-7	-7.6	46.93	13.14	46.93	13.69	46.75	14.23	46.75	14.51	46.58	14.77	46.40	15.32
	-5	-5.6	49.42	13.64	49.24	14.16	49.06	14.68	49.06	14.93	48.89	15.17	48.89	15.69
	-3	-3.7	51.73	14.08	51.56	14.58	51.56	15.06	51.38	15.32	51.38	15.56	51.20	16.04
	0	-0.7	55.82	14.77	55.82	15.23	55.64	15.67	55.64	15.84	55.47	16.14	55.47	16.58
	3	2.2	60.26	15.38	60.09	15.80	59.91	16.23	59.91	16.43	59.91	16.66	59.73	17.06
	5	4.1	63.29	15.77	63.11	16.17	63.11	16.56	62.93	16.77	62.93	16.97	62.76	17.36
	7	6	66.49	16.14	66.31	16.51	66.31	16.90	66.13	17.08	66.13	17.27	63.46	16.58
9	7.9	69.86	16.47	69.68	16.84	69.68	17.19	69.51	17.38	68.09	17.01	63.46	15.58	
11	9.8	73.42	16.80	73.25	17.14	72.89	17.36	70.40	16.67	68.09	15.99	63.46	14.68	
13	11.8	77.33	17.12	77.15	17.45	72.89	16.27	70.40	15.62	68.09	15.01	63.46	13.77	
15	13.7	81.06	17.41	77.51	16.53	72.89	15.32	70.40	14.73	68.09	14.14	63.46	12.99	
120%	-19.8	-20	36.09	11.03	35.91	11.68	35.73	12.34	35.73	12.66	35.73	12.99	35.55	13.66
	-18.8	-19	36.63	11.23	36.45	11.88	36.45	12.53	36.27	12.84	36.27	13.18	36.09	13.82
	-16.7	-17	38.05	11.68	37.87	12.31	37.63	12.92	37.69	13.23	37.69	13.55	37.51	14.16
	-13.7	-15	39.65	12.14	39.47	12.73	39.29	13.32	39.29	13.64	39.29	13.94	39.11	14.53
	-11.8	-13	41.25	12.60	41.25	13.18	41.07	13.75	41.07	14.05	40.89	14.32	40.89	14.90
	-9.8	-11	43.20	13.08	43.02	13.62	43.02	14.18	42.84	14.45	42.84	14.71	42.67	15.27
	-9.5	-10	44.27	13.32	44.09	13.86	43.91	14.38	43.91	14.66	43.91	14.92	43.74	15.45
	-8.5	-9.1	45.16	13.53	44.98	14.05	44.98	14.56	44.80	14.82	44.80	15.10	44.62	15.62
	-7	-7.6	46.76	13.88	46.76	14.38	46.58	14.88	46.58	15.14	46.40	15.38	46.40	15.88
	-5	-5.6	49.24	14.32	49.07	14.81	48.89	15.29	48.89	15.53	48.89	15.77	48.72	16.23
	-3	-3.7	51.56	14.75	51.56	15.21	51.38	15.66	51.38	15.88	51.20	16.12	51.20	16.56
	0	-0.7	55.65	15.38	55.65	15.80	55.47	16.21	55.47	16.44	55.29	16.64	55.29	17.06
	3	2.2	60.09	15.95	59.91	16.34	59.91	16.73	59.73	16.93	59.73	17.12	58.49	17.03
	5	4.1	63.11	16.30	62.94	16.67	62.94	17.04	62.76	17.23	62.76	17.42	58.49	15.99
	7	6	66.31	16.64	66.31	16.99	66.14	17.34	65.07	17.10	62.94	16.40	58.49	15.05
9	7.9	69.69	16.97	69.52	17.30	67.20	16.73	65.07	16.07	62.94	15.42	58.49	14.16	
11	9.8	73.25	17.27	71.47	16.97	67.20	15.73	65.07	15.12	62.94	14.51	58.49	13.34	
13	11.8	75.91	17.10	71.47	15.92	67.20	14.75	65.07	14.20	62.94	13.64	58.49	12.55	
15	13.7	75.91	16.10	71.47	14.99	67.20	13.92	65.07	13.38	62.94	12.86	58.49	11.84	
110%	-19.8	-20	35.91	11.99	35.74	12.58	35.56	13.19	35.56	13.49	35.57	13.79	35.38	14.40
	-18.8	-19	36.45	12.18	36.27	12.77	36.27	13.36	36.27	13.66	36.09	13.95	36.09	14.55
	-16.7	-17	37.87	12.58	37.69	13.16	38.22	13.73	37.51	14.01	37.51	14.31	37.33	14.86
	-13.7	-15	39.47	13.01	39.30	13.57	39.11	14.10	39.11	14.38	39.11	14.66	38.93	15.19
	-11.8	-13	41.07	13.45	41.07	13.97	40.89	14.49	40.89	14.75	40.71	15.01	40.71	15.55
	-9.8	-11	43.02	13.88	42.84	14.38	42.84	14.88	42.66	15.14	42.66	15.38	42.66	15.88
	-9.5	-10	44.09	14.10	43.91	14.58	43.73	15.08	43.73	15.32	43.73	15.56	43.56	16.05
	-8.5	-9.1	44.98	14.29	44.80	14.77	44.80	15.25	44.62	15.49	44.62	15.73	44.62	14.34
	-7	-7.6	46.58	14.62	46.58	15.06	46.40	15.53	46.40	15.77	46.40	15.99	46.22	16.45
	-5	-5.6	49.07	15.03	48.89	15.47	48.71	15.90	48.71	16.12	48.71	16.34	48.53	16.79
	-3	-3.7	51.38	15.42	51.38	15.82	51.20	16.25	51.20	16.45	51.02	16.66	51.02	17.08
	0	-0.7	55.47	15.99	55.47	16.38	55.29	16.77	55.29	16.95	55.29	17.16	53.69	16.82
	3	2.2	59.91	16.53	59.73	16.88	59.73	17.23	59.56	17.40	57.60	16.69	53.69	15.31
	5	4.1	62.94	16.84	62.94	17.19	61.69	17.03	59.56	16.34	57.60	15.69	53.69	14.40
	7	6	66.13	17.16	65.60	17.27	61.69	15.99	59.56	15.36	57.60	14.75	53.69	13.55
9	7.9	69.51	17.43	65.60	16.23	61.69	15.04	59.56	14.45	57.60	13.88	53.69	12.77	
11	9.8	69.51	16.40	65.60	15.27	61.69	14.16	59.56	13.62	57.60	13.08	53.69	12.05	
13	11.8	69.51	15.38	65.60	14.32	61.69	13.31	59.56	12.81	57.60	12.31	53.69	11.34	
15	13.7	69.51	13.66	65.60	13.51	61.69	12.57	59.56	12.09	57.60	11.64	53.69	10.73	
100%	-19.8	-20	35.73	12.95	35.55	13.49	35.55	14.05	35.38	14.32	35.38	14.58	35.20	15.14
	-18.8	-19	36.27	13.12	36.27	13.66	36.09	14.19	36.09	14.47	35.91	14.75	35.91	15.29
	-16.7	-17	37.69	13.49	37.51	14.01	37.51	14.53	37.34	14.79	37.34	15.05	37.34	15.56

	-13.7	-15	39.29	13.88	39.11	14.38	38.93	14.88	38.93	15.14	38.93	15.38	38.76	15.88
	-11.8	-13	40.89	14.29	40.89	14.75	40.71	15.23	40.71	15.47	40.71	15.71	40.53	16.19
	-9.8	-11	42.85	14.68	42.67	15.14	42.67	15.58	42.67	15.82	42.49	16.05	42.49	16.49
	-9.5	-10	43.91	14.88	43.74	15.32	43.74	15.77	43.56	15.99	43.56	16.21	43.38	16.66
	-8.5	-9.1	44.80	15.05	44.62	15.49	44.62	15.92	44.62	16.14	44.45	16.36	44.45	16.79
	-7	-7.6	46.40	15.34	46.40	15.77	46.22	16.18	46.22	16.40	46.22	16.60	46.04	17.03
	-5	-5.6	48.89	15.73	48.71	16.12	48.71	16.53	48.54	16.71	48.54	16.91	48.36	17.32
	-3	-3.7	51.20	16.08	51.20	14.60	51.02	16.84	51.02	17.03	51.02	17.21	48.89	16.49
	0	-0.7	55.29	16.60	55.29	16.95	55.11	17.30	54.22	17.03	52.44	16.32	48.89	14.97
	3	2.2	59.74	17.08	59.56	17.40	56.00	16.10	54.22	15.47	52.44	14.86	48.89	13.64
	5	4.1	62.75	17.40	59.56	16.34	56.00	15.14	54.22	14.56	52.44	13.99	48.89	12.86
	7	6	63.11	16.51	59.56	15.36	56.00	14.25	54.22	13.71	52.44	13.18	48.89	12.12
	9	7.9	63.11	15.51	59.56	14.45	56.00	13.42	54.22	12.75	52.44	12.42	48.89	11.44
	11	9.8	63.11	14.60	59.56	13.62	56.00	12.66	54.22	12.18	52.44	11.71	48.89	10.81
	13	11.8	63.11	13.71	59.56	12.81	56.00	11.92	54.22	11.47	52.44	11.05	48.89	10.20
	15	13.7	63.11	12.94	59.56	12.09	56.00	11.25	54.22	10.84	52.44	10.44	48.89	9.66
90%	-19.8	-20	35.49	13.92	35.32	14.40	35.32	14.90	35.14	15.14	35.14	15.40	35.14	15.88
	-18.8	-19	36.03	14.06	36.03	14.56	35.85	15.05	35.85	15.29	35.85	15.53	35.67	16.01
	-16.7	-17	37.45	14.42	37.27	14.88	37.27	15.34	37.27	15.58	37.09	15.80	37.09	16.27
	-13.7	-15	39.04	14.77	38.86	15.21	38.86	15.66	38.69	15.88	38.69	16.10	38.69	16.54
	-11.8	-13	40.64	15.12	40.64	15.55	40.46	15.97	40.46	16.19	40.46	16.40	40.28	16.82
	-9.8	-11	42.59	15.47	42.59	15.88	42.41	16.29	42.41	16.49	42.41	16.71	42.24	17.12
	-9.5	-10	43.66	15.66	43.48	16.06	43.48	16.45	43.30	16.66	43.30	16.86	43.30	17.25
	-8.5	-9.1	44.54	15.82	44.54	16.21	44.37	16.60	44.37	16.78	44.37	16.99	43.83	17.15
	-7	-7.6	46.14	16.08	46.14	16.45	45.96	16.84	45.96	17.03	45.96	17.21	43.83	16.38
	-5	-5.6	48.63	16.43	48.45	16.78	48.45	17.14	48.27	17.32	47.03	16.78	43.83	15.40
	-3	-3.7	50.93	16.75	50.93	17.08	50.40	17.15	48.63	16.47	47.03	15.80	43.83	14.51
	0	-0.7	55.19	17.23	53.60	16.80	50.40	15.56	48.63	14.95	47.03	14.36	43.83	13.19
	3	2.2	56.79	16.41	53.60	15.29	50.40	14.18	48.63	13.64	47.03	13.10	43.83	12.07
	5	4.1	56.79	15.43	53.60	14.38	50.40	13.36	48.63	12.84	47.03	12.36	43.83	11.38
	7	6	56.79	14.51	53.60	13.55	50.40	12.58	48.63	12.12	47.03	11.66	43.83	10.75
9	7.9	56.79	13.68	53.60	12.75	50.40	11.86	48.63	11.44	47.03	11.01	43.83	10.16	
11	9.8	56.79	12.88	53.60	12.03	50.40	11.22	48.63	10.81	47.03	10.40	43.83	9.62	
13	11.8	56.79	12.12	53.60	11.34	50.40	10.57	48.63	10.20	47.03	9.83	43.83	9.09	
15	13.7	56.79	11.46	53.60	10.72	50.40	10.01	48.63	9.66	47.03	9.31	43.83	8.62	
80%	-19.8	-20	35.38	14.88	35.20	15.30	35.20	15.75	35.20	15.97	35.02	16.19	35.02	16.62
	-18.8	-19	35.91	15.01	35.91	15.45	35.73	15.88	35.73	16.10	35.73	16.30	35.56	16.75
	-16.7	-17	37.33	15.32	37.16	15.73	37.16	16.16	37.16	16.36	37.16	16.56	36.98	16.97
	-13.7	-15	38.93	15.64	38.76	16.03	38.76	16.43	38.76	16.62	38.58	16.82	38.58	17.23
	-11.8	-13	40.54	15.95	40.54	16.34	40.36	16.71	40.36	16.90	40.36	17.10	39.11	16.64
	-9.8	-11	42.49	16.27	42.49	16.64	42.31	17.01	42.31	17.17	41.96	17.14	39.11	15.71
	-9.5	-10	43.55	16.43	43.37	16.78	43.38	17.14	43.38	17.32	41.96	16.64	39.11	15.25
	-8.5	-9.1	44.45	16.58	44.31	16.93	44.27	17.27	43.38	16.88	41.96	16.19	39.11	14.84
	-7	-7.6	46.05	16.82	46.05	17.15	44.80	16.78	43.38	16.12	41.96	15.47	39.11	14.19
	-5	-5.6	48.53	17.12	47.64	17.03	44.80	15.77	43.38	15.16	41.96	14.55	39.11	13.36
	-3	-3.7	50.49	17.21	47.64	16.03	44.80	14.84	43.38	14.29	41.96	13.71	39.11	12.62
	0	-0.7	50.49	15.62	47.64	14.55	44.80	13.51	43.38	13.01	41.96	12.49	39.11	11.51
	3	2.2	50.49	14.23	47.64	13.27	44.80	12.34	43.38	11.88	41.96	11.44	39.11	10.55
	5	4.1	50.49	13.40	47.64	12.51	44.80	11.64	43.38	11.21	41.96	10.81	39.11	9.97
	7	6	50.49	12.62	47.64	11.81	44.80	10.99	43.38	10.60	41.96	10.22	39.11	9.44
9	7.9	50.49	11.92	47.64	11.14	44.80	10.38	43.38	10.01	41.96	9.66	39.11	8.94	
11	9.8	50.49	11.25	47.64	10.53	44.80	9.83	43.38	9.48	41.96	9.14	39.11	8.48	
13	11.8	50.49	10.60	47.64	9.94	44.80	9.29	43.38	8.96	41.96	8.64	39.11	8.01	
15	13.7	50.49	10.03	47.64	9.42	44.80	8.81	43.38	8.49	41.96	8.20	39.11	7.62	
70%	-19.8	-20	35.12	15.84	34.94	16.21	34.94	16.60	34.94	16.78	34.94	16.99	34.06	16.80
	-18.8	-19	35.65	15.97	35.65	16.34	35.48	16.71	35.48	16.90	35.48	17.10	34.06	16.45
	-16.7	-17	37.07	16.23	37.07	16.60	36.90	16.95	36.90	17.14	36.54	15.27	34.06	15.69
	-13.7	-15	38.67	16.51	38.49	16.86	38.49	17.21	37.78	16.95	36.54	16.27	34.06	14.92
	-11.8	-13	40.26	16.78	40.26	17.12	39.20	16.71	37.78	16.06	36.54	15.42	34.06	14.14
	-9.8	-11	42.21	17.06	41.68	17.04	39.20	15.79	37.78	15.17	36.54	14.56	34.06	13.38
	-9.5	-10	43.28	17.21	41.68	16.54	39.20	15.32	37.78	14.73	36.54	14.16	34.06	13.01
	-8.5	-9.1	44.17	17.30	41.68	16.10	39.20	14.92	37.78	14.34	36.54	13.79	34.06	12.68
	-7	-7.6	44.17	16.53	41.68	15.38	39.20	14.27	37.78	13.73	36.54	13.19	34.06	12.14
-5	-5.6	44.17	15.53	41.68	14.47	39.20	13.44	37.78	12.92	36.54	15.26	34.06	11.46	
-3	-3.7	44.17	14.62	41.68	13.64	39.20	12.68	37.78	12.20	36.54	11.73	34.06	10.83	

	0	-0.7	44.17	13.31	41.68	12.44	39.20	11.57	37.78	11.14	36.54	10.73	34.06	9.92
	3	2.2	44.17	12.16	41.68	11.38	39.20	10.60	37.78	10.21	36.54	9.84	34.06	9.10
	5	4.1	44.17	11.47	41.68	10.73	39.20	10.03	37.78	9.66	36.54	9.31	34.06	8.62
	7	6	44.17	10.84	41.68	10.16	39.20	9.47	37.78	9.14	36.54	8.83	34.06	8.18
	9	7.9	44.17	10.25	41.68	9.60	39.20	8.98	37.78	8.66	36.54	8.36	34.06	7.75
	11	9.8	44.17	9.70	41.68	9.09	39.20	8.51	37.78	8.22	36.54	7.94	34.06	7.36
	13	11.8	44.17	9.16	41.68	8.61	39.20	8.05	37.78	7.79	36.54	7.51	34.06	7.00
	15	13.7	44.17	8.68	41.68	8.16	39.20	7.64	37.78	7.40	36.54	7.14	34.06	6.66
60%	-19.8	-20	35.02	16.80	34.84	17.12	33.60	16.47	32.53	15.82	31.47	15.19	29.33	13.93
	-18.8	-19	35.56	16.91	35.56	17.23	33.60	16.12	32.53	15.49	31.47	14.86	29.33	13.64
	-16.7	-17	36.98	17.14	35.73	16.60	33.60	15.38	32.53	14.79	31.47	14.19	29.33	13.05
	-13.7	-15	37.87	16.95	35.73	15.77	33.60	14.62	32.53	14.06	31.47	13.51	29.33	12.42
	-11.8	-13	37.87	16.04	35.73	14.93	33.60	13.86	32.53	13.34	31.47	12.82	29.33	11.86
	-9.8	-11	37.87	15.16	35.73	14.12	33.60	13.12	32.53	12.62	31.47	12.14	29.33	11.20
	-9.5	-10	37.87	14.73	35.73	13.73	33.60	12.75	32.53	12.29	31.47	11.81	29.33	10.88
	-8.5	-9.1	37.87	14.34	35.73	13.38	33.60	12.44	32.53	11.97	31.47	11.51	29.33	10.62
	-7	-7.6	37.87	13.71	35.73	12.81	33.60	11.90	32.53	11.47	31.47	11.03	29.33	10.20
	-5	-5.6	37.87	12.92	35.73	12.07	33.60	11.23	32.53	10.83	31.47	10.42	29.33	9.64
	-3	-3.7	37.87	12.19	35.73	11.40	33.60	10.62	32.53	10.25	31.47	9.86	29.33	9.12
	0	-0.7	37.87	11.14	35.73	10.44	33.60	9.73	32.53	9.40	31.47	9.05	29.33	8.38
	3	2.2	37.87	10.22	35.73	9.59	33.60	8.96	32.53	8.64	31.47	8.35	29.33	7.73
	5	4.1	37.87	9.66	35.73	9.07	33.60	8.48	32.53	8.20	31.47	7.90	29.33	7.35
	7	6	37.87	9.14	35.73	8.59	33.60	8.03	32.53	7.77	31.47	7.51	29.33	6.98
	9	7.9	37.87	8.66	35.73	8.14	33.60	7.62	32.53	7.38	31.47	7.12	29.33	6.64
11	9.8	37.87	8.22	35.73	7.73	33.60	7.25	32.53	7.01	31.47	6.77	29.33	6.33	
13	11.8	37.87	7.77	35.73	7.33	33.60	6.88	32.53	6.66	31.47	6.44	29.33	6.01	
15	13.7	37.87	7.40	35.73	6.96	33.60	6.55	32.53	6.35	31.47	6.14	29.33	5.74	
50%	-19.8	-20	31.54	15.29	29.77	14.23	28.00	13.21	26.94	12.73	26.05	12.23	24.28	11.27
	-18.8	-19	31.54	14.95	29.77	13.93	28.00	12.95	26.94	12.45	26.05	11.97	24.28	11.05
	-16.7	-17	31.54	14.27	29.77	13.31	28.00	12.38	26.94	11.92	26.05	11.47	24.28	10.59
	-13.7	-15	31.54	13.58	29.77	12.68	28.00	11.79	26.94	11.36	26.05	10.94	24.28	10.10
	-11.8	-13	31.54	12.90	29.77	12.05	28.00	11.21	26.94	10.81	26.05	10.40	24.28	9.62
	-9.8	-11	31.54	12.21	29.77	11.42	28.00	10.64	26.94	10.25	26.05	9.88	24.28	9.14
	-9.5	-10	31.54	11.88	29.77	11.10	28.00	10.36	26.94	9.99	26.05	9.62	24.28	8.90
	-8.5	-9.1	31.54	11.58	29.77	10.84	28.00	10.10	26.94	9.75	26.05	9.40	24.28	8.70
	-7	-7.6	31.54	11.10	29.77	10.40	28.00	9.70	26.94	9.36	26.05	9.03	24.28	8.36
	-5	-5.6	31.54	10.47	29.77	9.83	28.00	9.18	26.94	8.86	26.05	8.55	24.28	7.92
	-3	-3.7	31.54	9.92	29.77	9.31	28.00	8.70	26.94	8.40	26.05	8.11	24.28	7.53
	0	-0.7	31.54	9.10	29.77	8.55	28.00	8.01	26.94	7.74	26.05	7.48	24.28	6.96
	3	2.2	31.54	8.38	29.77	7.88	28.00	7.38	26.94	7.14	26.05	6.90	24.28	6.44
	5	4.1	31.54	7.96	29.77	7.48	28.00	7.01	26.94	6.79	26.05	6.57	24.28	6.13
	7	6	31.54	7.55	29.77	7.11	28.00	6.68	26.94	6.46	26.05	6.25	24.28	5.85
	9	7.9	31.54	7.16	29.77	6.75	28.00	6.35	26.94	6.16	26.05	5.96	24.28	5.57
11	9.8	31.54	6.81	29.77	6.42	28.00	6.05	26.94	5.87	26.05	5.68	24.28	5.31	
13	11.8	31.54	6.48	29.77	6.11	28.00	5.76	26.94	5.59	26.05	5.40	24.28	5.07	
15	13.7	31.54	6.16	29.77	5.83	28.00	5.50	26.94	5.33	26.05	5.16	24.28	4.85	

Note:

1. [shaded] is shown as reference.
2. The above table shows the average value of conditions may operate.
3. It is recommended to connect less than 130%.

8. Sound Levels

Standard of testing

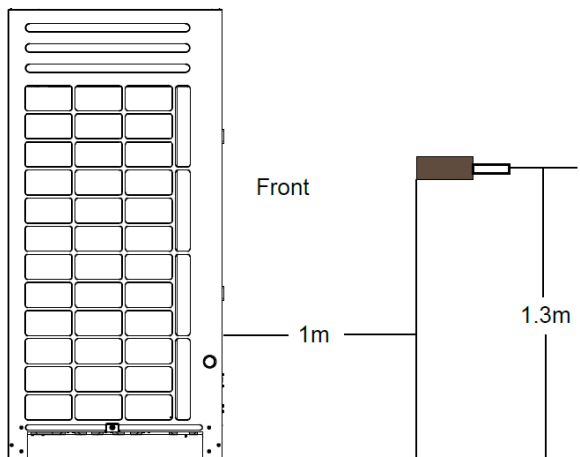

Test value

Outdoor unit (HP)	Sound pressure level (dB(A))
8	57
10	57
12	59
14	60
16	60
18	61

Sound Curve:

8,10 HP

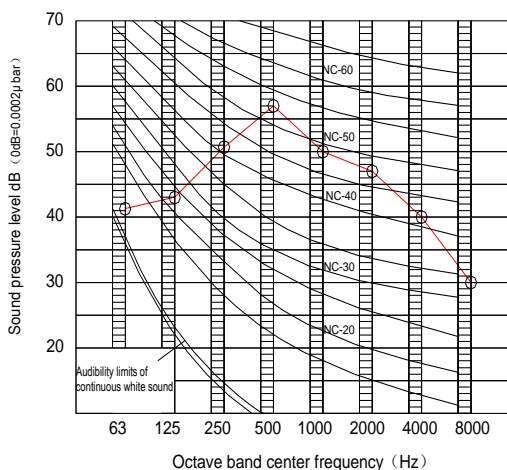

12 HP

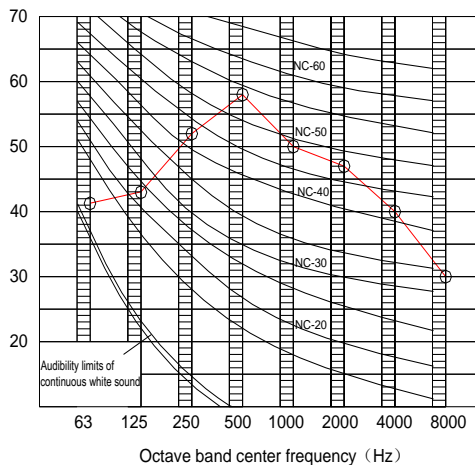

14,16 HP

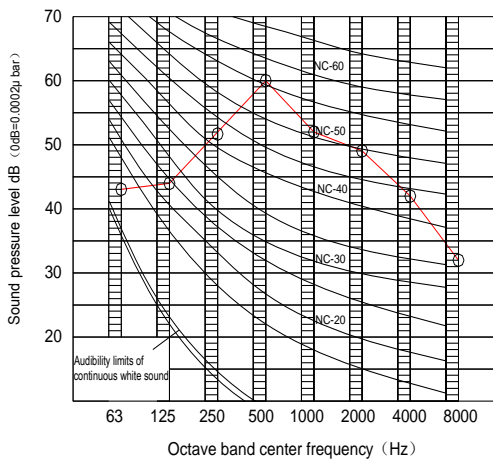

18 HP

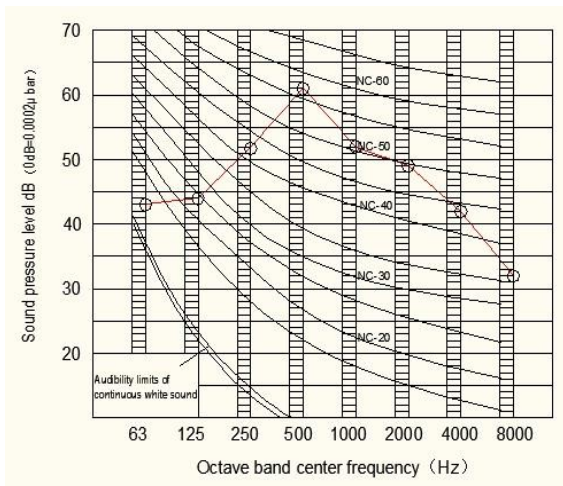

9. Accessories

9.1 Standard accessories

No	Name	Quantity	Purpose
1	Installation manual of outdoor unit	1	/
2	Operation manual of outdoor unit	1+1	(Be sure to deliver it to the customer)
3	Operation manual of indoor unit	1+1	(Be sure to deliver it to the customer)
4	Screw bag	1	Spare
5	Straight screwdriver	1	Dialing
6	Gauge joint	1	For airtight test
7	90° elbow	2	Pipe connecting

9.2 Optional accessories

Optional accessories	Model name	Packing Size (mm)	Gross Weight (kg)	Function
Branch Joint of outdoor side	FQZHW-02N1D	255×150×185	1.5	Distribute the refrigerant to indoor units and balance the resistance between each outdoor unit.
	FQZHW-03N1D	345×160×285	3.4	
	FQZHW-04N1D	475×165×300	4.8	
Branch Joint of indoor side	FQZHN-01D	290×105×100	0.4	
	FQZHN-02D	290×105×100	0.6	
	FQZHN-03D	310×130×125	0.9	
	FQZHN-04D	350×180×170	1.5	
	FQZHN-05D	365×195×215	1.9	
	FQZHN-06D	390×230×255	3.1	

Optional accessories	Model name	Function
Outdoor controller	MD-CCM02/E	Monitor the outdoor operating parameter
Three phase electricity power protector	202301600580 DPA51CM44 or 202300800224 HWUA/DPB71CM48	To stop the air-conditioner running in case of bad power supply such as Phase Error, Over-voltage, Under-voltage lose, phase lost and phase sequence inverse. Thus to protect the equipment.
Digital ammeter (WHM)	DTS634/DT636	Electricity charge monitor

8. Sound Levels

Standard of testing

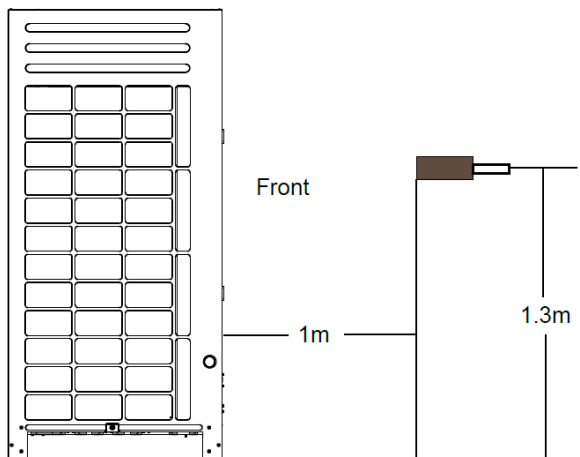

Test value

Outdoor unit (HP)	Sound pressure level (dB(A))
8	57
10	57
12	59
14	60
16	60
18	61

Sound Curve:

8,10 HP

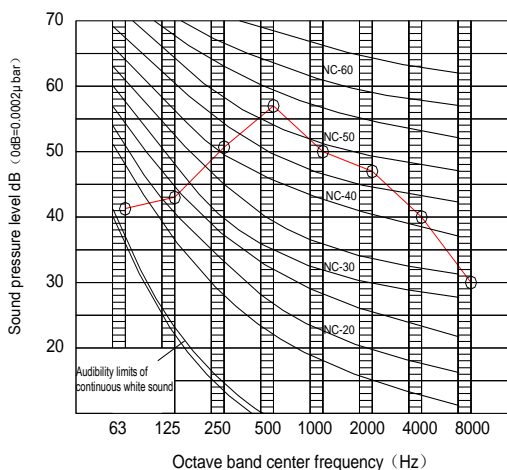

12 HP

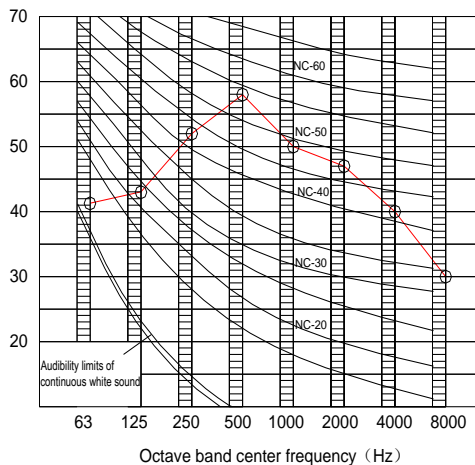

14,16 HP

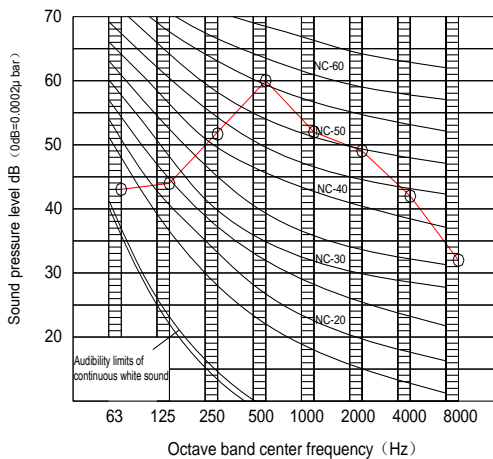

18 HP

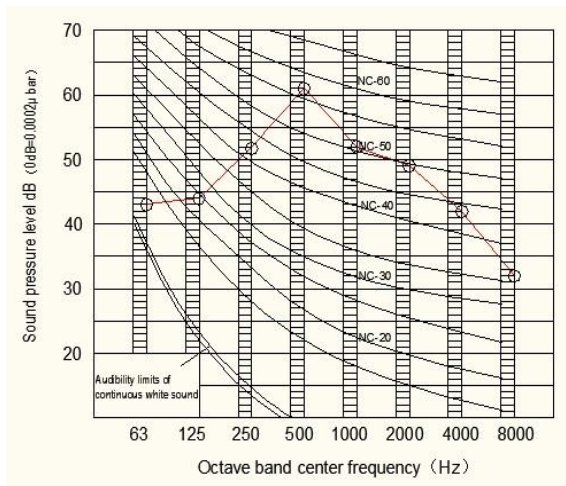

9. Accessories

9.1 Standard accessories

No	Name	Quantity	Purpose
1	Installation manual of outdoor unit	1	/
2	Operation manual of outdoor unit	1+1	(Be sure to deliver it to the customer)
3	Operation manual of indoor unit	1+1	(Be sure to deliver it to the customer)
4	Screw bag	1	Spare
5	Straight screwdriver	1	Dialing
6	Gauge joint	1	For airtight test
7	90° elbow	2	Pipe connecting

9.2 Optional accessories

Optional accessories	Model name	Packing Size (mm)	Gross Weight (kg)	Function
Branch Joint of outdoor side	FQZHW-02N1D	255×150×185	1.5	Distribute the refrigerant to indoor units and balance the resistance between each outdoor unit.
	FQZHW-03N1D	345×160×285	3.4	
	FQZHW-04N1D	475×165×300	4.8	
Branch Joint of indoor side	FQZHN-01D	290×105×100	0.4	
	FQZHN-02D	290×105×100	0.6	
	FQZHN-03D	310×130×125	0.9	
	FQZHN-04D	350×180×170	1.5	
	FQZHN-05D	365×195×215	1.9	
	FQZHN-06D	390×230×255	3.1	

Optional accessories	Model name	Function
Outdoor controller	MD-CCM02/E	Monitor the outdoor operating parameter
Three phase electricity power protector	202301600580 DPA51CM44 or 202300800224 HWUA/DPB71CM48	To stop the air-conditioner running in case of bad power supply such as Phase Error, Over-voltage, Under-voltage lose, phase lost and phase sequence inverse. Thus to protect the equipment.
Digital ammeter (WHM)	DTS634/DT636	Electricity charge monitor

Part 4 Installation

- 1.Installation Introduction2**
- 2.Units Installation 18**
 - 2.1. Installation of Indoor Unit..... 18
 - 2.2. Installation of Outdoor Unit 18
- 3.Refrigerant Pipe Engineering25**
 - 3.1. Refrigerant Pipe Processing25
 - 3.2. Air Tight Test.....34
 - 3.3. Vacuum Drying36
 - 3.4. Recharge Refrigerant38
- 4.Drainage Pipe Engineering.....39**
- 5.Duct Engineering44**
- 6.Heat Insulation Engineering.....46**
- 7.Electrical Engineering.....49**
- 8.Commissioning51**

Part 4
Installation

1. Installation Introduction

1.1 Select the Refrigerant Piping for V4+ K series modular type

1.1.1 Length and level difference permitted of the refrigerant piping

Table 4-1

Item		Permitted length	Pipe
Pipe length	Total pipe length(actual length)	$\leq 1000\text{m}$	$L_1+(L_2+L_3+L_4+L_5+L_6+L_7+L_8+L_9)\times 2+a+b+c+d+e+f+g+h+i+j$
	Farthest pipe length	Actual length	$\leq 175\text{m}$
		Equivalent length	$\leq 200\text{m}$
Equivalent length of pipe from the first branch to the farthest one		$\leq 40\text{m}/90\text{m}^*$	$L_5+L_8+L_9+j$ (Please refer to note 5)
Level difference	Level difference between indoor unit and outdoor unit	Outdoor unit up	$\leq 70\text{m}$
		Outdoor unit down	$\leq 110\text{m}$
	Level difference between indoor unit and indoor unit		$\leq 30\text{m}$

Fig.4-1

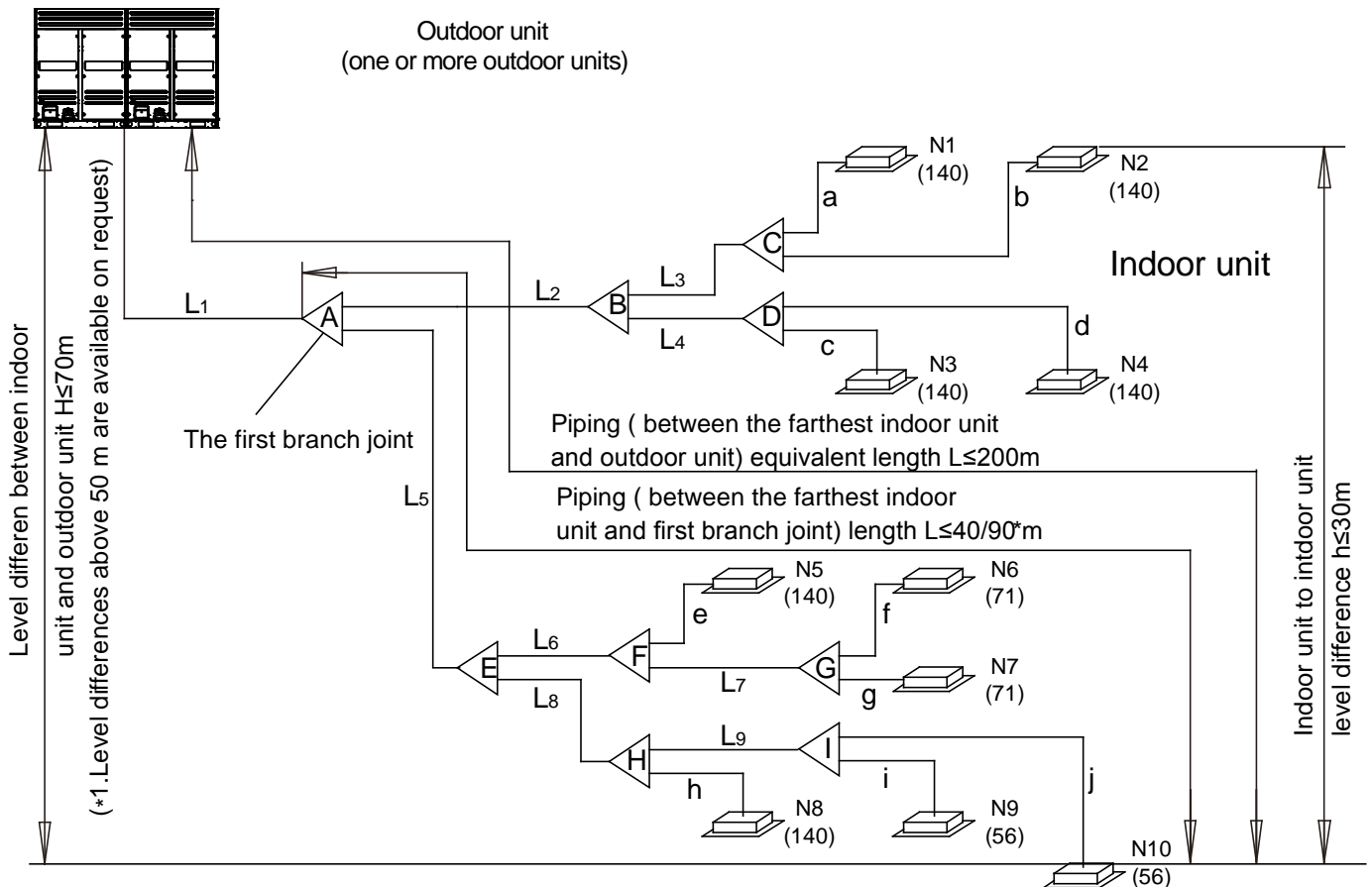

Note:

1. The equivalent length of the each branch joint is 0.5m. All branches must be purchased from Midea, otherwise system is induced to malfunction

2. The indoor units should as equal as possible to be installed in the both sides of the U-shape branch joint.

3. When the outdoor unit is on the top position and the difference of level is over 20m, it is recommended that set an oil return bend every 10m in the gas pipe of the main pipe, the specification of the oil return bend refers to the figure on the right.

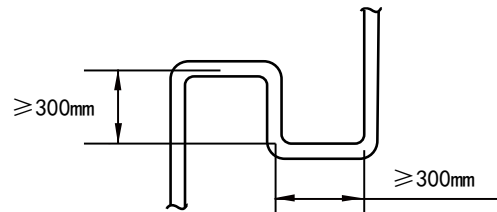

4. When the outdoor unit is on the low position, $H \geq 40m$, the liquid pipe of the main pipe need to increase one size.

5. The allowable length from the first branch joint to the farthest indoor unit should be equal to or shorter than 40m. But the allowable length can extended to 90m, if the selection principle can meets all the following conditions.

Condition	Example
1. It is needed to increase all the pipe diameters of the main distribution pipe which between the first and the last branch joint assembly. (Please change the pipe diameter at field) If the pipe diameter of the main slave pipe is the same as the main pipe, then it is not needed to be increased.	"N10": $L5+L8+L9+j \leq 90m$ L2,L3,L4,L5,L6,L7,L8,L9 Need to increase the pipe diameter of the distribution pipe Increasing size as the following: $\phi 9.5 \rightarrow \phi 12.7$ $\phi 12.7 \rightarrow \phi 15.9$ $\phi 15.9 \rightarrow \phi 19.1$ $\phi 19.1 \rightarrow \phi 22.2$ $\phi 22.2 \rightarrow \phi 25.4$ $\phi 25.4 \rightarrow \phi 28.6$ $\phi 28.6 \rightarrow \phi 31.8$ $\phi 31.8 \rightarrow \phi 38.1$ $\phi 38.1 \rightarrow \phi 41.3$ $\phi 41.3 \rightarrow \phi 44.5$ $\phi 44.5 \rightarrow \phi 54.0$
2. When counting the total extended length, the actual length of above distribution pipes must be doubled. (Expect the main pipe and the distribution pipes which no need to be increased.) $L1+(L2+L3+L4+L5+L6+L7+L8+L9) \times 2+a+b+c+d+e+f+g+h+i+j \leq 1000m$	Refer to Figure.4-1
3. The length from the indoor unit to the nearest branch joint assembly $\leq 40m$ $a,b,c,\dots,j \leq 40m$ (Pipe diameter requirements, please refers to table.4-3)	Refer to Figure.4-1
4. The distance difference between [the outdoor unit to the farthest indoor unit] and [the outdoor unit to the nearest indoor unit] is $\leq 40m$. The farthest indoor unit "N10" The nearest indoor unit "N1" $(L1+L5+L8+L9+j)-(L1+L2+L3+a) \leq 40m$	Refer to Figure.4-1

1.1.2 Select the refrigerant piping

Fig 4-2

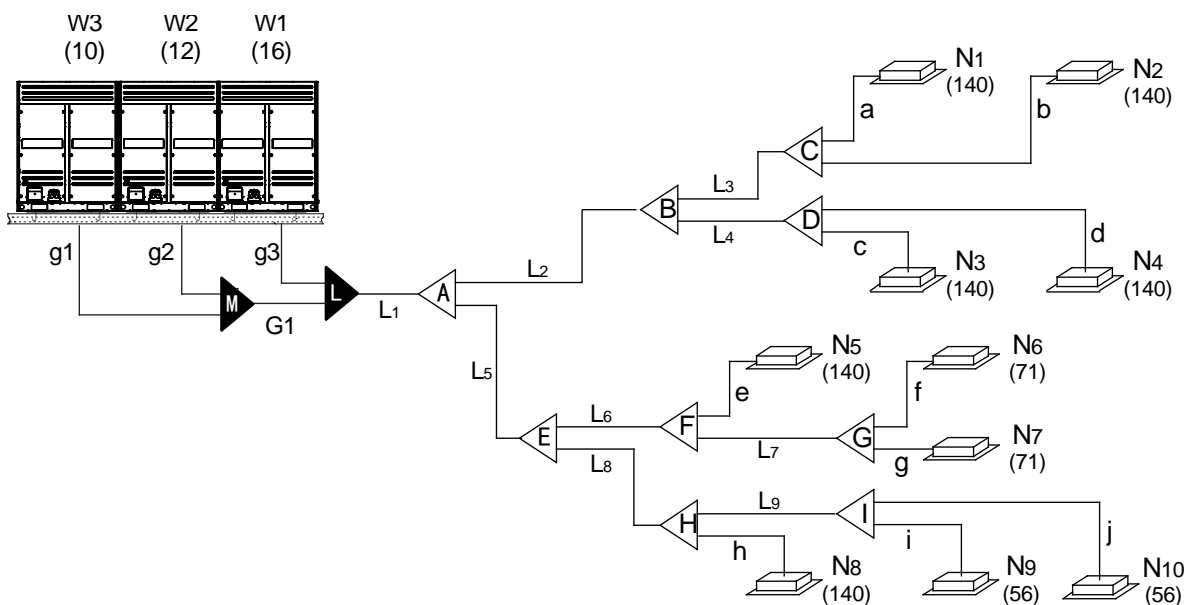

Note: In the above drawing, the capacity unit of indoor side is (x100W), and the outdoor side is HP.

Table 4-2

The Pipe Type	The Detailed Pipe Place	Code
Outdoor unit pipe	The pipe between outdoor unit and outdoor branch, pipe between outdoor branches	g1, g2, g3, G1
Outdoor branch	The outdoor branch assy.	L, M
The main pipe	The pipe between outdoor and the No.1 indoor branch	L1
Indoor main pipe	The pipe between indoor branches	L2~L9
Indoor branch	The indoor branch assy.	A ~ I
Indoor unit pipe	The pipe connecting directly to indoor unit	a ~ j

1.1.2.1 Selection of the indoor unit pipes

E.g. The pipe (a ~ j) in the above drawing.

Please refer to the following table.

Table 4-3

The total capacity of Indoor units(x100W)	When indoor unit pipe length≤10m		When indoor unit pipe length>10m	
	Gas side	Liquid side	Gas side	Liquid side
A≤45	Φ12.7mm	Φ6.35mm	Φ15.9mm	Φ9.53mm
A≥56	Φ15.9mm	Φ9.5mm	Φ19.1mm	Φ12.7mm

1.1.2.2 Selection of the branches and indoor main pipes

E.g. The branches (A ~I) and indoor main pipe (L2~L9) in the above drawing.

Please refer to the following table.

Table 4-4

The capacity of downward indoor units(x100W)	The indoor main pipe dimension (mm)		The branches
	Gas pipe	Liquid pipe	
A<166	Φ15.9	Φ9.5	FQZHN-01D
166≤A<230	Φ19.1	Φ9.5	FQZHN-01D
230≤A<330	Φ22.2	Φ9.5	FQZHN-02D
330≤A<460	Φ28.6	Φ12.7	FQZHN-03D

460≤A<660	Φ28.6	Φ15.9	FQZHN-03D
660≤A<920	Φ31.8	Φ19.1	FQZHN-03D
920≤A<1350	Φ38.1	Φ19.1	FQZHN-04D
1350≤A<1800	Φ41.3	Φ22.2	FQZHN-05D
1800≤A	Φ44.5	Φ25.4	FQZHN-05D

1.1.2.3 Selection of the main pipe (L1)

E.g. The main pipe (L1) in the above drawing

Please refer to the following table:

Table 4-5

The capacity of outdoor units	When total equivalent length<90m			When total equivalent length≥90m		
	Gas side (mm)	Liquid side (mm)	The indoor No.1 distributor	Gas side (mm)	Liquid side (mm)	The indoor No.1 branch
8HP	Φ22.2	Φ9.53	FQZHN-02D	Φ22.2	Φ12.7	FQZHN-02D
10HP	Φ22.2	Φ9.53	FQZHN-02D	Φ25.4	Φ12.7	FQZHN-02D
12~14HP	Φ25.4	Φ12.7	FQZHN-03D	Φ28.6	Φ15.9	FQZHN-03D
16HP	Φ28.6	Φ12.7	FQZHN-03D	Φ31.8	Φ15.9	FQZHN-03D
18~22HP	Φ28.6	Φ15.9	FQZHN-03D	Φ31.8	Φ19.1	FQZHN-03D
24HP	Φ28.6	Φ15.9	FQZHN-03D	Φ31.8	Φ19.1	FQZHN-03D
26~32HP	Φ31.8	Φ19.1	FQZHN-03D	Φ38.1	Φ22.2	FQZHN-04D
34~48HP	Φ38.1	Φ19.1	FQZHN-04D	Φ38.1	Φ22.2	FQZHN-04D
50~64HP	Φ41.3	Φ22.2	FQZHN-05D	Φ44.5	Φ25.4	FQZHN-05D
66~72HP	Φ44.5	Φ25.4	FQZHN-05D	Φ54.0	Φ25.4	FQZHN-06D

Notice: If the total indoor units' capacity is more than the total outdoor units', please select the main pipe diameter according to the bigger one.

E.g. when the total capacity of 16HP+16HP+14HP paralleled outdoor units is 46HP, if the total pipe length is more than 90m, the pipe diameter is Φ38.1 and Φ22.2 according to the above table. While the total indoor units' capacity is 136kW, the pipe diameter is Φ41.3 and Φ22.2 according to the No.1.1.2.2 table. Then, according to the principle of selecting the bigger, the main pipe diameter should be Φ41.3 and Φ22.2.

1.1.2.4 Selection of the branch (L, M) and the outdoor unit pipe (g1, g2, g3, G1)

E.g. The branch (L, M) and outdoor unit pipe (g1, g2, g3, G1) in the above drawing.

When there is only single outdoor unit, please refer to the following table:

Table 4-6

Model	The outdoor unit pipe diameter (mm)	
8HP	Φ25.4	Φ12.7
10HP	Φ25.4	Φ12.7
12HP	Φ31.8	Φ15.9
14HP	Φ31.8	Φ15.9
16HP	Φ31.8	Φ15.9
18HP	Φ31.8	Φ19.1

When the multi outdoor units are paralleled, please refer to the following table:

Table 4-7

Outdoor unit quantity	Drawing example	Outdoor unit connective pipe diameter(mm)	Outdoor branch
-----------------------	-----------------	-------------------------------------------	----------------

2		<p>g1,g2: 8,10HP: $\Phi 25.4/\Phi 12.7$; 12~18HP: $\Phi 31.8/\Phi 15.9$</p>	L: FQZHW-02N1D
3		<p>g1,g2,g3: 8,10HP: $\Phi 25.4\Phi/12.7$; 12~18HP: $\Phi 31.8\Phi/15.9$; G1: $\Phi 38.1/\Phi 19.1$</p>	L+M: FQZHW-03N1D
4		<p>g1,g2,g3,g4: 8,10HP: $\Phi 25.4\Phi/12.7$; 12~18HP: $\Phi 31.8/\Phi 15.9$; G1: $\Phi 38.1/\Phi 19.1$; G2: $\Phi 41.3/\Phi 22.2$</p>	L+M+N: FQZHW-04N1D

Notice: All branches must be purchased from Midea.

1.1.3 Pipe selection example

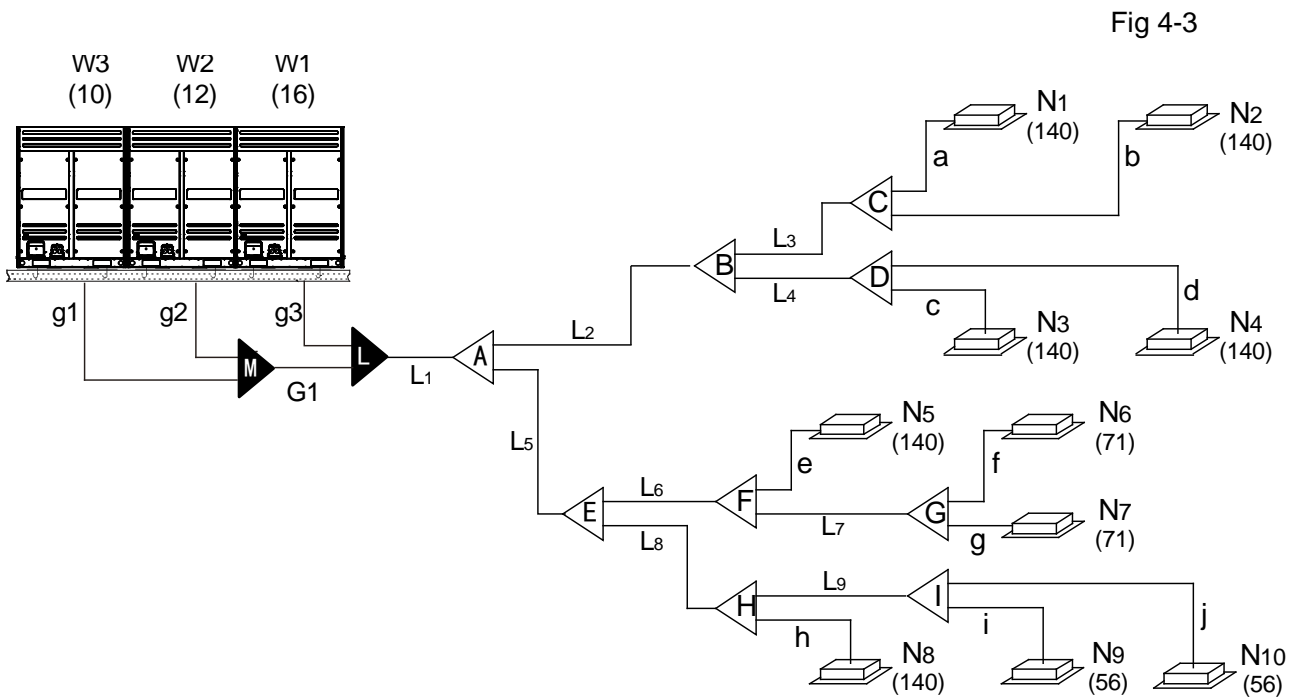

Notice: Suppose total equivalent pipe length beyond 90m.

1.1.3.1 Select each indoor unit pipe(a-j) according to the table 4-3:

Indoor unit pipe	Capacity of indoor units ($\times 100W$)	Range	Indoor unit pipe length	Pipe size Gas/liquid
a	140	$A \geq 56$	Suppose $\leq 10m$	$\Phi 15.9/\Phi 9.5$
b	140	$A \geq 56$	Suppose $\leq 10m$	$\Phi 15.9/\Phi 9.5$
c	140	$A \geq 56$	Suppose $\leq 10m$	$\Phi 15.9/\Phi 9.5$
d	140	$A \geq 56$	Suppose $> 10m$	$\Phi 19.1/\Phi 12.7$
e	140	$A \geq 56$	Suppose $> 10m$	$\Phi 19.1/\Phi 12.7$
f	71	$A \geq 56$	Suppose $\leq 10m$	$\Phi 15.9/\Phi 9.5$
g	71	$A \geq 56$	Suppose $\leq 10m$	$\Phi 15.9/\Phi 9.5$
h	140	$A \geq 56$	Suppose $\leq 10m$	$\Phi 15.9/\Phi 9.5$
i	56	$A \geq 56$	Suppose $\leq 10m$	$\Phi 15.9/\Phi 9.5$
j	56	$A \geq 56$	Suppose $> 10m$	$\Phi 19.1/\Phi 12.7$

1.1.3.2 Select main pipe(L1),indoor main pipe(L2-L9),indoor branch(A-I) according to the table 4-4

Indoor main pipe/ indoor branch	Total capacity of indoor units (×100W)	Range	Pipe dimension (Gas/Liquid)	Branch
L3/C	N1+N2=280	230≤A<330	Φ22.2/Φ9.5	FQZHN-02D
L4/D	N3+ N4=280	230≤A<330	Φ22.2/Φ9.5	FQZHN-02D
L2/B	N1+.....+N4=560	460≤A<660	Φ28.6/Φ15.9	FQZHN-03D
L7/G	N6+N7=142	A<166	Φ15.9/Φ9.5	FQZHN-01D
L6/F	N5+.....+N7=282	230≤A<330	Φ22.2/Φ9.5	FQZHN-02D
L9/I	N9+N10=136	230≤A<330	Φ22.2/Φ9.5	FQZHN-02D
L8/H	N8+.....+N10=276	230≤A<330	Φ22.2/Φ9.5	FQZHN-02D
L5/E	N5+.....+N10=558	460≤A<660	Φ28.6/Φ15.9	FQZHN-03D
L1/A	N1+.....+N10=1118	920≤A<1350	Φ38.1/Φ19.1	FQZHN-04D

1.1.3.3 Select main pipe(L1) and outdoor unit pipe(g1-g3,G1), outdoor branch

Main pipe/outdoor unit pipe/branch	Model	The Max. equivalent pipe length≥ 90m	Range	Branch	Refer to
		Gas Side/ Liquid Side			
g1	10HP	Φ25.4 (Welding)/ Φ12.7(Flaring Nut)	8≤W3≤10HP	/	According to the table 4-7
g2	14HP	Φ31.8(Welding)/15.9(Flaring Nut)	12≤W2≤16HP	/	
g3	16HP	Φ31.8(Welding)/15.9(Flaring Nut)	12≤W1≤16HP	/	
G1	24HP	Φ38.1Welding)/ Φ19.1(Welding)	Two modular combination	/	
L1	38HP	Φ38.1(Welding)/ Φ22.2(Welding)	34-48HP	/	According to the table 4-5
L+M	/	/	Three modular combination	FQZHW-03N1D	According to the table 4-7

1.1.3.4 Compare the total capacity from indoor side and outdoor side, select the main pipe diameter according to the bigger one.

Main pipe L1 in the Fig.4-3, which upstream outdoor units total capacity is 10+12+16=38, base on table.4-5, the gas/liquid pipe diameter areΦ38.1/Φ22.2, total capacity of the downstream indoor unit is 140×6+56×2+71×2= 1094, base on table.4-4, the gas/liquid pipe diameter are Φ38.1/Φ19.1, take the large one for your selection, final confirm the main pipe diameter is: gas/liquid pipe Φ38.1/Φ22.2.

1.1.4 Branch drawing

1.1.4.1 Indoor branch drawing

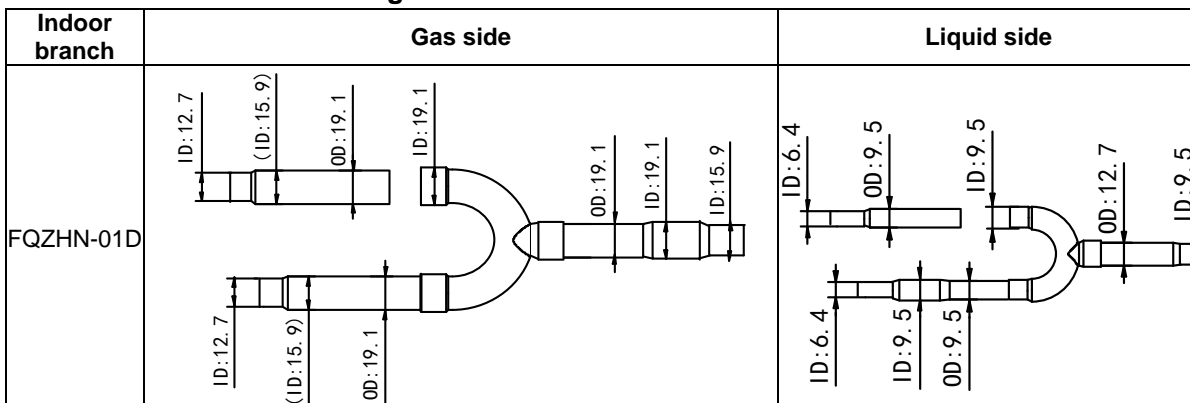

<p>FQZHN-02D</p>		
<p>FQZHN-03D</p>		
<p>FQZHN-04D</p>		
<p>FQZHN-05D</p>		
<p>FQZHN-06D</p>		

1.1.4.2 Outdoor branch drawing

Outdoor branch	FQZHW-02N1D	FQZHW-03N1D	FQZHW-04N1D
Gas side			
Liquid side			
Oil balance pipe	/	<p style="text-align: center;">P</p>	<p style="text-align: center;">P</p> <p style="text-align: right;">(2 pcs)</p>

1.3 Installation Procedure

1.3.1 Importance of the Installation Operation

Effect of installation issues on equipment:

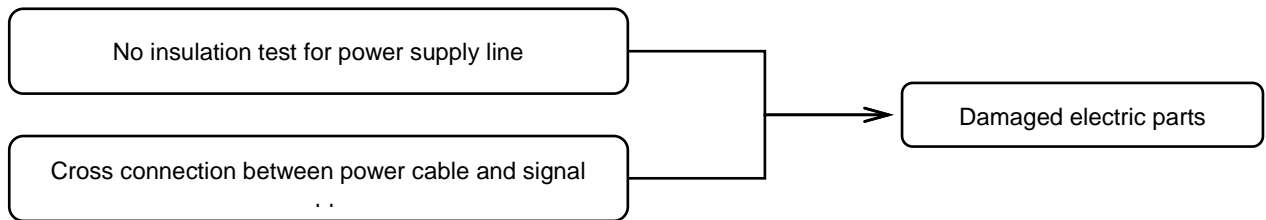
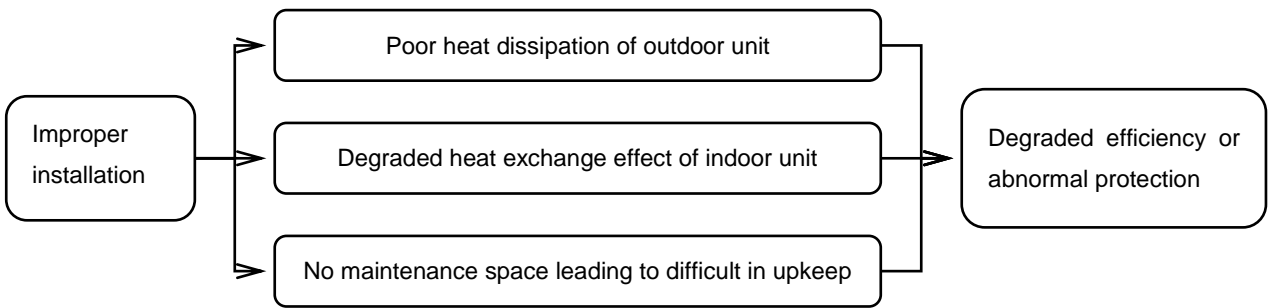
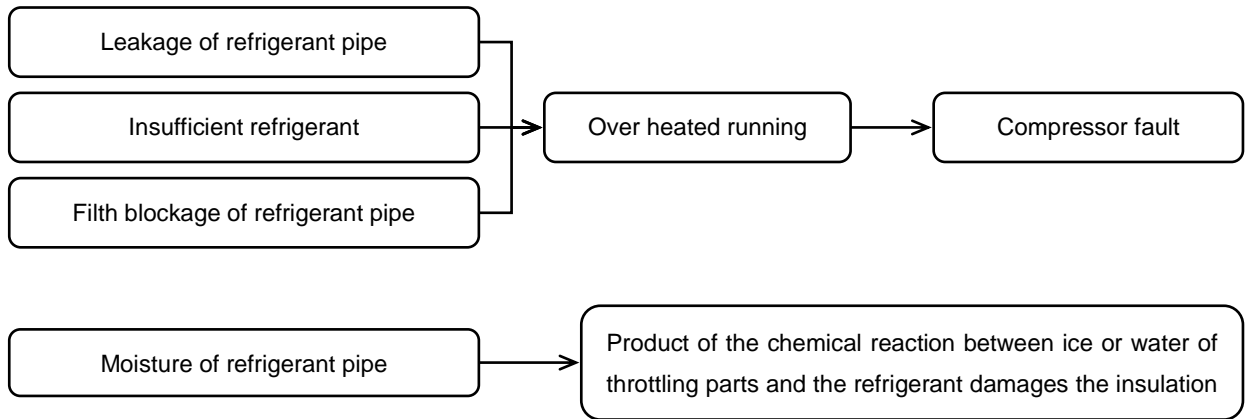

1.3.2 General procedure

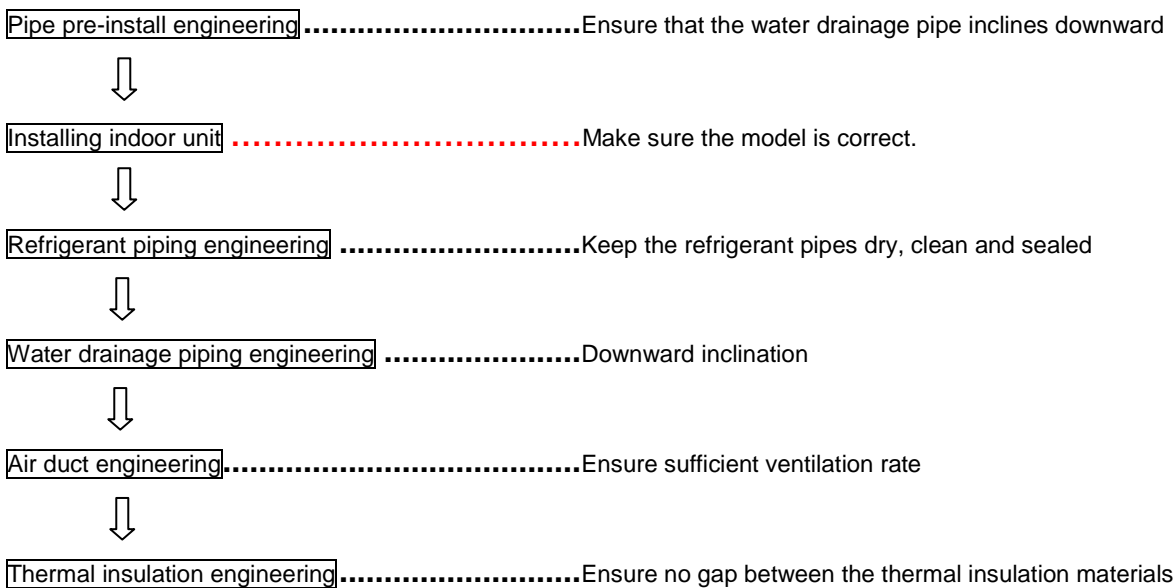

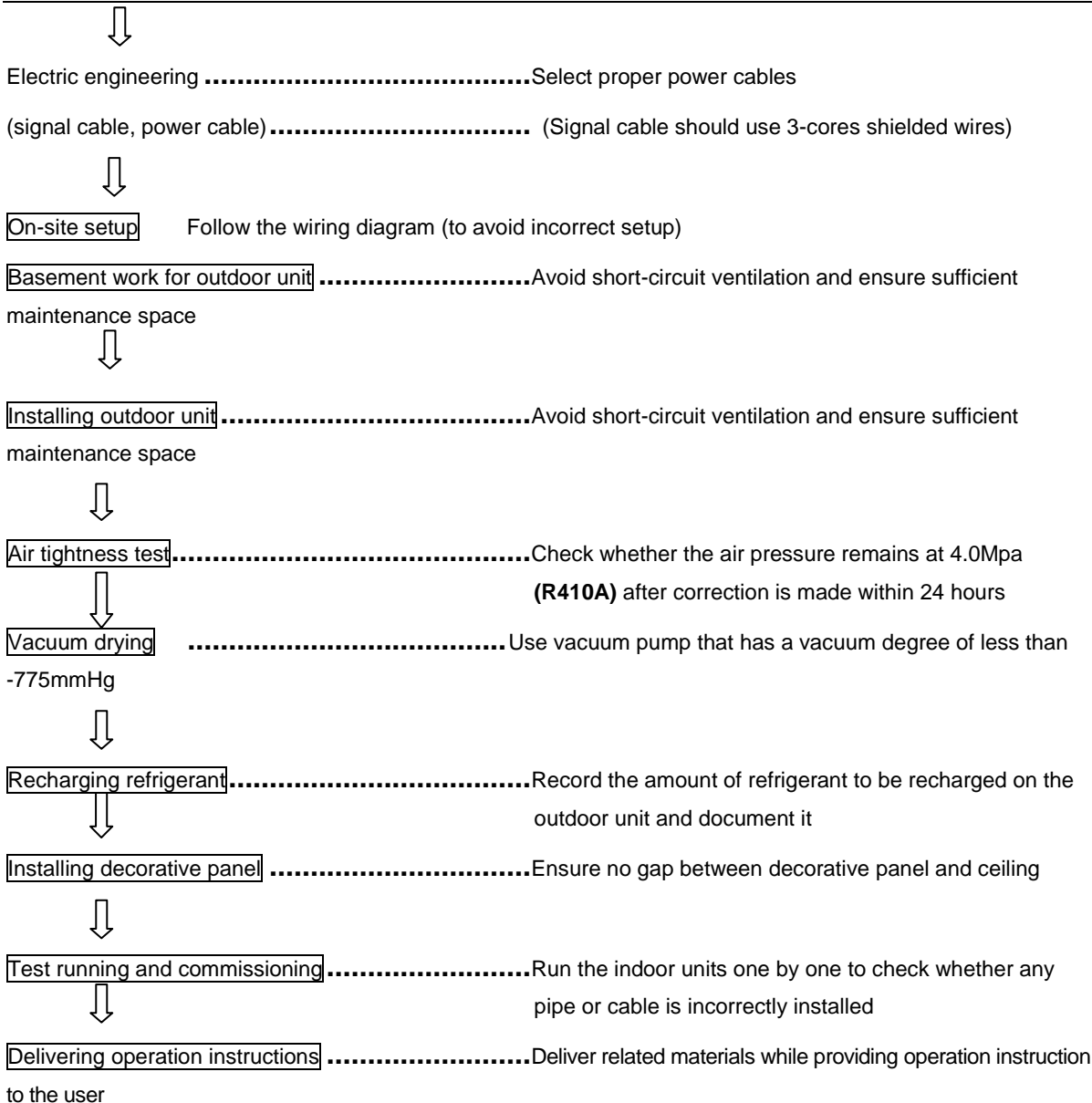

Note: The general procedure for refrigerant machine is subject to change according to the situation

1.3.2 Install indoor unit's procedure

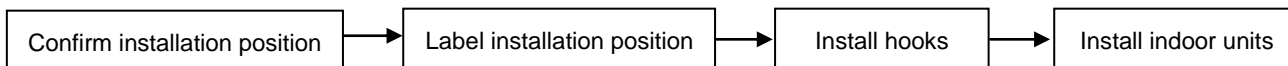

- Note:**
- 1.The hook must strong enough to sustain the weight of indoor unit.
 - 2.Check the models of indoor units before installation.
 - 3.Pay attention to the main devices, such as the pipeline.
 - 4.Hold enough places for maintenance.

1.3.3 Refrigerant pipe procedure

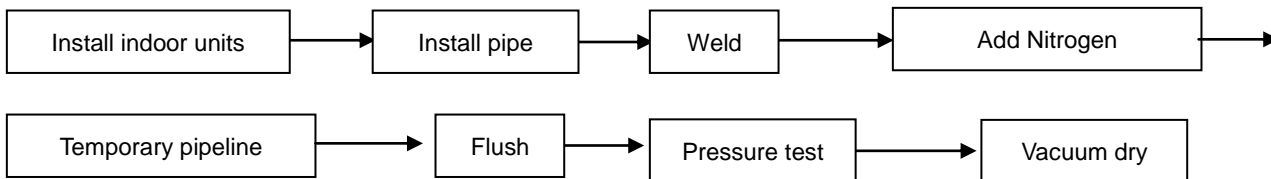

1.3.4 Drainage pipe procedure

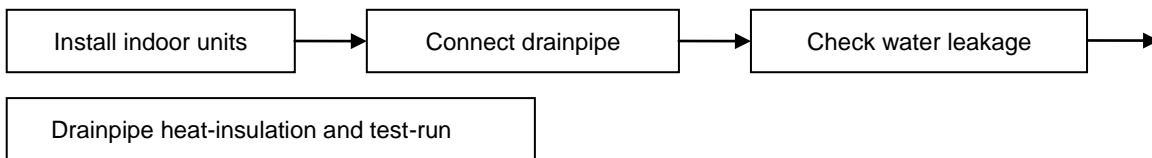

Note: It is no need to insulate the drainpipe if you choose the plastic pipe as drainpipe.

1.3.5 Electric wiring

1.3.5.1 Please select power supply for indoor and outdoor units separately. Both indoor and outdoor units should be grounded well.

1.3.5.2 The power supply should have specified branch circuit with leakage protector and manual switch.

1.3.5.3 Please connect the indoor units and outdoor units in one refrigerant piping system.

1.3.5.4 Power wiring should be done by professional electrician and complied with relevant National Electric Standard.

1.3.5.5 The power supply, leakage protector and manual switch of all the indoor units connecting to the same outdoor unit should be universal. (Please set all the indoor unit power supply of one system into the same circuit.)

1.3.5.6 It is suggested to use 3-core shielded wire as signal wire between indoor and outdoor units, multi-core wire is unavailable. Pay attention to the consistency. When signal wire parallel to the power wire, please keep enough distance (about 300mm at least) to prevent interference.

1.3.5.7 The power wire and signal wire can't be enlaced together.

1.3.6 Lay the indoor pipeline

Note: Collocate the air-outlet reasonably to prevent airflow short-circuit. Check the static pressure whether in the allowable range. The air filters should be easy to unpick and wash. Do pressure test on pipeline.

1.3.7 Heat-insulation procedure

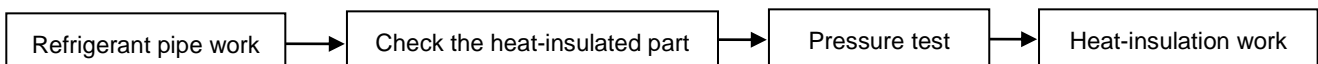

Note: For welding part, flare part and branch pipe, heat-insulation work must be done after finished the pressure test.

1.3.8 Install outdoor unit

Note: 1. Gutter must be set around the foundation to drain the condensation water.

2. When installing outdoor units at the roof, please check the strength of the roof and pay attention not to destroy the waterproof of the roof.

1.3.9 Recharge refrigerant procedure

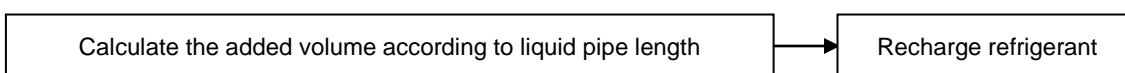

Note: Please calculate the additional amount of refrigerant according to the formula that we supply to you, and the calculation result must be correct.

1.3.10 Main points of test running and Commissioning

Please check the following issues before turning on the power:

1.3.10.1 Vacuum dry: Make sure the vacuum degree accord with our requirement about 10^{-5} .

1.3.10.2 Wiring: Includes the power wiring and communication wiring; Recheck the connection according to our corresponding wire diagrams. Especially, please remember our communication

wire is polar; it means you must connect the communication wire correspondingly to the terminal block.

1.3.10.3 Additional charge of refrigerant: Recheck the calculation formula and recalculate the total recharge volume according to our supplied formula.

1.3.10.4 Open the stop-valve of gas and liquid pipe with Allen key; Check leakage of stop-valve with soap water. Please confirm whether the outdoor unit has been connected to the power for 12h before start test running.

Test running: Turn on all of the indoor units with cooling mode and set the temperature in 17degree with high fan speed first, after the system operated, test following operation parameters of the system, including indoor units and outdoor units parameters.

1.4 Installation Preparation

1.4.1 Installation tools and instruments

All the necessary tools should be available, and their models and specifications should meet the installation and technical requirements. The instruments and meters should be tested or verified, and their scales and accuracy should meet the requirements. The common tools for installing refrigerant machine are listed below.

No.	Name	Specification/Model	No.	Name	Specification/Model
1	Pipe cutter		15	Electronic scale	
2	Steel saw		16	Stop	
3	Pipe bender	Spring, mechanic	17	Thermometer	
4	Pipe expander	Depend on the pipe diameter specification	18	Meter rule	
5	Flaring tool	Depend on the pipe diameter specification	19	Screw driver	"-", "+"
6	Brazing welder	Depend on the nozzle size		Adjustable spanner	
7	Scraper		21	Resistance tester	
8	File/Rasp		22	Electro probe	
9	Injection tube		23	Multimeter	
10	Double-ended pressure gauge	4.0MPa	24	Pressure reducing valve	
11	Pressure gauge	1.5MPa, 4.0MPa	25	Wire pliers	
12	Vacuum gauge	-756mmHg	26	Clamping pliers	
13	Vacuum pump	At least 4 liters/second	27	Hexagon ring spanner	
14	Horizontal rule		28	Torque wrench	

In addition, tools such as electric welder, cutter, A-shape ladder, electric drill, folding machine, forming machine, nitrogen cylinder are also generally used during the installation.

1.4.2 Audit of construction drawings

Before the engineering installation, read carefully the related drawings to understand the design intention, audit the drawings, and then work out a detailed engineering organization plan.

1. Make sure that the pipe diameters and branch pipe models meet the technical specifications.
2. Ratio of slope, drainage mode and thermal insulation of condensate water.
3. Making of air duct and air opening, and air ventilation organization.
4. Configuration specifications, model and control mode of power cables.
5. Making, total length and control mode of control cable.

The engineering construction staff should follow the construction drawing strictly during the construction. If any change is required, such change should be approved by the design

department and be documented.

1.4.3 Construction organization plan

Construction organization plan serves as the comprehensive technical and economic documents that guide the construction preparation and scientific construction organization. A reasonable construction organization plan and careful implementation of it are essential to ensure smooth construction, shorten construction period, ensure construction quality, and improve economic results.

The construction plan should be concise and focuses on key procedures, construction method, and time coordination, space disposal of the construction around the features of the engineering, thus to ensure smooth construction operation.

1.4.4 Training of installation team

Establish sound training mechanisms. Service engineers are required to train installation team managers, work supervisors to train workers, and managers to train workers of special type. Establish a management mechanism in which pre-working training, before-shift disclosure and after-shift implementation are available.

1.4.5 Coordination with other sectors

Ensure smooth coordination and meticulous organization between these sectors: air conditioning, civil work, electricity, water supply and drainage, fire protection, decoration, intelligence, etc. Try best to lay pipes of the air conditioning system along the bottom of the beam. If pipes meet together at the same height, follow these principles:

1. Ensure that gravity pipes take precedence over water drainage pipes, air ducts and pressure pipes.
2. Ensure that large pipes take precedence over air ducts and small pipes.

1.4.6 Pipe pre-install engineering

1.4.6.1 Operation procedure

Raise requirements to the civil work sector and coordinate → Determine the position, size and quantity of the machines, and conduct pre-installing → Check the pre-installing results

1.4.6.2 Pipeline route

1. The pipe for condensate water should have a downward slope (the slope should be at least 1/100).
2. The diameter of the through hole for the refrigerant pipe should take the thickness of the thermal insulation material into consideration (it is recommended to lay the gas pipe and liquid pipe in two separate columns).
3. Note that sometimes through hole is not allowed because of the structure of the beam.

eg. Strengthen the transfixion hole

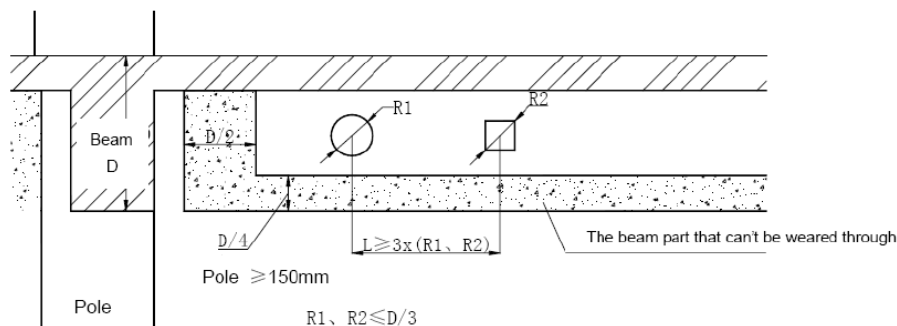

Highlights:

- 1) When selecting the parts to be pre-installed, ensure that the weight of the accessories is also calculated.

2) In a situation where metal parts to be pre-installed is not allowed, use expansion bolts while ensuring sufficient load-bearing capacity.

Caution: The above figure is for reference only. It is not recommended to dig holes on either the beam or the shear wall. If such operation is indeed needed, please consult the property owner (or manager) and the civil work sector, and get written approval from the competent authority.

1.4.7 Warning

(1) Be sure only trained and qualified service personnel to install, repair or service the equipment. Improper installation, repair, and maintenance may result in electric shocks, short-circuit, leaks, fire or other damage to the equipment.

(2) Install according to this installation instructions strictly.

If installation is defective, it will cause water leakage, electrical shock fire.

(3) When installing the unit in a small room, take measures against to keep refrigerant concentration from exceeding allowable safety limits in the event of refrigerant leakage.

Contact the place of purchase for more information. Excessive refrigerant in a closed ambient can lead to oxygen deficiency.

(4) Use the attached accessories parts and specified parts for installation. otherwise, it will cause the set to fall, water leakage, electrical shock fire.

(5) Install at a strong and firm location which is able to withstand the set' s weight.

If the strength is not enough or installation is not properly done, the set will drop to cause injury.

(6) The appliance must be installed 2.5m above floor.

(7) The appliance shall not be installed in the laundry.

(8) Before obtaining access to terminals, all supply circuits must be disconnected.

(9) The appliance must be positioned so that the plug is accessible.

(10) The enclosure of the appliance shall be marked by word, or by symbols, with the direction of the fluid flow.

(11) For electrical work, follow the local national wiring standard, regulation and installation instruction. An independent circuit and single outlet must be used.

If electrical circuit capacity is not enough or defect in electrical work, it will cause electrical shock fire.

(12) Use the specified cable and connect tightly and clamp the cable so that no external force will be acted on the terminal.

If connection or fixing is not perfect, it will cause heat-up or fire at the connection.

(13) Wiring routing must be properly arranged so that control board cover is fixed properly.

If control board cover is not fixed perfectly, it will cause heat-up at connection point of terminal, fire or electrical shock.

(14) If the supply cord is damaged, it must be replaced by the manufacture or its service agent or similarly qualified person in order to avoid a hazard.

(15) An all-pole disconnection switch having a contact separation of at least 3mm in poles should be connected in fixed wiring.

(16) When carrying out piping connection, take care not to let air substances go into refrigeration cycle.

Otherwise, it will cause lower capacity, abnormal high pressure in the refrigeration cycle, explosion and injury.

(17) Do not modify the length of the power supply cord or use of extension cord, and do not share the single outlet with other electrical appliances.

Otherwise, it will cause fire or electrical shock.

(18) Carry out the specified installation work after taking into account strong winds, typhoons or earthquakes.

Improper installation work may result in the equipment falling and causing accidents.

Remark: Failure to observe a warning may result in death.

1.4.8 Caution

(1) Ground the air conditioner.

Do not connect the ground wire to gas or water pipes, lightning rod or a telephone ground wire. Incomplete grounding may result in electric shocks.

(2) Be sure to install an earth leakage breaker.

Failure to install an earth leakage breaker may result in electric shocks.

(3) Connect the outdoor unit wires, and then connect the indoor unit wires.

You are not allowed to connect the air conditioner with the power source until wiring and piping the air conditioner is done.

(4) While following the instructions in this installation manual, install drain piping in order to ensure proper drainage and insulate piping in order to prevent condensation.

Improper drain piping may result in water leakage and property damage.

(5) Install the indoor and outdoor units, power supply wiring and connecting wires at least 1 meter away from televisions or radios in order to prevent image interference or noise.

Depending on the radio waves, a distance of 1 meter may not be sufficient enough to eliminate the noise.

(6) The appliance is not intended for use by young children or infirm persons without supervision. Young children should be supervised to ensure that they do not play with the appliance.

(7) Don't install the air conditioner in the following locations:

There is petrolatum existing.

There is salty air surrounding (near the coast).

There is caustic gas (the sulfide, for example) existing in the air (near a hot spring).

The Volt vibrates violently (in the factories).

In buses or cabinets.

In kitchen where it is full of oil gas.

There is strong electromagnetic wave existing.

There are inflammable materials or gas.

There is acid or alkaline liquid evaporating.

Other special conditions.

(8) The insulation of the metal parts of the building and the air conditioner should comply with the regulation of National Electric Standard.

Remark: Failure to observe a caution may result in injury or damage to the equipment.

2. Units Installation

2.1 Installation of Indoor Unit

2.1.1 Installation procedure

Determine the installation position → Scribing and locating → Installing suspension road → Installing the indoor unit

2.1.2 Cautions for installation and check

- 1) Drawing check: Confirm the specification, model and installation direction of the set.
- 2) Height: Ensure that it closely fits the ceiling.
- 3) Suspension strength: The suspension road shall be strong enough to bear the weight twice of the indoor unit to ensure that no abnormal vibration or noise is generated when the set is running.
- 4) When installing the indoor unit, ensure that sufficient space is available for installing condensate water pipe.
- 5) Horizontal degree: It shall be kept within $\pm 1^\circ$.

Purpose: Ensure smooth drainage of condensate water. Also ensure stability of the machine body to induce the risks caused by vibration and noise.

Hidden trouble of incorrect operation: a. Water leakage; b. Abnormal vibration and noise

- 6) Ensure sufficient maintenance & upkeep is available (keep a large enough maintenance hole, typically 400x400mm).

- 7) Avoid short-circuit ventilation.

Purpose: Ensure sufficient heat exchange of indoor unit and good air conditioning effect.

Risk of incorrect operation: Poor air conditioning effect; abnormal protection of the set.

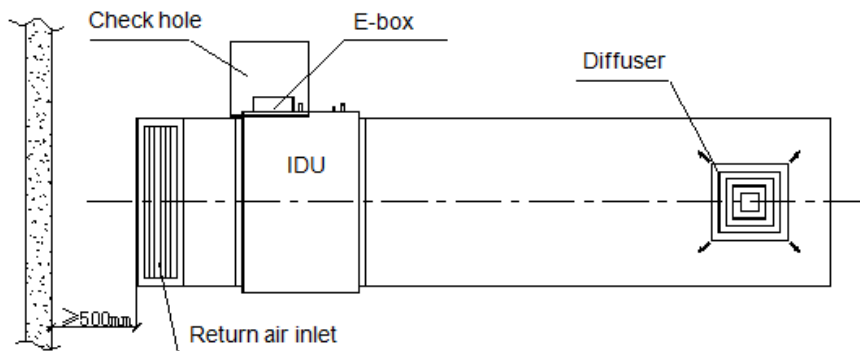

2.2. Installation of Outdoor Unit

2.2.1 Acceptance and unpacking

1. After the machine arrives, check whether it is damaged during the shipment. If the surface or inner side of the machine is damaged, submit a written report to the shipping company.
2. Check whether the model, specification and quantity of the equipment conform to the contract.
3. After removing the outer package, please keep the operation instructions well and count the accessories.

2.2.2 Hoisting outdoor unit

Do not remove any package before the hoisting. Use two ropes to hoist the machine, keep the machine in balance, and then raise it safely and steadily. In case of no package or if the package is damaged, use plates or packing material to protect it.

When conveying and hoisting the outdoor unit, keep it upright, ensure that the slope does not exceed 30° , and keep safety in mind.

2.2.3 Selecting installation position

1. Ensure that the outdoor unit is installed in a dry, well-ventilated place.
2. Ensure that the noise and exhaust ventilation of the outdoor unit do not affect the neighbors of the property owner or the surrounding ventilation.
3. Ensure that the outdoor unit is installed in a well-ventilated place that is possibly closest to the indoor unit.
4. Ensure that the outdoor unit is installed in a cool place without direct sunshine exposure or direct radiation of a high-temperature heat source.
5. Do not install the outdoor unit in a dirty or severely polluted place, so as to avoid blockage of the heat exchanger in the outdoor unit.
6. Do not install the outdoor unit in a place with oil pollution, salt or high content of harmful gases such as sulfurous gas.

2.2.4 Base for outdoor unit

1. A solid, correct base can:
 - 1) Avoid the outdoor unit from sinking.
 - 2) Avoid the abnormal noise generated due to base.
2. Base types
 - 1) Steel structure base
 - 2) Concrete base (see the figure below for the general making method)

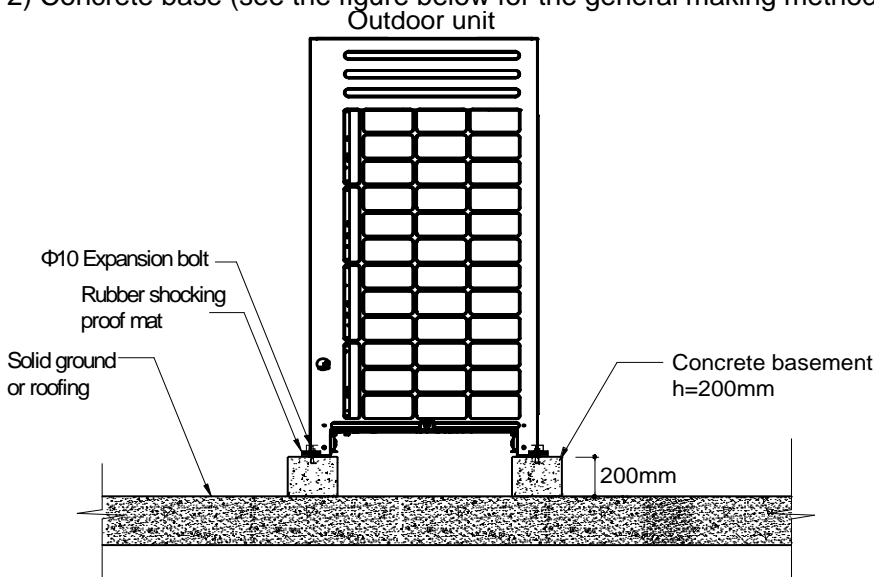

Remark:

The key points to make basement:

- 1) The master unit's basement must be made on the solid concrete ground. Refer to the structure diagram to make concrete basement in detail, or make after field measurements.
- 2) In order to ensure every point can contact equality, the basement should be on completely level.
- 3) If the basement is placed on the roofing, the detritus layer isn't needed, but the concrete surface must be flat. The standard concrete mixture ratio is cement 1/ sand 2/ carpolite 4, and adds Φ10 strengthen reinforcing steel bar, the surface of the cement and sand plasm must be flat, border of the basement must be chamfer angle.
- 4) In order to drain off the seeper around the equipment, a discharge ditch must be setup around the basement.
- 5) Please check the affordability of the roofing to ensure the load capacity.

2.2.5 Installation highlights for outdoor unit

1. Install vibration isolator or isolating pad between the set and the base by the design specification.
2. Ensure close between the outdoor unit and the base, or significant vibration and noise may occur.
3. Ensure that outdoor unit is well grounded.
4. Before commissioning, do not turn on the valves of the gas pipe and liquid pipe of the outdoor unit.
5. Ensure sufficient maintenance space is available at the installation site.

2.2.6 Installation space for outdoor unit.

1) One row:

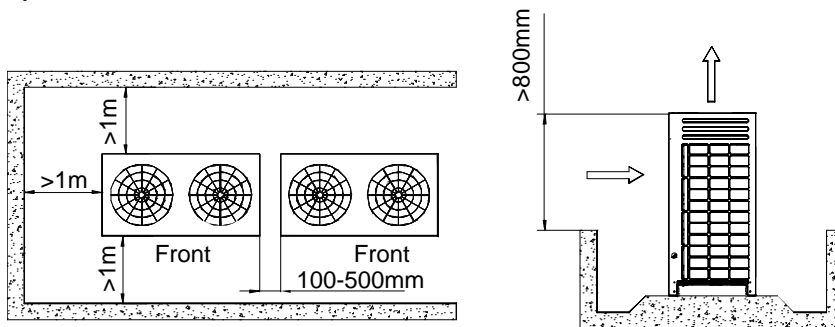

2) Two rows

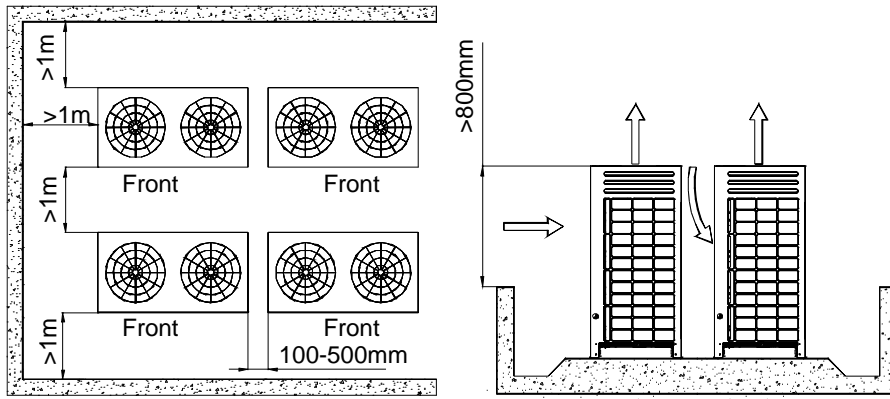

3) More than two rows

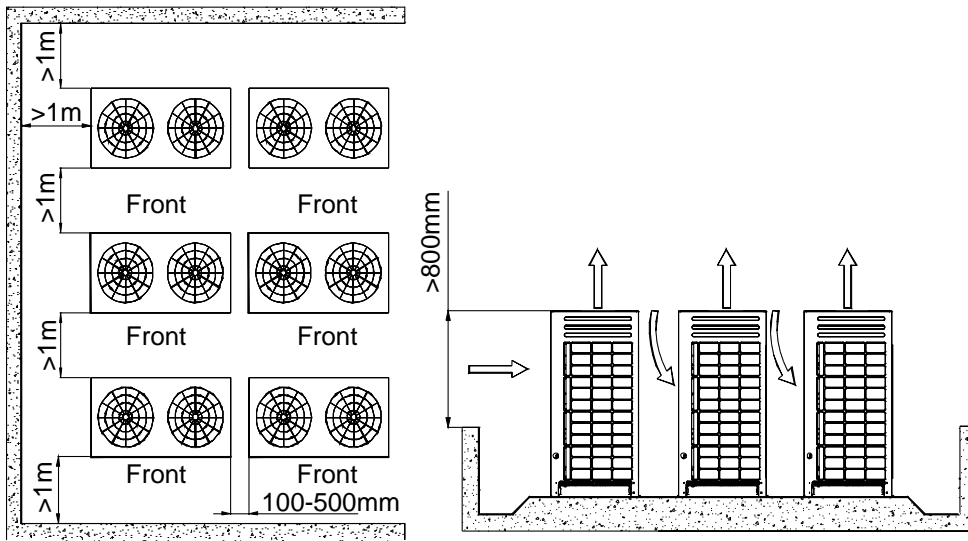

4) When the outdoor unit is lower than the surrounding obstacle,

Refer to the layout used when the outdoor unit is higher than the surrounding obstacle. However, to avoid cross connection of the outdoor hot air from affecting the heat exchange effect, please add an air director onto the exhaust hood of the outdoor unit to facilitate heat dissipation. See the figure below. The height of the air director is HD (namely H-h). Please make the air director onsite.

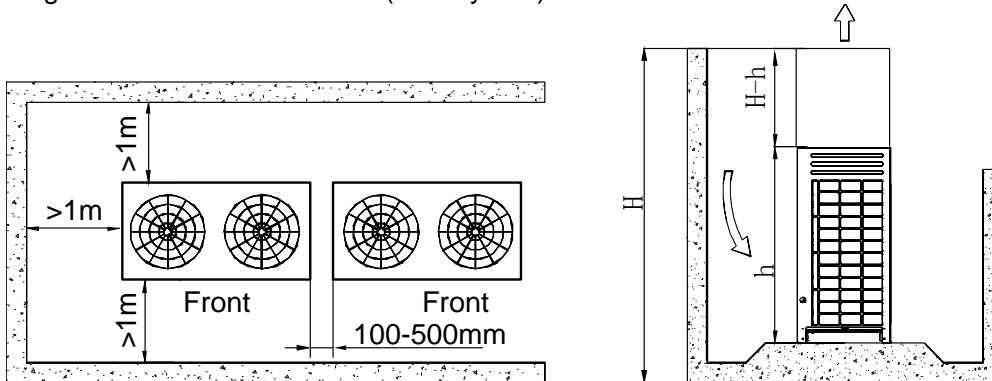

5) For limited space installation

The dimensions should meet the request according to the marks, otherwise, a mechanic exhaust device must be added.

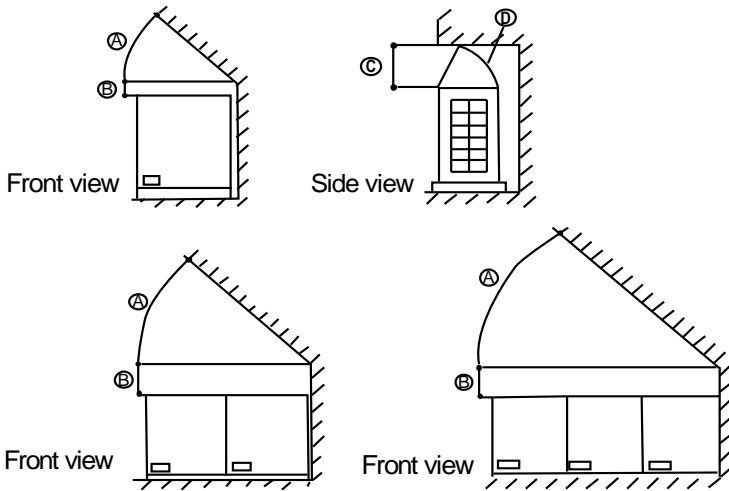

- Ⓐ >45°
- Ⓑ >300mm
- Ⓒ >1000mm
- Ⓓ Airflow deflector

6) Set the snow-proof facility

In snowy areas, facilities should be installed to prevent snow. (See the figure below) (defective facilities may cause malfunction.) Please lift the bracket higher and install snow shed at the air inlet and air outlet.

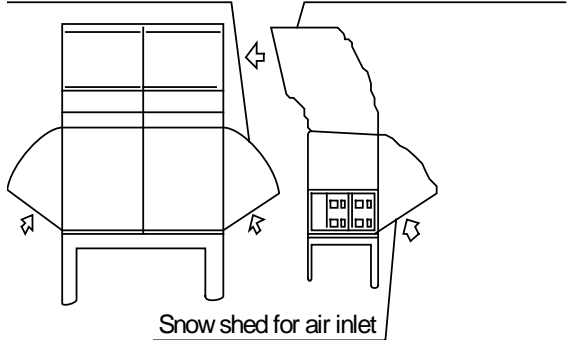

2.2.7 Mount the air deflector

When installing, takes off the mesh firstly, and then conduct in according of the following two schedules.

2.2.7.1 Installation of 8HP,10HP.

Schedule 1:

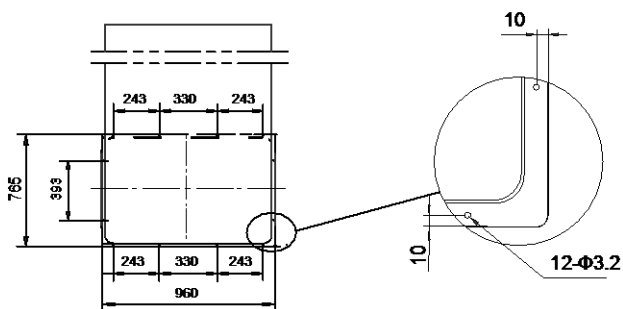
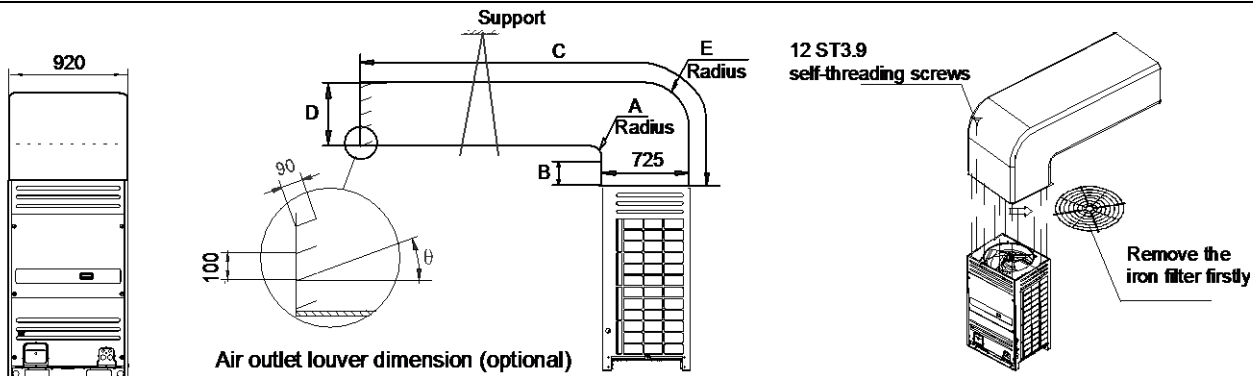

Unit: mm

A	$A \geq 300$
B	$B \geq 250$
C	$C \leq 3000$
D	$725 \leq D \leq 760$
E	$E = A + 725$
θ	$\theta \leq 15^\circ$

Schedule 2:

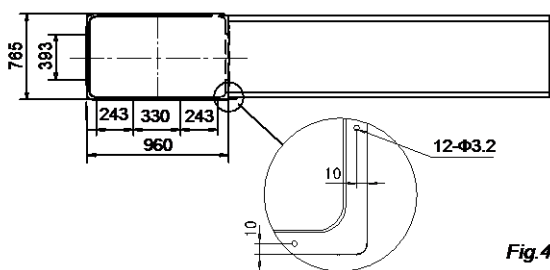
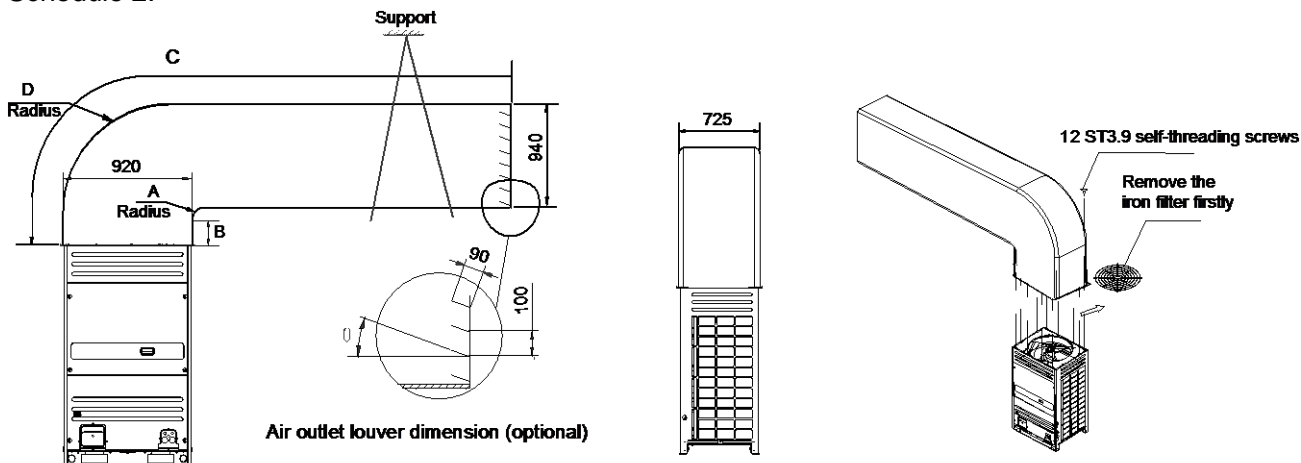

Unit: mm

A	$A \geq 300$
B	$B \geq 250$
C	$C \leq 3000$
D	$D = A + 920$
θ	$\theta \leq 15^\circ$

Fig.4-23

2.2.7.2 Installation of 12HP,14HP,16HP, 18HP
Schedule 1:

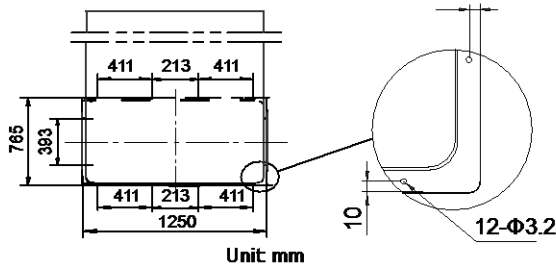
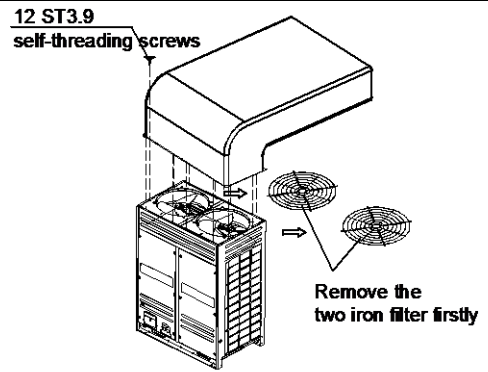
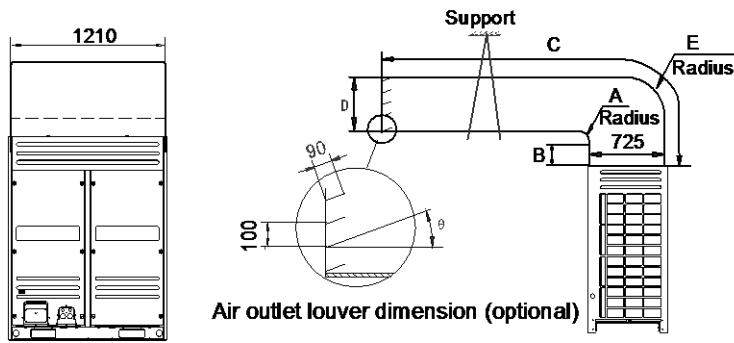

Unit: mm

A	$A \geq 300$
B	$B \geq 250$
C	$C \leq 3000$
D	$725 \leq D \leq 760$
E	$E = A + 725$
θ	$\theta \leq 15^\circ$

Schedule 2:

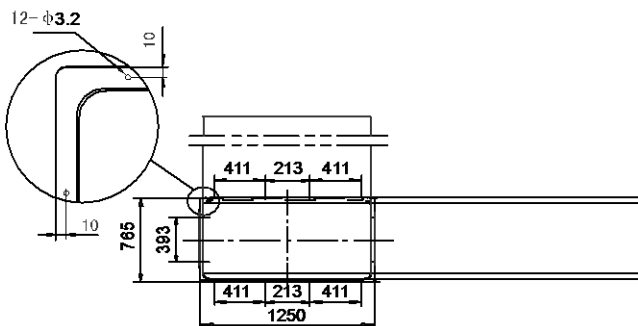
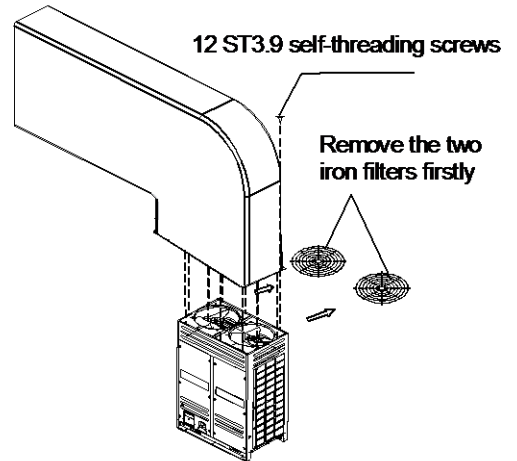
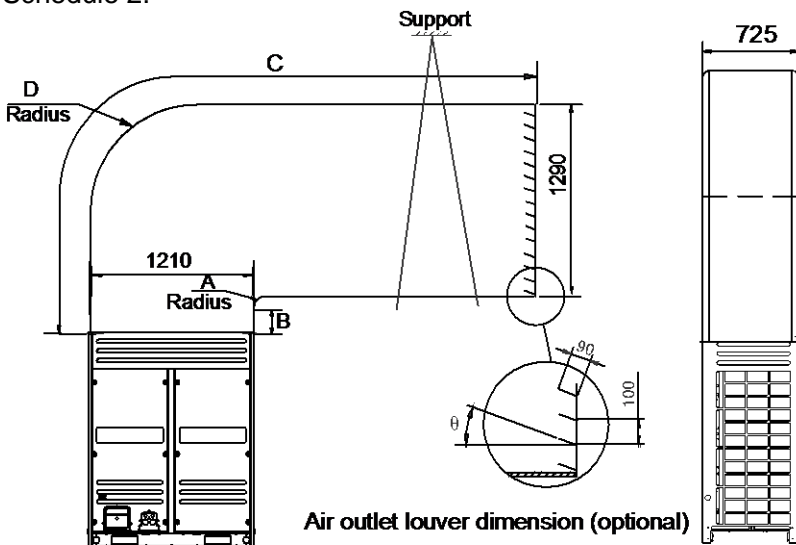

Unit: mm

A	$A \geq 300$
B	$B \geq 250$
C	$C \leq 3000$
D	$D = A + 1210$
θ	$\theta \leq 15^\circ$

Note: Before install the air deflector, please ensuring the mesh enclosure has been took off; otherwise the air supply efficiency would be block down.
 Once mounting the shutter to the unit, air volume, cooling (heating) capacity and efficiency would be block down, this affection enhance along with the angle of the shutter. Thus, we are not recommend you to mount the shutter, if necessary in use, please adjust the angle of shutter no larger than 15°. Only one bending site is allowed in the air duct, otherwise, device may be disoperation.

2.2.8 Arrangement of outdoor units

If more than two outdoor units are combined in the system, these outdoor units shall be arranged according to the descending order of their cooling capacity, and the outdoor unit with the highest cooling capacity shall be placed at the first branch pipe. In addition, the outdoor unit with the highest cooling capacity shall be set to master unit, while others shall be set to slave units.

The following takes a system with outdoor units of 40HP (10HP+14HP+16HP) as an example:

1) Place the outdoor unit of 16HP beside the first branch pipe (see the figure below)

2) Place the outdoor units in the descending order of their cooling capacity, namely, 16HP, 14HP and 10HP.

3) Set the outdoor unit of 16HP to master unit, and the outdoor units of 14HP and 10HP to slave unit.

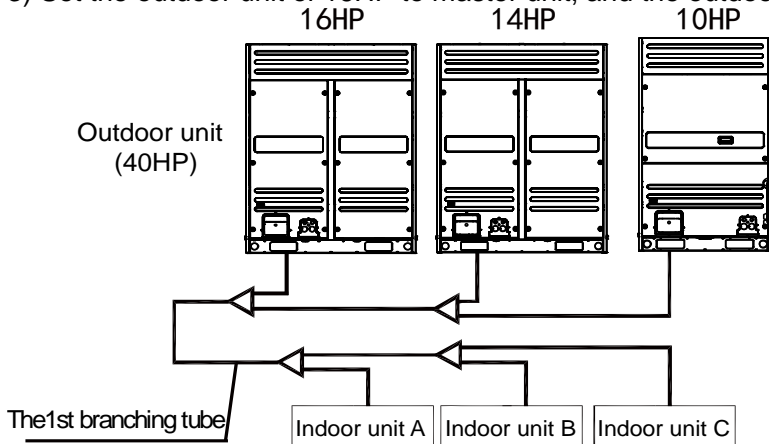

Remark: All the outdoor units should be installed on the location of same level, or it may cause imbalance of refrigerant distributing and lead the fault of the compressors.

Although the V4+ K series outdoor units can **balance the load automatically** due to the master free cycle duty operation, but it is still recommended to install the biggest unit close to the first branch and set as master also.

3. Refrigerant Pipe Engineering

3.1 Refrigerant Pipe Processing

3.1.1 Basic requirements

3.1.1.1 Operation procedure

Determine the route and size of the pipeline according to the construction drawing → Make and installing

bracket, hanger and support → Make and arrange pipe accessories → Recharge nitrogen gas for protection

→ Brazing welding → Pipe flushing → air tightness test → Thermal insulation → Vacuum drying

3.1.1.2 Three principles for refrigerant piping

Item	Reasons	Countermeasure
Dry	The rain comes into/ Engineering water comes into/ Produced condensate water in the pipe	The process of tubing must be criterion → Blow cleanly → Vacuum
Cleanness	There are oxide produced by welding/Outside dust/ Sundries comes into	Charge nitrogen gas to prevent when welding → Blow cleanly Attention the cleanness during the piping process
Air tightness	Imprecision weld/ unqualified airproof to bell-mouth/Leakage of the fringe	Use the suited welding rod to weld Comply to the welding operation criteria Comply to bell-mouth connecting operation criteria Comply to the interface operation criteria → Air tightness test

Caution: Removing oil for copper pipe of a system that uses R410A

For the system that uses R410A, oil-free copper pipes should be selected (they can also be customized). If ordinary (oily) copper pipes are used, it must be cleaned with gauze that is dipped into tetrachloroethylene solution.

Purpose of cleansing copper pipe: Remove the lube (industrial oil used during the processing of the copper pipe) attached to the inner wall of the copper pipe. The ingredients of such lube are different from those of the lube used by the R410A refrigerant, and they will produce deposit through reaction, which may cause complicated system fault.

Special Note: Never use CCl4 for pipe cleansing and flushing, or the system will be seriously damaged.

3.1.1.3. Support for refrigerant pipe

1. Fixing horizontal pipe

When the air conditioner is running, the refrigerant pipe will deform (for example, shrunk/expanded or inclined downward). To avoid pipe damage, use hanger or support to support it (see the table below for the criteria).

Pipe Diameter (mm)	Less than Φ20	Φ20-40	Larger than Φ40
Interval between support points (m)	1	1.5	2

In general, gas pipe and liquid pipe should be suspended in parallel, and the interval between support points should be selected according to the diameter of the air pipe. Since the temperature of the flowing refrigerant will change as the operation and working condition change, which will result in hot expansion and cold shrinkage of the refrigerant pipe, so the pipe with thermal insulation should not be clamped tightly, otherwise the copper pipe may get broken due to stress concentration.

2. Fixing vertical pipe

Fix the pipe along the wall according to the pipeline route. Round log should be used at the pipe clip to replace thermal insulation material, “U”-shape pipe should be fixed outside the round log, and the round log should be provided with anticorrosion treatment.

Pipe Diameter (mm)	Less than Φ20	Φ20-40	Larger than Φ40
Interval between support points (m)	1.5	2.0	2.5

3. Local fixing

To avoid stress concentration due to expansion and shrinkage of the pipe, it is usually required to conduct local fixing beside the wall through-holes of the branch pipe and end pipe.

3.1.1.4 Requirements for installing branch pipe subassembly

When laying the branch pipe subassembly, pay attention to the following:

- 1) Do not replace branch pipe with tee pipe.
- 2) Follow the construction drawing and installation instructions to confirm the models of branch pipe subassembly as well as the diameters of main pipe and branch pipe.
- 3) Neither sharp bend (an angle of 90°) nor connection to other branch pipe subassembly is allowed at places within 500mm away from the branch pipe subassembly.
- 4) Try best to install the branch pipe subassembly at a place that facilitates welding (if doing so is impossible, it is recommended to prefabricate the subassembly).
- 5) Install vertical or horizontal branch joint, and ensure that the horizontal angle is within 10°. Refer to the right side picture:

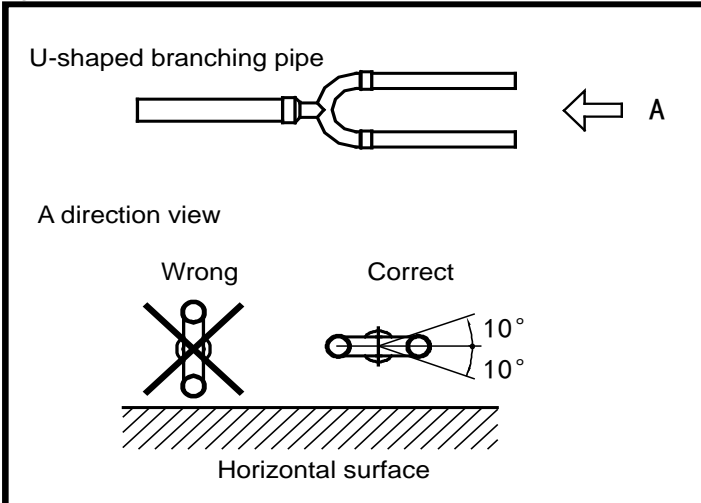

- 6) For avoid oil accumulate at the outdoor unit, please install the branching pipes properly.

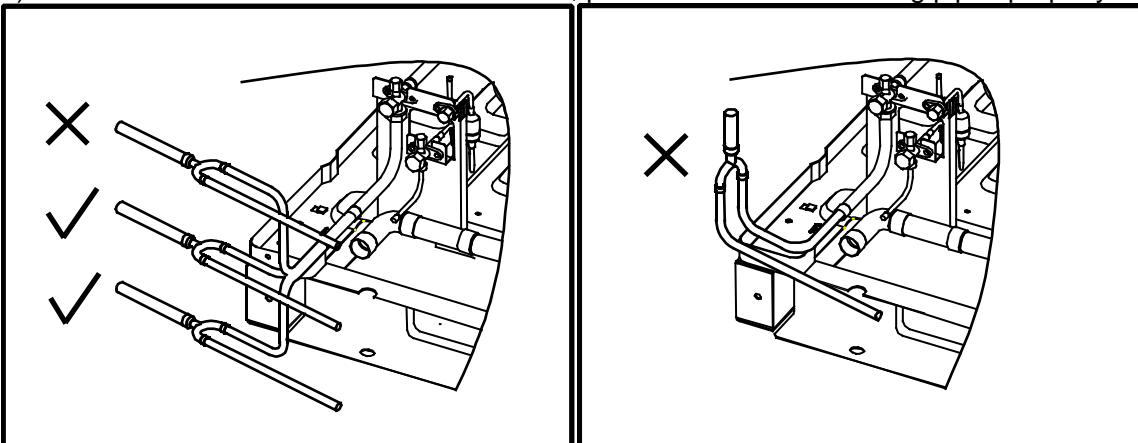

- 7) To ensure even diversion of refrigerant, pay attention to the distance between the branch pipe subassembly and the horizontal straight pipe.
 - a. Ensure that the distance between the bending point of copper pipe and the horizontal straight pipe section of the adjacent branch pipe is larger than or equal to 1m.
 - b. Ensure that the distance between the horizontal straight pipe sections of the two adjacent branch pipes is larger than or equal to 1m.
 - c. Ensure that the distance between the branch pipe and the horizontal straight pipe section used to connect the indoor unit is larger than or equal to 0.5m.

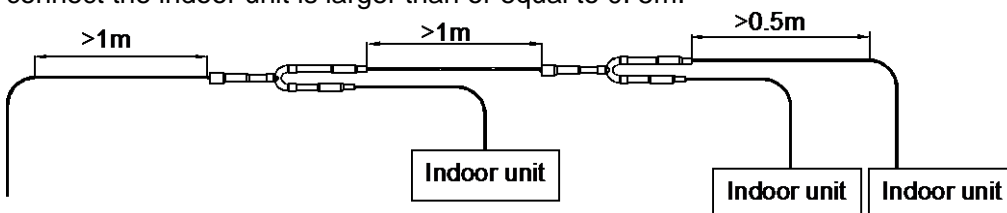

3.1.2. Storage and maintain of copper pipe

3.1.2.1 Pipe carriage and storage

1. Avoid the pipe from bending or deforming during the carriage.
2. Seal the openings of the copper pipe with end cover or adhesive tape during the storage.
3. Place the coil upright to avoid compressing deformation due to self weight.

4. Use wooden support to ensure that the copper pipe is higher than the ground, so as to make the pipe dust-proof and water-proof.
5. Take dust-proof and water-proof measures at both ends of the pipe.
6. Keep the pipes on special bracket or bench at specified place on the construction site.

3.1.2.2 Correct to seal the opening

1. There are two ways for opening sealing:

- 1) Sealing with cover or adhesive tape (suitable for short-term storage)
- 2) Sealing welding (suitable for long-term storage)

Caution: The openings of the copper pipe must be sealed at any time during the construction.

• Method of sealing with cover or adhesive tape

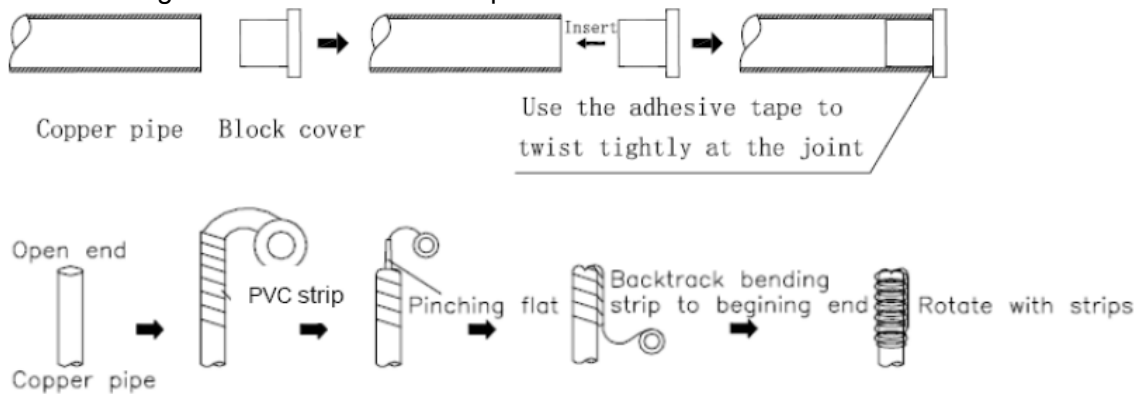

※ It is recommended to seal the openings of the pipe with both cover and adhesive tape.

• Method of sealing welding



2. Special attention:

- 1) When putting the copper pipe through the hole in the wall (dirt is easy to enter into the pipe) .

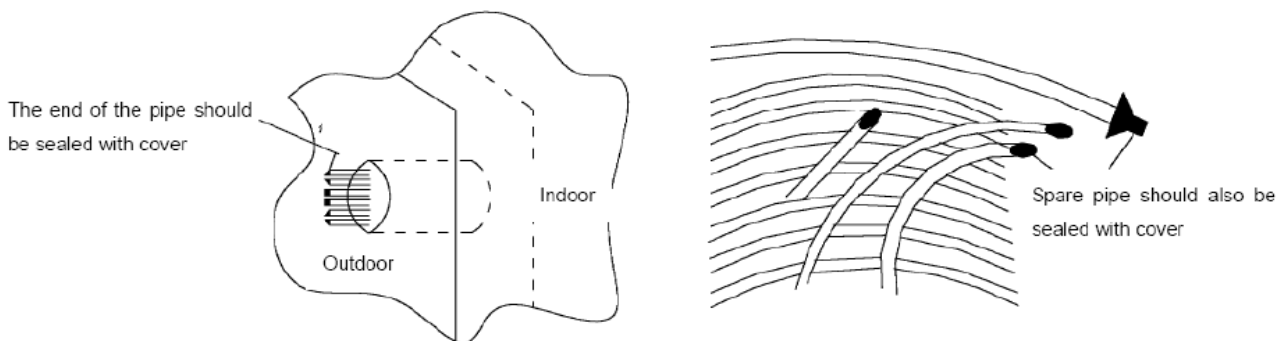

- 2) When the copper pipe goes outside the wall, ensure that no rain water can enter the pipe, particularly when the pipe is placed upright.
- 3) Before completing the pipe connection, seal the openings of the pipe with covers.
- 4) Place the openings of the pipe vertically or horizontally.

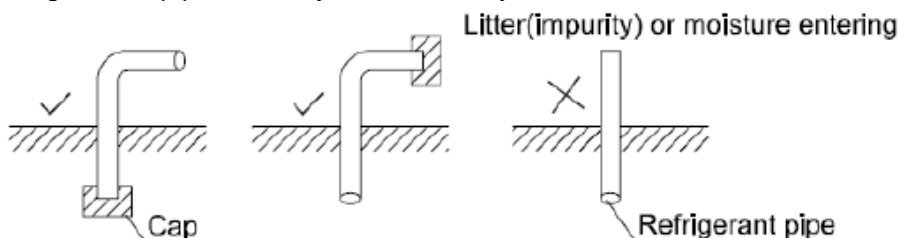

- 5) Before putting the pipe outside the wall, seal the opening of the pipe with a cover.

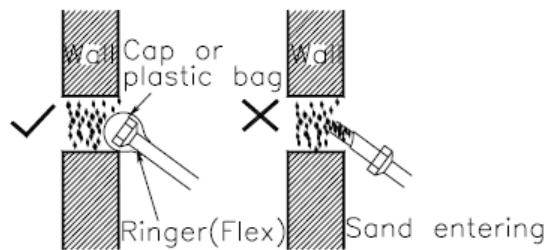

6) Do not place the pipe on the ground directly, or keep it away from ground friction.

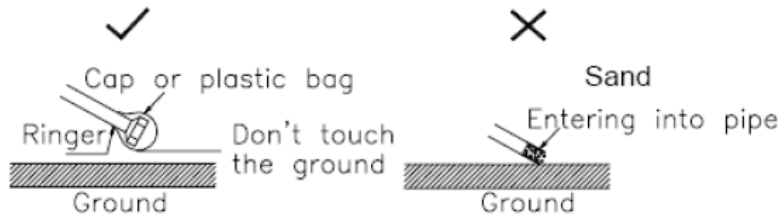

7) When conduct piping on a raining day, remember to seal the openings of the pipe first.

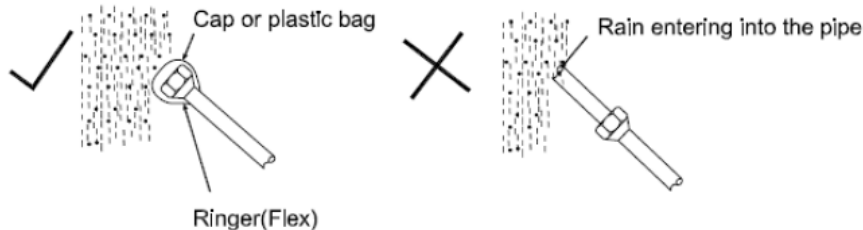

3.1.3 Processing of copper pipe

3.1.3.1 Pipe cutting

1. Tool

Use a pipe cutter instead of a saw or cutting machine to cut the pipe.

2. Correct operation procedure:

Rotate the pipe evenly and slowly, and apply force to it. Cut the pipe off while ensuring that it does not deform.

3. Risk if a saw or cutting machine is used to cut pipe:

Copper chip will enter the pipe (in this case, it will be very hard to clean up), or which may even enter the compressor or blocking the throttling unit.

3.1.3.2 Rectify opening of copper pipe

1. Purpose

Clear out the burr at the opening of the copper pipe, clean the inside of the pipe, and rectify the opening of the pipe, so as to avoid scratch at the opening to be sealed during flaring.

2. Operation procedure

1) Use a scraper to remove the inner spurs. When doing so, keep the opening of the pipe downwards to avoid copper chip from entering the pipe.

2) After the chamfering is completed, use veiling to remove the copper chip out of the pipe.

3) Ensure no scar of produced, so as to avoid the pipe from getting broken during flaring.

4) If the pipe end obviously deforms, cut the end off and then cut the pipe again.

3.1.3.3 Pipe expansion

1. Purpose: Expand the opening of the pipe so that another copper pipe can be inserted to replace direct connection and reduce welding spots.

2. Highlight: Ensure that the connection part is smooth and even; after cutting the pipe off, remove the inner spurs.

3. Operation method: Insert the expanding header of the pipe expander into the pipe to expand the pipe. After completing pipe expansion, rotate the copper pipe a small angle to rectify the straight line scratch left by the expanding header.

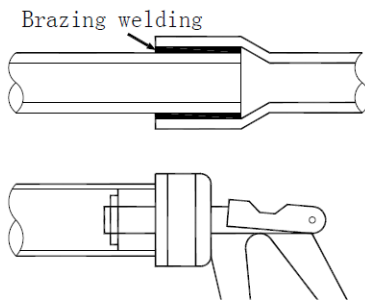

3.1.3.4 Opening bell-mouthed opening

1. Purpose: Flaring Bell-mouthed opening is used for screw thread connection.
2. Highlight:
 - 1) Before performing the Bell-mouthed opening operation, perform fire annealing for the hard pipe.
 - 2) Use pipe cutter to cut pipe to ensure even cross section and avoid refrigerant leakage; do not use a steel saw or metal cutting device to cut pipe, otherwise the cross section will get deformed and the copper chip will enter the pipe.
 - 3) Remove burr carefully to avoid scar on the bell-mouthed opening, which may lead to refrigerant leakage.
 - 4) When connecting pipes, use two spanners (one torque wrench and one non-adjustable spanner).
 - 5) Before conducting opening bell-mouthed, install pipe onto the flaring nut.
 - 6) Use proper torque to tighten the flaring nut.

Pipe Diameter	Torque		Legend
	(kgf-cm)	(N-cm)	
1/4" (6.35)	144~176	1420~1720	
3/8" (9.52)	333~407	3270~3990	
1/2" (12.7)	504~616	4950~6030	
5/8" (15.88)	630~770	6180~7540	
3/4" (19.05)	990~1210	9270~11860	

Caution: When you are tightening the flaring nut with a spanner, the tightening torque will be suddenly increased at a certain point. From this point, further tighten the flaring nut to the angles shown below.

Pipe Diameter	Angle of further tightening	Recommended length of tool lever
3/8" (9.52)	60°~90°	About 200mm
1/2" (12.7)	30°~60°	About 250mm
5/8" (15.88)	30°~60°	About 300mm

7) Check whether the surface of the flaring opening is damaged. The size of the flaring opening is as shown below.

Pipe Diameter	R410A	Legend
	Size of Flaring Opening (A)	
1/4" (6.35)	8.7~9.1	
3/8" (9.52)	12.8~13.2	
1/2" (12.7)	16.2~16.6	
5/8" (15.88)	19.3~19.7	
3/4" (19.05)	23.6~24.0	

Cautions:

- a. Apply some refrigeration oil onto the inner surface and outer surface of the flaring opening, to facilitate the

connection or rotation of the flaring nut, ensure close sticking between the sealing surface and the bearing surface, and avoid pipe bending.

b. Ensure that the flaring opening is not cracked or deformed, otherwise it cannot be sealed or, after the system runs for some time, refrigerant leakage will occur.

3.1.3.5 Pipe bending

1. Method

1) Manual bending: Suitable for thin copper pipes ($\phi 6.35$ - $\phi 12.7$).

2) Mechanical bending: Suitable in a wide range of copper pipes ($\phi 6.35$ - $\phi 67$). Spring bender, manual bender or electric bender is used.

Purpose: Reduce welding joints and required elbows, and improve engineering quality; In order to save material, no joint is needed.

2. Caution

1) When bending a copper pipe, ensure that there is no twinkle or deformation on the inner side of the pipe.

2) When using a spring bender, ensure that the bender is clean before inserting it in the copper pipe.

3) When using a spring bender, ensure that the bending angle does not exceed 90°, otherwise twinkle will appear on the inner side of the pipe, and the pipe may easily get broken.

4) Ensure that the pipe does not sink during the bending process; ensure that the cross section of the bending pipe is larger than 2/3 of the original area, otherwise it cannot be used.

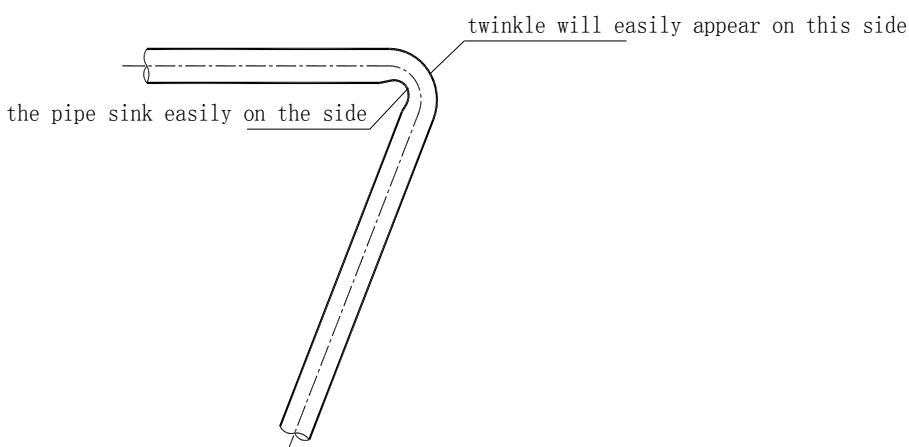

3.1.4 Brazing welding operation

3.1.4.1 Selecting refrigerant pipe

1. All pipe use shall comply with national or local standards (for example, pipe diameter, material, thickness, etc.)

2. Specification: Seamless phosphorus to oxygenate copper pipe

3. Try best to use straight pipe or coil and avoid too much brazing welding.

Note: Select the pipes according to the pipe diameters shown below (O—coil, 1/2H—straight pipe)

Outer Diameter	Material	Minimum Thickness	Outer Diameter	Material	Minimum Thickness	Outer Diameter	Material	Minimum Thickness
$\phi 6.35$	O	0.8	$\phi 19.0$	O	1.0	$\phi 38.0$	1/2H	1.5
$\phi 9.52$	O	0.8	$\phi 22.0$	1/2H	1.2	$\phi 45.0$	1/2H	1.5
$\phi 12.7$	O	0.8	$\phi 25.0$	1/2H	1.2	$\phi 54.0$	1/2H	1.8
$\phi 15.9$	O	1.0	$\phi 28.6$	1/2H	1.3	$\phi 67.0$	1/2H	1.8

3.1.4.2 Nitrogen filling for protecting copper pipe during brazing welding

1. Purpose: Avoid oxide scale from appearing on the inner wall of the copper pipe in the high temp.

2. Risks of non-protective welding:

If no sufficient nitrogen is charged into the refrigerant pipe being welded, oxides will be generated on the inner wall of the copper pipe. These oxides will block the refrigerant system, which will lead to all kinds of malfunctions such as burn-out the compressor, poor cooling efficiency.

To avoid these problems, charge nitrogen continuously into the refrigerant pipe during the brazing welding, and ensure that the nitrogen passes through the operating point until the welding is completed and the copper pipe cools down completely. The schematic diagram for nitrogen charging is shown below.

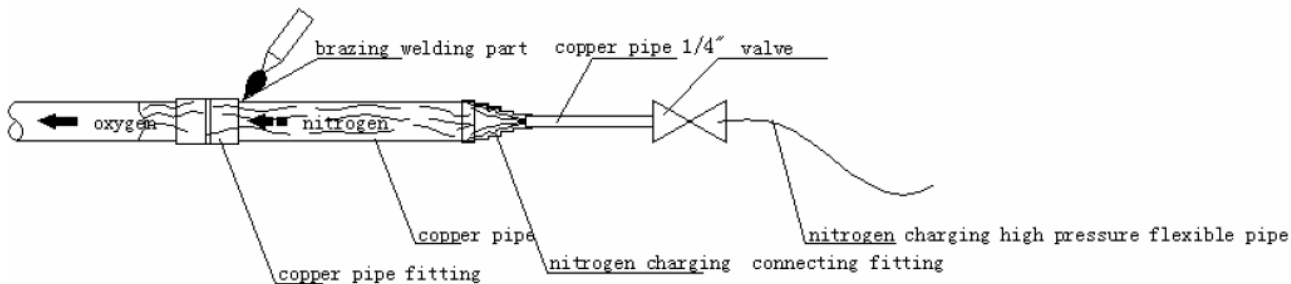

3. Making Nitrogen-Charging Pipe Joint

When welding the pipe joint, connect the nitrogen-charging joint to the pipe fittings to be welded. The nitrogen-charging joint is shown below:

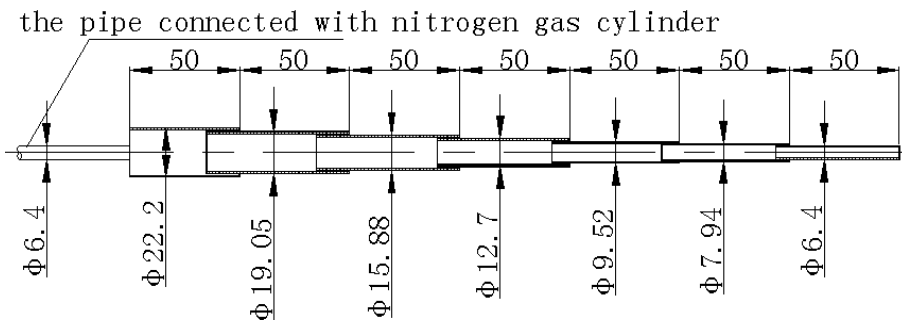

4. Cautions for Welding Pipe Fittings

- 1) Adopt transition pipe.
- 2) Charge nitrogen from the side of the short pipe, because short distance may result in perfectible nitrogen replacement effect.

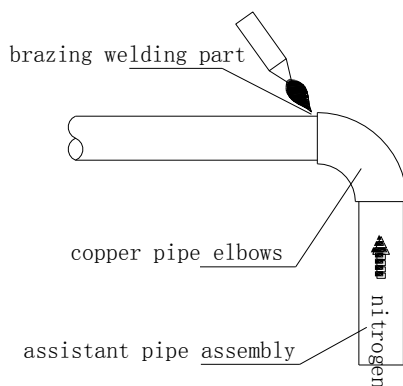
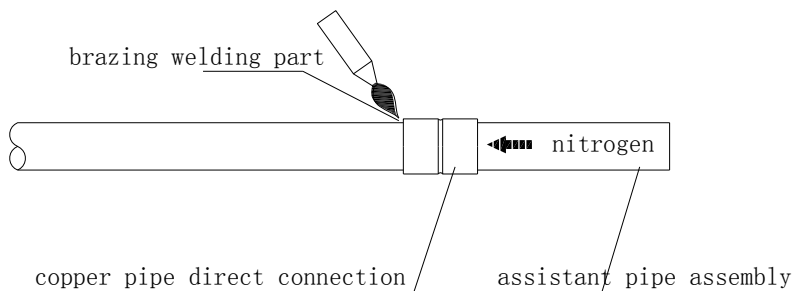

5. Standard operation of Brazing Welding

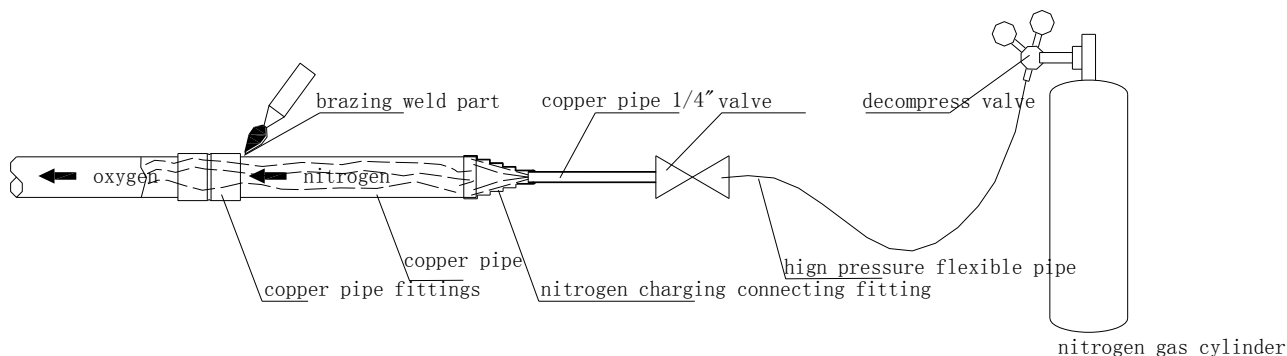

6. Highlight

- 1) Control the nitrogen pressure to be about 0.2-0.3kgf/cm² during the welding.
- 2) Ensure the gas is nitrogen; oxygen will easily leads explosion, so it is forbidden.
- 3) Use pressure reducing valve, and control the pressure of the charged nitrogen to be about 0.2kg/ cm².
- 4) Select a proper position for charging nitrogen.
- 5) Ensure that the nitrogen passes through the welding spots.
- 6) If the pipeline between the position for charging nitrogen and the welding spot is rather long, ensure that the nitrogen is charged for sufficient time so as to discharge all the air from the welding spot.
- 7) After completing the welding, charge the nitrogen continuously until the pipe cools down completely.
- 8) Try best to conduct welding downwards or horizontally and avoid face-down welding.

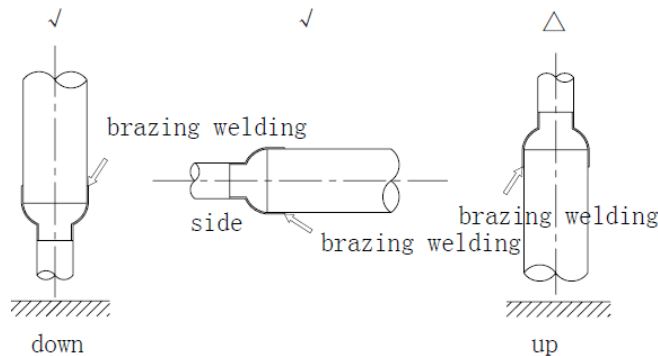

7. Cautions

- 1) Take fire-prevention measures when conducting welding (ensure that a fire extinguisher is available beside the operating position).
- 2) Avoid getting burnt.
- 3) Pay attention to the fit gap of the position where the pipe is inserted.

Note: The follow table shows the relation between the minimum embedded depth and gap at the copper pipe joint.

Type	Outer Diameter of Pipe (D) (mm)+	Minimum Inlaid Depth (B) (mm)	Gap A—D (mm)
	5<D<8	6	0.05—0.21
	8<D<12	7	
	11<D<16	8	
	16<D<25	10	0.05—0.27
	25<D<35	12	
	35<D<45	14	

3.1.5 Pipe cleaning out

3.1.5.1 Flushing copper pipe

1. Function: use pressure gas to flush pipeline (raw material or welded assembly) for eliminating dust, trash and moisture. Solid impurity is hard to be washed out, so special attention shall be drawn to the protection of copper pipeline during construction.
2. Purpose
 - 1) Eliminate oxide powder or part oxide layer in copper pipe.
 - 2) Help to clear out dirt and humidity in pipe.
3. Risk in case of no flushing:
If the remaining solid impurity and moisture in pipeline could not be eliminated effectively, serious

malfunctions shall happen, such as ice blockage, dirt blockage and compressor being jammed.

3.1.5.2 Procedure of flushing

1. Mounting pressure adjusting valve on nitrogen gas cylinder. The applied gas must be nitrogen. If adopting polytetrafluoro ethylene or carbon dioxide, there is a risk of condensation. If using oxygen, there is a risk of explosion.
2. Making use of inflation tube to connect outlet of pressure adjusting valve and inlet at liquid pipe side of outdoor unit.

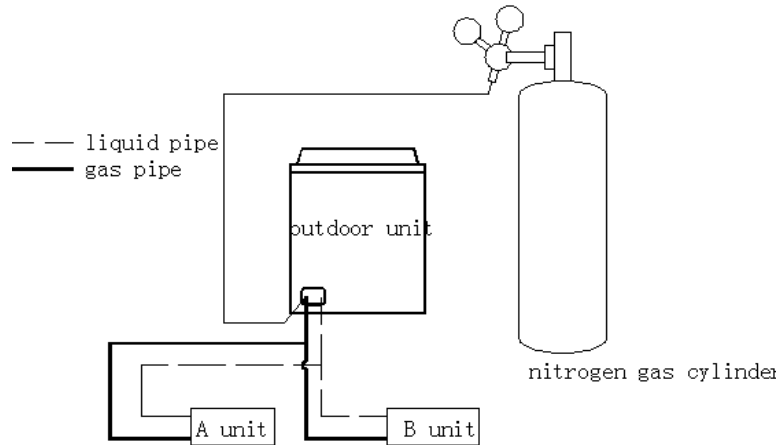

3. Use blind plug to block all connectors of liquid side copper line (including unit B) soundly, excluding indoor unit A.
4. Turn on nitrogen gas cylinder valve, and then pressurize to 5kgf/cm² gradually through adjusting valve.
5. Check whether nitrogen has passed through the liquid pipe at the side of indoor unit A. Connector at the side of indoor unit body has been covered by tape to prevent the entering of dirt.

3.1.5.3. Detailed steps for flushing

1. Hold proper blockage material (such as block bag and white cotton) to push against the main pipe opening at the gas side of indoor unit.
 2. When pressure increases and hands could not push against the opening, suddenly release pipe opening (flushing for first time).
- Repeat above step1 and step 2 to re-flush dirt (flushing for multi-times)

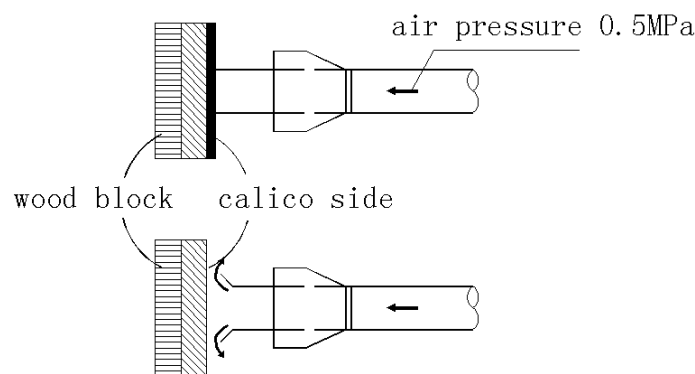

3. During flushing, place a piece of white cotton at the pipe opening for checking, and you shall find some humidity occasionally.
- Way of thoroughly drying pipeline is as follows:
- 1) Making use of nitrogen gas to flush the inner part of pipe until no dirt and humidity.
 - 2) Carry out vacuum drying operation (see vacuum drying of MDV refrigerant piping in detail).
 - 3) Shut down nitrogen main valve.
 - 4) Repeat above operations to the connected copper pipe of all indoor units.
 - 5) Sequence of flushing: when pipeline has been connected to system, sequence of flushing is from far to near, that is, in light of principal unit, flushing from the farthest pipe opening to principal unit in turn (i.e. 1)-2)-3)-4)-5)-6)).

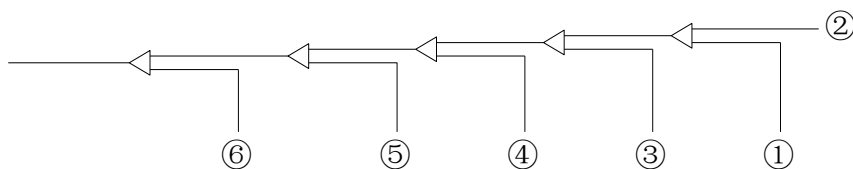

Caution: When flushing one pipe opening, block all pipe openings which are connected to this opening.
 6) After finishing flushing, seal soundly all openings linked with atmosphere to prevent the entering of dust, trash and moisture.

3.1.6 Installation highlight of pipe system

- 1) Pipe between outdoor units must install horizontally, the mid-connecting pipe between those pipes aren't allowed downward drop.
- 2) All pipes between outdoor units cannot be higher than the outdoor units' outlet.

The right installation type:

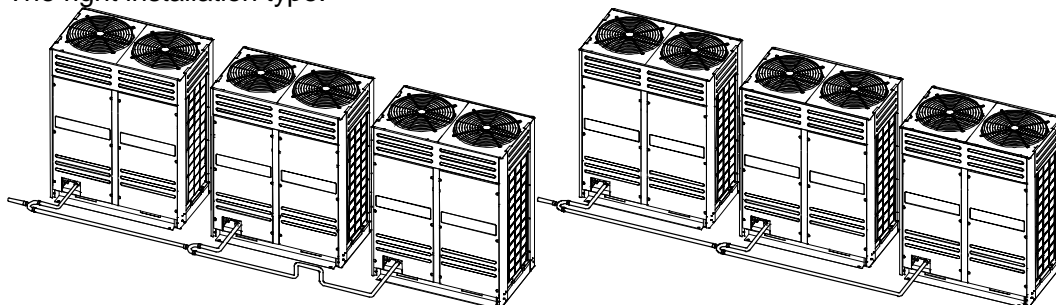

The wrong installation type:

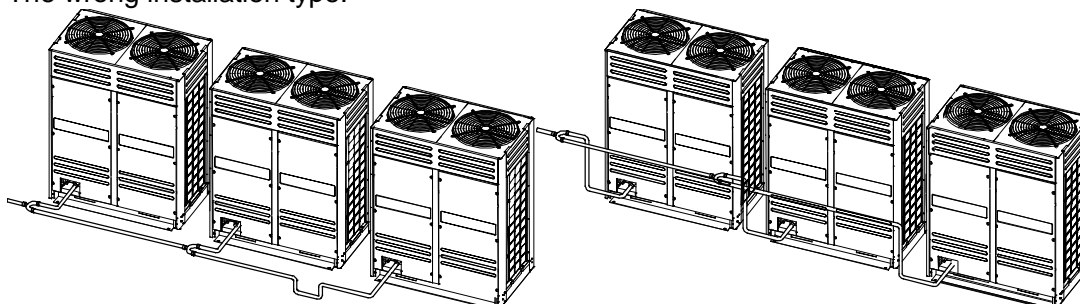

3.2. Air Tight Test

3.2.1 Purpose and operation procedure of air tightness test

3.2.1.1 Purpose

Search leak source, make sure there is no leakage in system to prevent system fault due to leakage of refrigerant.

3.2.1.2 Operation tips

Subsection detection, overall pressure-keeping, grading pressurization.

3.2.1.3 Operation procedure

- 1. After piping of indoor unit has been connected, weld port of high-pressure side piping.
- 2. Weld low-pressure side piping with connector for pressure gauge together.
- 3. Charge nitrogen slowly into pressure gauge connector to conduct air tightness test.

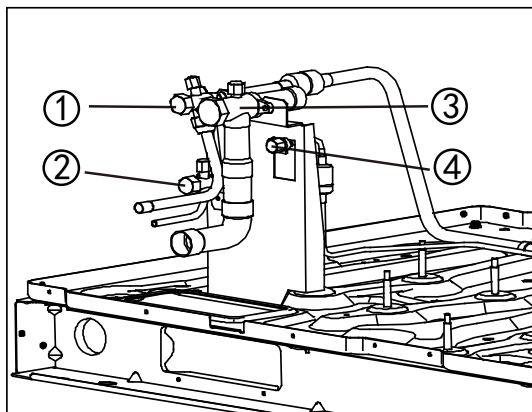

8~16HP

Note: For a single modular that is not necessary to connect with oil balancer.

- ① Liquid pipe stop valve
- ② Oil balancer
- ③ Gas pipe stop valve
- ④ Gauge point (Use for detecting pressure and refrigerant)

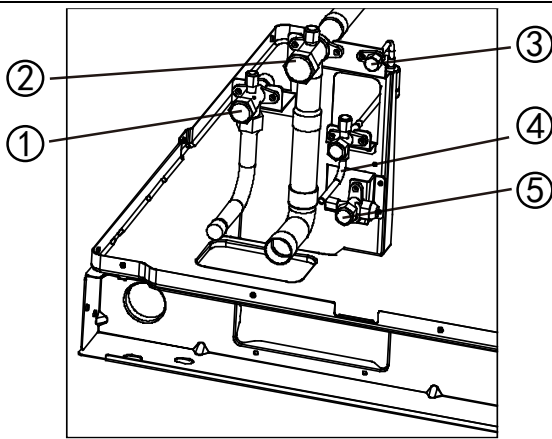

18HP

- ① Liquid pipe stop valve
- ② Gas pipe stop valve
- ③ Gauge point (Use for detecting pressure and refrigerant)
- ④ Oil balancer
- ⑤ Oil drain valve

3.2.2 Operation of air tightness test

3.2.2.1 Operation procedure

1. When conducting air tightness test, make sure that gas pipe and liquid pipe are kept in full-shut status; otherwise, nitrogen might enter the circulation system of outdoor unit. Both gas valve and liquid valve need to be strengthened before pressurization.
2. Each refrigerant system shall be slowly pressurized from the two sides of gas pipe and liquid pipe.
3. Make use of dry nitrogen as medium to conduct air tightness test. Phase-in control diagram of pressurization is as follows:

No.	Phase (phase-in pressurization)	Criteria
1	Phase 1: appear large leakage after over three minutes of pressurization with 3.0kgf/cm ² .	No pressure drop after modification
2	Phase 2: appear major leakage after over three minutes of pressurization with 15. 0kgf/cm ² .	
3	Phase 3: appear small leakage after over 24 hours of pressurization with R410A: 40.0kgf/cm ² .	

3.2.2.2 Pressure observation

1. Pressurize to regulated value and maintain 24 hours. When modifying pressure according to variation of temperature, it is qualified if pressure drop does not happen. If pressure falls, find out the leak source and modify it.

2. Modification method

When ambient temperature difference is ±1℃, the pressure difference shall be ±0.1 kgf/cm².

Modification formula: Real value = pressure of pressurization + (temperature of pressurization –temperature during observation) x 0.1kgf/cm²

You can find out whether the pressure drops or not by comparing the modification value with pressurization value.

3. General ways for searching leak source

Conduct detection through three phases; find out leak source when pressure drop happens.

- 1) Audition detection-----hear large leakage sound
- 2) Hand-touching detection-----place hand at the joint of pipeline to feel whether there is leakage
- 3) Soap water detection-----bubbles shall burst out from leak source.
- 4) Detection by use of halogen leak detector

Using halogen leak detector when finding out pressure drop but not finding the leak source.

- a. Keep nitrogen at 3.0kgf/cm².
- b. Supplement refrigerant to 5.0kgf/cm².
- c. Use halogen leak detector, methane leak detector and electric leak detector for detection.
- d. If the leak source still could not be found, continuously pressurize to 40.0kgf/cm² (R410A) and then detect again.

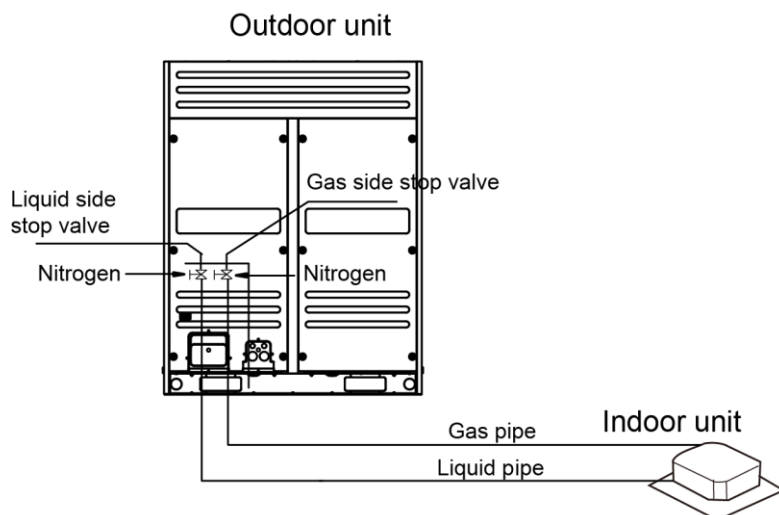

4. Caution

- 1) The air tightness test is conducted by pressurize nitrogen (R410A system: 40kgf/cm^2).
- 2) It is not allowed to adopt oxide, flammable gas and toxic gas to conduct air tightness test.
- 3) Before pressure-keeping reading, let it rest for several minutes till pressure is stable, to record temperature, pressure value for future modification.
- 4) After pressure-keeping is over, release system pressure to $5\sim 8\text{kgf/cm}^2$ and then conduct pressure-keeping and storage.
- 5) If pipeline is too long, conduct phase-in detection.
 - a. Inner side of pipeline
 - b. Inner side of pipeline + upright
 - c. Inner side of pipeline + upright + outer side of pipeline

3.3 Vacuum Drying

3.3.1 Purpose and highlights of vacuum drying

3.3.1.1 Purpose of vacuum drying

1. Dehumidify the system to prevent ice-blockage and copperizing. Ice-blockage shall cause abnormal operation, while copperizing shall damage compressor.
2. Eliminating the non-condensable gas of system to prevent oxidizing components, system pressure fluctuation, and bad heat exchanging during the system operation.
3. Detect leak source from reverse rotate.

3.3.1.2 Selection of vacuum pump

1. The limit of vacuum degree is below -756mmHg .
2. The discharge of vacuum pump is over 4L/s .
3. The precision of vacuum pump is over 0.02mmHg .

Highlights of R410A system:

After the vacuum process of R410A refrigerant circulation is over, vacuum pump stops running and the lubricant in vacuum pump shall flow back to air conditioning system, for the inner of pump soft pipe is in vacuum status. In addition, same situation shall happen if vacuum pump suddenly stops during operation. At this moment, different oils will mix, which induce the refrigerant circulating system to malfunction, so it is recommended to use one-way valve to prevent reverse flow of oil in vacuum pump.

3.3.1.3 Vacuum drying for pipe

Vacuum drying: Use vacuum pump to make the moisture (liquid) in pipeline change into steam, which will eliminate the moist of the pipeline and keep drying of pipe inner. Under atmospheric pressure, water's boiling point (steam temperature) is 100°C , while its boiling point will decline when using vacuum

pump reduce the pipeline pressure to vacuum. When the boiling point declines under outdoor temperature, moisture in pipe shall be evaporated.

Boiling Point of Water (°C)	Air Pressure (mmHg)	Vacuum Degree (mmHg)	Boiling Point of Water (°C)	Air Pressure (mmHg)	Vacuum Degree (mmHg)
40	55	-705	17.8	15	-745
30	36	-724	15	13	-747
26.7	25	-735	11.7	10	-750
24.4	23	-737	7.2	8	-752
22.2	20	-740	0	5	-755
20.6	18	-742			

3.3.2 Operation procedure for vacuum drying

3.3.2.1 Methods of vacuum drying

By different construction environment, there are two kinds of vacuum drying ways: ordinary vacuum drying and special vacuum drying.

3.3.2.1.1 Ordinary vacuum drying

- 1) Firstly, connect the pressure gauge to the infusing mouth of gas pipe and liquid pipe, keep vacuum pump running for above 2 hours, and it is quality that vacuum degree of vacuum pump is below -755mmHg.
- 2) If the vacuum degree of vacuum pump could not be below -755mmHg after 2 hours of drying, system will continue drying for one hour.
- 3) If the vacuum degree of vacuum pump could not be below -755mmHg after 3 hours of drying, please check the system leakage source.
- 4) Vacuum placement test: when the vacuum degree reaches -755mmH, keep rest for 1 hour. If the indicator of vacuum gauge does not go up, it is qualified. If going up, it indicates that there is moisture and leak source.
- 5) Vacuum drying shall be conduct from liquid pipe and gas pipe simultaneously. There are a lot of functional parts like valves, which could shut down the gas flow midway.

3.3.2.1.2 Special vacuum drying

This kind of vacuum drying method shall be adopted when:

- 1) Finding moisture during flushing refrigerant pipe.
- 2) Conducting construction on rainy day, because rain water might penetrated into pipeline.
- 3) Construction period is long, and rain water might penetrated into pipeline.
- 4) Rain water might penetrate into pipeline during construction.

Procedures of special vacuum drying are as follows:

- a. The first vacuum drying 2 hours.
- b. The second vacuum damage, filling nitrogen to 0.5Kgf/cm².

Because nitrogen is dry gas, vacuum damage could achieve the effect of vacuum drying, but this method could not achieve drying thoroughly when there is too much moisture. Therefore, special attention shall be drawn to prevent the entering of water and the formation of condensate water.

- c. The second vacuum drying 1 hour.

It is qualified when vacuum degree is under -755mmHg; if the vacuum degree is still above -755mmHg within 2 hours drying, please repeat the procedures of “vacuum damage---vacuum drying”.

- d. Vacuum placement test: when the vacuum degree reaches -755mmH, keep rest for 1 hour. If the indicator of vacuum gauge does not go up, it is qualified. If going up, it indicates that there is moisture and leak source.

3.4 Recharge Refrigerant

3.4.1 Operation procedure for recharging refrigerant

3.4.1.1 Operation procedure

Calculate the required refrigerant volume by the length of liquid pipe → recharging refrigerant.

※The refrigerant volume from factory does not include the recharged amount of the pipeline extending.

3.4.1.2 Detailed steps for recharging refrigerant

1. Make sure vacuum drying is qualified before recharging refrigerant.
2. Calculate the required refrigerant volume by the diameter and the length of liquid pipe.
3. Use electronic scale or fluid infusion apparatus to weight there charged refrigerant volume.
4. Use soft pipe to connect refrigerant cylinder, pressure gauge, and examine valve of outdoor unit. And recharge with liquid mode. Before recharging, eliminate the air in the soft pipe and pressure gauge's pipe.
5. After finishing the recharging, by the gas leak detector or soap water, to detect whether there is refrigerant leakage in expansion part of indoor and outdoor units.
6. Write the recharged refrigerant volume in the indicating plate of outdoor unit.

Caution

- 1) The recharged refrigerant volume must be calculated according to the formula in the technical reference of outdoor unit. It isn't allowed to calculate by running current, pressure and temperature. Because current and pressure is changeable due to the difference of temperature and length of pipeline.
- 2) In the cold ambient, use warm water and hot wind to warm up refrigerant storage cylinder, and don't allow heating up directly by flame.

3.4.1.3 Recharging R410A refrigerant

If R410A refrigerant is adopted, the tool shall be different. Confirm the following items before recharged:

- 1) The different vacuum pump with one-way valve.
- 2) The different pressure gauge: the nut of connector and pressure scale are different.
- 3) The different recharging soft pipe and connector.
- 4) The charging method is different. Recharge into the outdoor unit with liquid phase.
- 5) The different leak detector.

3.4.2 Calculating the recharged refrigerant volume

Calculate the recharged refrigerant volume by the length and diameter of liquid pipe of indoor units

R410A			
Diameter of Liquid Pipe	Equivalent Refrigerant for Pipe Length of 1m (kg/m)	Diameter of Liquid Pipe	Equivalent Refrigerant for Pipe Length of 1m (kg/m)
Φ6.4	0.023	Φ19.1	0.270
Φ9.5	0.060	Φ22.2	0.380
Φ12.7	0.120	Φ25.4	0.520
Φ15.9	0.170	Φ28.6	0.680

Calculating formula (R410A):

The recharged volume: $R \text{ (Kg)} = (L1 \times 0.023 \text{ kg/m}) + (L2 \times 0.060 \text{ kg/m}) + (L3 \times 0.120 \text{ kg/m}) + (L4 \times 0.180 \text{ kg/m}) + (L5 \times 0.270 \text{ kg/m}) + (L6 \times 0.380 \text{ kg/m}) + (L7 \times 0.520 \text{ kg/m}) + (L8 \times 0.680 \text{ kg/m})$

L1: Actual total length of Φ6.4 liquid pipe (m); L2: Actual total length of Φ9.5 liquid pipe (m);

L3: Actual total length of Φ12.7 liquid pipe (m); L4: Actual total length of Φ15.9 liquid pipe (m);

L5: Actual total length of Φ19.1 liquid pipe (m); L6: Actual total length of Φ22.2 liquid pipe (m);

L7: Actual total length of Φ25.4 liquid pipe (m); L8: Actual total length of Φ28.6 liquid pipe (m)

4. Drainage Pipe Engineering

4.1 Installation Highlights of Drainage Pipe

4.1.1 Installation principle of drainage pipe:

1) Slope; 2) reasonable pipe diameter; 3) nearby discharge

4.1.2 Installation highlights of drainage pipe:

1. Before installing condensate water pipeline, determine its route and elevation to avoid intersection with other pipelines and ensure slope is smooth and straight.

2. Make sure that the two horizontal fluid pipes shall avoid encountering, and preventing flow backwards and drainage difficulty.

a. Correct connection:

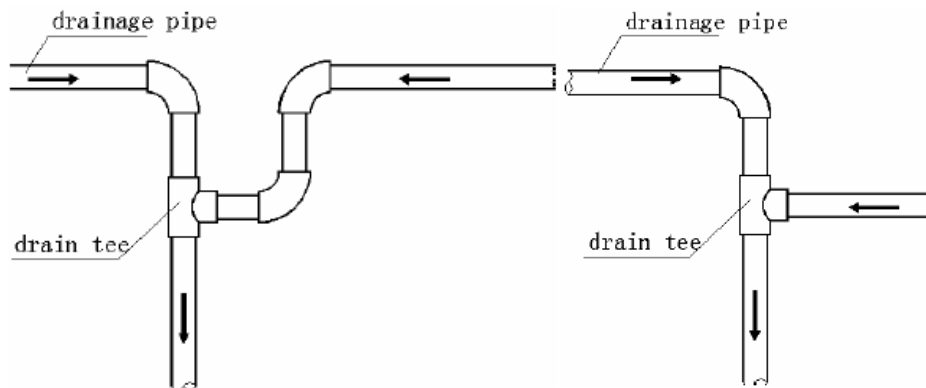

b. Incorrect connection:

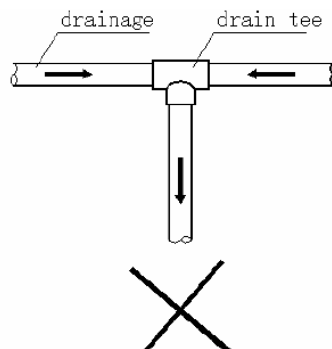

Advantages of correct connection:

1. Do not cause flow backwards of one pipe.
2. The slope of two pipes can be regulated separately.

Disadvantages of incorrect connection:

1. Interfere drainage.
2. The side of branch pipe with large quantity of fluid volume will flow to the side with small quantity, thus leading to the water backwards of branch pipe with small quantity.

3. Suspender gap:

In general, the horizontal gap is 0.8m-1m and the vertical gap is 1.5m-2.0m. Each vertical pipe shall be equipped with not less than two suspenders. Overlarge suspender gap for horizontal pipe shall create bending, thus leading to air resistance.

4. The highest point of drainage pipe shall be designed with air hole to ensure that condensate water could be discharged smoothly. The outlet air hole shall face down to prevent dirt entering pipe.

5. After finishing connection, conduct water passing test and overflowing water test to pipelines to check the smoothness of drainage and leakage of pipeline system.

6. Use specific glue to adhesive the seam of thermal insulation materials, and then bind with rubber or

plastics adhesive tape. The width of the adhesive tape shall not be less than 50mm to ensure fastness and prevent condensation.

7. The drainage pipe of air conditioner shall be installed separately with other waste pipe, rainwater pipe and other drainage pipe in building.

8. The slope of drainage pipe shall be kept above 1/100.

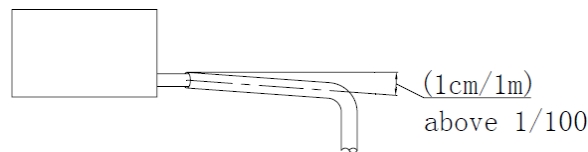

9. In case 1/100 slope can not need, consider to use larger-sized pipe and use its diameter To create slope.

10. Conflux towards horizontal pipe shall come from upside as much as possible. If it comes from transverse route, reflux is easy to be created.

11. The end of drainage pipe shall not contact with ground directly.

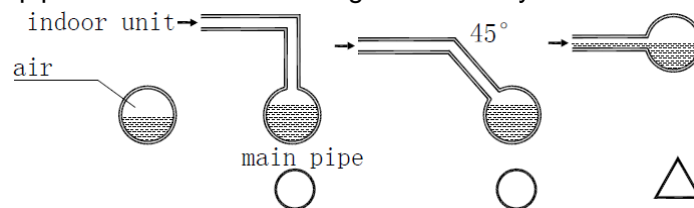

4.1.3 Caution

1. The drainage pipe diameter shall meet the draining requirement of indoor unit.
 2. The outlet air vent cannot be installed nearby the lifting pump of the indoor unit.
 3. Check whether condensate water pump can be started up and shut down normally by infusing water into the water-containing plate of indoor unit and powering on.
 4. All joints shall be firm (particularly PVC pipe).
 5. The drainage pipe is not allowed to turn to adverse slope, horizontal, and bending.
 6. Dimension of drainage pipe shall be not less than the connecting mouth size of drain piping to indoor unit.
 7. Work out thermal insulation of drainage pipe, otherwise it is easy to produce condensation. Thermal insulation processing shall be continued to the connecting part of indoor unit.
 8. Indoor units with different draining pattern shall not share the same concentrated drainage pipe.
 9. Discharge of condensate water cannot influence normal life and working of other people.
 10. As for long drainage pipe, hanging bolt shall be used to ensure 1/100 slope without bending PVC pipe.
- ※ The support gap of horizontal pipe is 0.8-1.0mm. If the gap is too large, it shall produce bending and air resistance, while air resistance could seriously influence smoothness of water flow to cause abnormal water level. As shown in following figure:

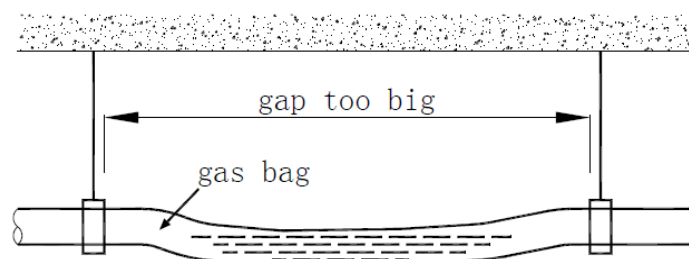

4.2 Water Storing Elbow of Drainage Pipe

4.2.1 To indoor unit with large negative pressure at the outlet of water-containing plate, the drainage

pipe must be equipped with water storing elbow.

Function of water storing elbow:

When indoor unit is in motion, prevent generating negative pressure to cause drainage difficulty or blow water out of the air outlet.

Installation of water storing elbow:

1. Install water storing elbow as shown in following figure: H shall be above 50mm.
2. Install one water storing elbow for each unit.
3. When installation, consider it shall be convenient in future clean.

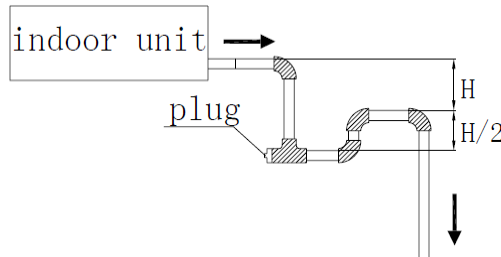

4.3 Concentrated Drainage Pipe

4.3.1 Pipeline diameter of concentrated drainage pipe

Select drainage pipe diameter according to indoor unit's combined flow volume.

E.g. If one 1HP unit with 2L/h discharging condensate water, the calculation of the combined flow volume of three 2HP units and two 1.5HP units is: $2HP \times 2L/h \times 3 + 1.5HP \times 2L/h \times 2 = 18L$

4.3.2 Relation between horizontal pipeline diameter and permitted displacement of condensate water

PVC piping	Inner diameter of piping(reference value: mm)	Inner diameter of piping(mm)	Permitted displacement(1/h)		Remark
			Slope 1:50	Slope 1:100	
PVC25	19	20	39	27	(Reference value)could not used for confluence pipe
PVC32	27	25	70	50	
PVC40	34	31	125	88	Could be used for confluence pipe
PVC50	44	40	247	175	
PVC63	56	51	473	334	

Attention: through converge point need use PVC40 or larger pipe.

4.3.3 Relation between vertical pipeline diameter and displacement of condensate water

PVC piping	Inner diameter of piping(reference value: mm)	Inner diameter of piping(mm)	Permitted displacement(1/h)	Remark
PVC25	19	20	220	(Reference value)could not used for confluence pipe
PVC32	27	25	410	
PVC40	34	31	730	Could be used for confluence pipe
PVC50	44	40	1440	
PVC63	56	51	2760	
PVC75	66	67	5710	
PVC90	79	77	8280	

Attention: through converge point need use PVC40 or larger pipe.

4.3.4 Operation process of concentrated drainage

Install indoor unit → connect drainage pipe → water passing test and overflowing water test → thermal insulation of drainage pipe

Caution:

- 1) Increase drainage point as much as possible and reduce quantity of connected indoor units, to ensure horizontal main drainage pipe not be too long.
- 2) Units with drainage pump and natural drainage shall converge to different drainage system separately.
- 3) Add two elbows at air outlet, and make sure its mouth faces down to prevent dirt and so on dropping into pipe to create blockage.

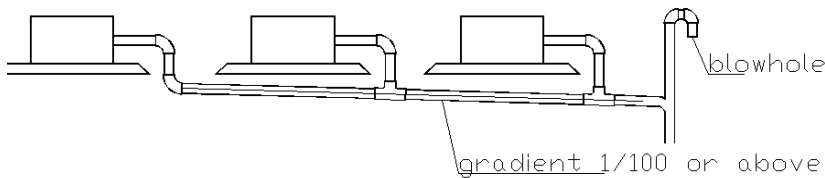

4.4 Lifting of Drainage Pipe (for the Unit with Lift Pump)

4.4.1 Installation of lift pipe

1. When connecting drainage pipe with indoor unit, use pipe clamp shipped with unit to fix. Glue splicing is not permitted for ensuring convenience in repairing.
2. To ensure 1/100 slope, total lift height of drainage pipe (H) shall depend on indoor unit's pump, and do not set vent pipe on the lifting pipe section. After lifting vertically, immediately place down inclined, otherwise it will cause error operation of switch at water pump. The connecting method is shown as follows:

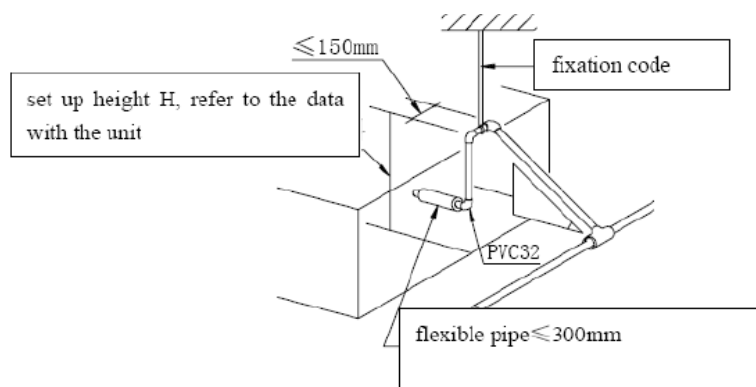

Note: Air outlet could not be installed on the lifting part; otherwise water shall be discharged to ceiling or could not be discharged.

4.5 Overflowing Water Test and Water Passing Test

4.5.1 Overflowing water test

After finishing the construction of drainage pipe system, fill the pipe with water and keep it for 24 hours to check whether there is leakage at joint section.

4.5.2 Water passing test

1. Natural drainage mode

Infuse water-containing plate with above 600ml water through check port slowly, and observe transparent hard pipe at drainage outlet to confirm whether it can discharge water.

2. Pump drainage mode

- 1) Remove plug of water level switch, remove water-finding cover and slowly infuse water-containing plate with about 2000ml water through water-finding port to prevent touching the motor of drainage pump.

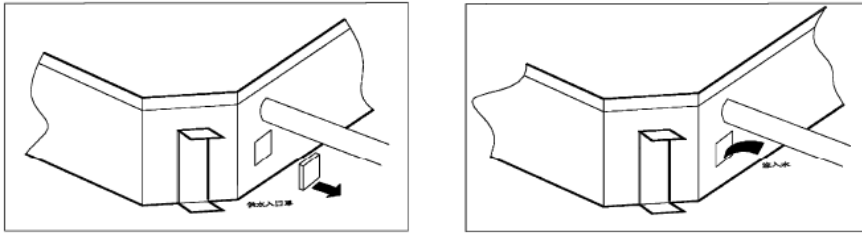

2) Power on and let the air conditioner operate for cooling. Check operation status of drainage pump, and then turn on water level switch, check operation sound of pump and observe transparent hard pipe at drainage outlet to confirm whether it can discharge water. (In light of the length of drainage pipe, water shall be discharged after delaying about 1 minute)

3) Stop the operation of air conditioner, turn down power supply and put water-finding cover to the original place.

a. After stopping the operation of air conditioner, check whether there is something abnormal 3 minutes later. If drainage pipe have not been distributed properly, over back-flow water shall cause the flashing of alarm indicator at remote-controlled receiving board and even water shall run over the water-containing plate.

b. Continuously add water until reaching alarm water level, check whether the drainage pump could discharge water at once. If water level does not decline under warning water level 3 minutes later, it shall cause shutdown of unit. When this situation happens, normal startup shall be carried out by turning down power supply and eliminating accumulated water.

Note: Drain plug at the main water-containing plate is used for eliminating accumulated water in water-containing plate when maintaining air conditioner fault. During normal operation, the plug shall be filled in to prevent leakage.

5. Duct Engineering

5.1 Fabrication of Duct

1. The material, specification, performance and thickness of metal duct should be in accordance with the relevant regulations of present National Products Standard. The thickness of steel sheet or galvanized steel sheet should not be less than the regulation in table below:

Thickness of steel sheet duct (mm)

Diameter(D) or edge length (b) of duct	Circular duct	Rectangle duct	
		Middle/low pressure system	High pressure system
$D(b) \leq 320$	0.5	0.5	0.75
$320 < D(b) \leq 450$	0.6	0.6	0.75
$450 < D(b) \leq 630$	0.75	0.6	0.75
$630 < D(b) \leq 1000$	0.75	0.75	1
$1000 < D(b) \leq 1250$	1	1	1

2. The material, specification, performance and thickness of non-metal duct should be in compliance with design and regulations of present National Products Standard.

3. The body, frame, fixing material and sealed cushion of fire-proof air duct should be made of non-combustible materials. Its fire resistance rating should be in accordance with the design requirement.

4. The sheathing of composite duct should be made of non-combustible materials. Inner insulation material should be no burning or burning retardant with rating B1, and no harm to people's body.

5. The permitting deviation to outer diameter or long edge of duct: when no more than 300mm, it is 2mm; when more than 300mm, it is 3mm. The permitting deviation of pipe end flatness is 2mm.

Discrepancy between two diagonal lines of rectangle duct shall not be more than 3mm. Discrepancy between two diameters of any cross-cut circular flange shall not be more than 2mm.

5.2 Connection of Duct

1. Connection of metal duct

1) The seam of duct board splice should be stagger and cross-seam is not allowed.

2) Specification of metal duct flange shall not be less than the data as shown in table below.

Specification to flange and bolt of circular metal duct (mm)

Diameter of duct(D)	Specification of flange		Specification of bolt
	Flat steel	Angle steel	
$D \leq 140$	20×4	-	M6
$140 < D \leq 280$	25×4	-	
$280 < D \leq 630$	-	25×3	
$630 < D \leq 1250$	-	30×4	M8
$1250 < D \leq 2000$	-	40×4	

Specification to flange and bolt of rectangle metal duct (mm)

Dimension of long edge of duct(b)	Specification of flange(angle steel)	Specification of bolt
$b \leq 630$	25×3	M6
$630 < b \leq 1500$	30×3	M8
$1500 < b \leq 2500$	40×4	
$2500 < b \leq 4000$	50×5	M10

3) Diameter of bolt and rivet to duct flange for middle/low pressure system should be no more than 150mm.

As for duct of high pressure system, it should be no more than 100mm.

- 4) Four angles of rectangle duct flange should be designed with screw hole.
- 5) When improving the strength of duct flange position by adopting reinforcement method, the applied condition corresponding to flange specification could be extended.

2. Connection of nonmetallic duct

Specification of flange should be in accordance with standard, gap of bolt hole should be no more than 120m. Four angles of rectangle duct flange should be designed with screw hole.

3. Strengthening of metal duct

When edge length of rectangle duct is more than 630mm, edge length of insulation duct is more than 800mm and length of pipe section is more than 1250mm, or single-edge level area of low pressure duct is more than 1.2 square meters and single-edge level area of high/middle pressure duct is more than 1.0 square meter, strengthening measures should be conducted.

4. Strengthening of nonmetallic duct

When diameter or edge length of HPVC duct is more than 500mm, the joint section of duct and flange should be equipped with strengthening board and the gap should not be more than 450mm.

5.3 Connecting Highlights of Duct

1. Supporting, hanging and mounting bracket should be made of angle steel. Position of expansion bolt should be correct, firm and reliable. The buried part could not be painted and oil pollution should be eliminated. Gap should be in accordance with regulation below:

1) If duct is installed horizontally, gap should be no more than 4m when diameter or edge length is less than or equal to 400mm, while the gap should be no more than 3m when diameter or edge length is more than 400mm.

2) If duct is installed vertically, gap should be no more than 4m and make sure there is at least 2 fixed points on single straight pipe.

2. Supporting, hanging and mounting bracket could not be installed at air opening, valve, checking door and automatically controlled device, and distance to air opening or plugged tube shall not be less than 200mm.

3. Hanging bracket should not be hung above flange.

4. Thickness of flange gasket should be 3-5mm. Gasket should be flat on flange and inserting to pipe is not allowed. Set up fixed points at proper place for hanging pipe to prevent vibration.

5. Vertical splice seam of duct should be stagger. Make sure there is no vertical seam at the bottom of duct installed horizontally. As for the installation of flexible short duct, keep proper tightness and no distortion.

6. All metal parts (including supporting, hanging and mounting bracket) on pipeline system engineering should be conducted anti-corrosion treatment.

5.4 Installation of Assembly

1. The regulating device of duct should be installed in place where is easy to operate, flexible and reliable.

2. The air port should be installed firmly and air pipe should be connected tightly. Frame should be tightly contact with decorate of building. The appearance should be smooth and flat, and regulation is flexible.

3. If air port is installed horizontally, deviation of levelness is no more than 3/1000. If air port is installed vertically, deviation of perpendicular should be no more than 2/1000.

4. The same air port in same room should be installed at the same height, and put in order.

6. Heat Insulation Engineering

The insulation of refrigerating equipment and pipe is carried out through general insulation method, which binding the equipment and pipe with solid multi-hole insulation material and exploiting proper wet-proof and protection measures, called insulation structure. The form of insulation structure shall be different in light of different insulation materials. This is a traditional insulation method which is adopted very early. Although its insulation performance is general, but it is simply in structure, convenient in construction and cheap in price, so that it is widely used in refrigeration engineering.

6.1 Insulation of Refrigerant Piping

6.1.1 Operational procedure of refrigerant piping insulation

Construction of refrigerant pipe → insulation (excluding connecting section) → test for air sealing
→connecting section insulation

Connecting section: for instance, insulation construction just could be carried out after air tightness test at welding area, opening expending area and flange joint is successful.

6.1.2 Purpose of refrigerant piping insulation

1. During operation, temperature of gas pipe and liquid pipe shall be over-heating or over-cooling extremely. Therefore, it is necessary to carry out insulation; otherwise it shall reduce the performance of unit and burn compressor.
2. Gas pipe temperature is very low during cooling. If insulation is not enough, it shall form dew and cause leakage.
3. Temperature of outlet pipe (gas pipe) is very high (generally 50-100°C) during heating. Touching due to carelessness shall cause hurt, so it is necessary to take insulation measures to avoid getting hurt.

6.1.3 Selection of insulation materials for refrigerant piping

Adopt hole-closed foam insulation materials with level B1 of burning retardant and over 120°C of constant burning performance.

6.1.4 Thickness of insulation layer

1. When outer diameter of copper pipe (d) is less than or equal to 12.7mm, the thickness of insulation layer (δ) shall be above 15mm.

When outer diameter of copper pipe (d) is more than or equal to 15.88mm, the thickness of insulation layer (δ) shall be above 20mm.

2. In hot and wet environment, the above recommended value shall be increased one time.

Note: The outdoor pipeline shall be protected by metal case to proof sunshine, storm and air erosion, and prevent damage of external force or man-made destroy.

6.1.5 Installation and highlights of insulation construction

1. Example of wrong operation: Gas pipe and liquid pipe are carried out insulation together; causing the operation effect of air conditioner is bad.

2. Example of correct operation:

- a. Gas pipe and liquid pipe are carried out heat insulation separately.

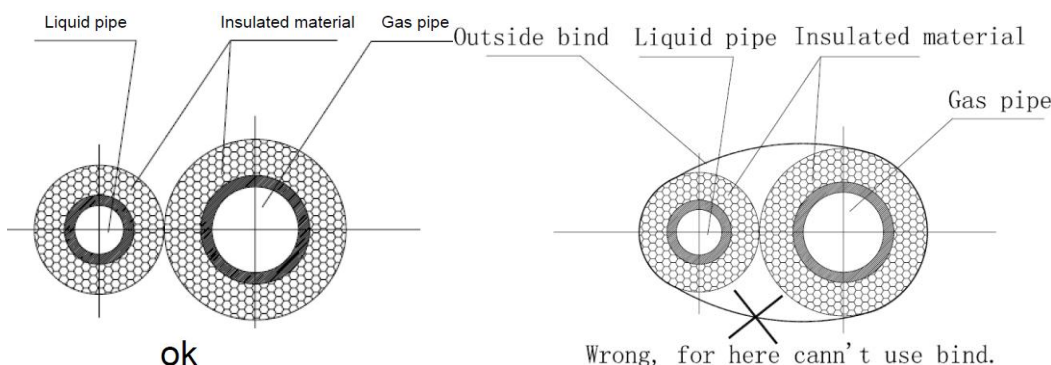

Note: After gas pipe and liquid pipe are carried out heat insulation separately, bind with tape. If it is bound over tightly, the spliced insulation joint shall be damaged.

b. The surrounding of pipe connecting section shall be carried out insulation entirely.

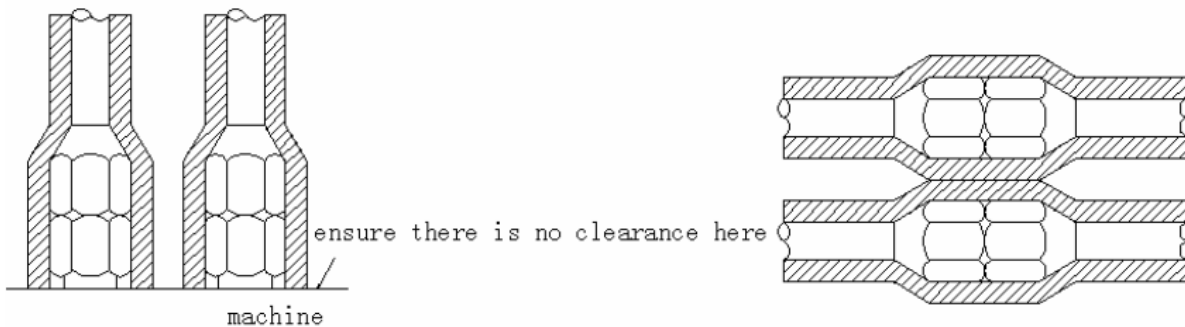

Highlights:

1. No gap in joint of insulation materials.
2. If the joint of insulation materials is linked tardily and tape is bound over tightly, shrinkage and leakage shall be produced easily to create phenomena of dew-drop. The over-tightened tape shall edge out air in material, leading to decrease the insulation effect at this part; meanwhile tape shall be easily age and drop down.
3. In indoor shield space, it is no necessary to bind belting, so as to avoid influencing insulation effect. Correct repairing method for insulation cotton: (see the figure below)

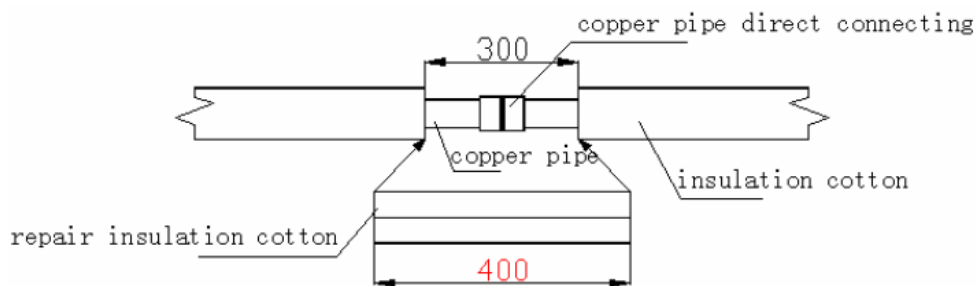

Firstly cut out the material longer than gap, expend the two ends and embed the insulated cotton, at last, paste joint with glue.

Highlights of insulation repairing:

1. Repaired length of insulation (insulation tube with filled gap) shall be 5-10cm longer than the length of gap under natural status.
2. Sliver the cut of insulation to be repaired and cross-section shall be even.
3. Insert gap with insulation for repairing and cross-section shall be pressed tightly.
4. All cross-section and cut need to be pasted with glue.
5. Finally, bind the seam with rubber/plastic tape.
6. Prohibit conducting insulation by using binder fabric in concealed section, so as to avoid influencing insulation effect.

6.2 Insulation of Condensate Water Pipe

6.2.1 Insulation of condensate water pipe

1. Select rubber/plastic tube with burning retardant of rating B1.
2. Thickness of insulation layer is usually above 10mm.
3. The insulation material at water outlet of unit body should be pasted with glue on the unit body, so as to avoid dewing and dripping.
4. Pipe installed in wall shall not be conduct insulation.
5. Use specific glue to paste the seam of insulation material, and then bind with cloth tape. The width of tape shall not be less than 5cm. Make sure it is firm and avoid dewing.

6.3 Insulation of Duct

I. Insulation of duct

1. Insulation of duct parts and equipment should be conducted after confirming that the leakage test and quality of duct is qualified.
2. Usually making use of centrifugal glass cotton, rubber/plastic material or other late-model insulation duct to conduct insulation.
3. Insulation layer should be even and tight. Crack, gap and other defects are not allowed.
4. The supporting, hanging and mounting bracket of duct should be set up to the outside of insulation layer, and insert bed timber between bracket and duct.
5. Thickness of insulation layer
 - 1) As for the inlet and outlet duct installed in room free of air conditioner, the thickness of insulation layer should be above 40mm when adopting centrifugal glass cotton for insulation.
 - 2) As for the inlet and outlet duct installed in room with air conditioner, the thickness of insulation layer should be above 25mm when adopting centrifugal glass cotton for insulation.
 - 3) When adopting rubber/plastic material and other materials, the thickness of insulation layer should become out in accordance with design requirement or calculation.

7. Electrical Engineering

Please refer to “Part 3. Outdoor Units Specification & Performance”.

Highlights of electrical installation

1. Purchased wiring, parts and materials should be in compliance with the local and national regulations.
2. All field wiring construction should be finished by qualified electrician.
3. Air conditioning equipment should be grounded according to the relevant local and national electrical regulations.
4. Current leakage protection switch should be installed (select current leakage breaker in light of the 1.5-2 times of total loading rated current.)
5. When connecting wiring and wire holder, use cable clamp to fix and make sure no exposure.
6. Refrigerant piping system and wiring system of indoor and outdoor unit belongs to the different system.
7. Do not connect the power wire to the terminal of signal wire.
8. When power wire is parallel with signal wire, put wires to their own wire tube and remain proper gap (the current capacity of power wire is: 10A below 300mm, 50A below 500mm).
9. Voltage discrepancy of power wire terminal (side of power transformer) and end voltage (side of unit) should be less than 2%. If its length could not be shortened, thicken the power wire. Voltage discrepancy between phases shall not pass 2% rated value and Current discrepancy between highest and lowest phase should be less than 3% rated value.

Selection of Wiring

1. The selection of wiring area shall in accordance with the requirements below:
 - 1) Voltage lose of wire shall meet the requirement of terminal voltage for normal operation and startup.
 - 2) The wiring current-carrying capacity determined by installed method and environment is not less than the largest current of unit.
 - 3) Wiring shall ensure the stability of movement and heating.
 - 4) The smallest sectional area should satisfy the requirement of mechanical strength.

Sectional area of core to phase line S(mm ²)	Smallest sectional area of PE line (mm ²)
S ≤ 16	S
16 < S ≤ 35	16
S > 35	S/2

When earth protection line (shortly called PE line) is made of material the same as phase line, the smallest sectional area of PE line should be in accordance with the regulation below:

Sectional area of core to phase line S(mm²) Smallest sectional area of PE line (mm²)

Distribution highlights of distribution wiring

1. When distributing wiring, select wirings with different colors for phase line, zero line and protection earth according to relevant regulations.
2. The power wire and control wire of concealed engineering is prohibited to bind together with refrigerant piping. It is necessary to pass through wire tube and be distributed separately, and the gap between control line and power wire should be 500mm at least.
3. When distributing wiring by passing through pipe, the following should be paid attention to:
 - 1) Metal wire tube could be used in indoor and outdoor, but it is not suitable to place with acid - alkali corrosion.
 - 2) Plastic wire tube is generally used in indoor and place with corrosion, but it is not suitable to situation with mechanical damage.
 - 3) The wiring through pipe shall not be in the form with ends jointing. If joint is a must, connection box

should be installed at the corresponding place.

- 4) The wiring with different voltage should not pass through the same wire tube.
- 5) Total sectional area of wiring through wire tube shall not exceed 40% valid area of stuffing tube.
- 6) Fixing point of wire tube support shall follow the standard below:

Nominal diameter of wire tube (mm)	Largest gap between fixed points of wire tube	
	Metal pipe	Plastic pipe
15-20	1.5	1
25-32	2	1.5
40-50	2.5	2

Control System and Installation

Connecting highlights of control line (RS-485 communication)

1. The control line should be shielded wire. Using other wiring shall create signal interference, thus leading to error operation.
2. Single end to shield net of shielded wire should be grounded.
Note: The shield net should be grounded at the wiring terminal of outdoor unit. The inlet and outlet wire net of indoor communication wire should be connected directly and could not be grounded, and form open circuit at the shield net of final indoor unit.
3. Control wire could not be bound together with refrigerant pipeline and power wire. When power wire and control wire is distributed in parallel form, keep gap between them above 300mm so as to preventing signal interference.
4. Control wire could not form closed loop.
5. Control wire has polarity, so be careful when connecting.

8. Commissioning

8.1 Work before Commissioning

8.1.1 Inspection and confirmation before Commissioning

1. Check and confirm that refrigeration pipe line and communication wire with indoor and outdoor unit have been connected to the same refrigeration system. Otherwise, operation troubles shall happen.
2. Power voltage is within $\pm 10\%$ of rated voltage.
3. Check and confirm that the power wire and control wire are correctly connected.
4. Check whether wire controller is properly connected.
5. Before powering on, confirm there is no short circuit to each line.
6. Check whether all units have passed nitrogen pressure-keeping test for 24 hours with R410A: 40kg/cm^2 .
7. Confirm whether the system to Commissioning has been carried out vacuum drying and packed with refrigeration as required.

8.1.2 Preparation before Commissioning

1. Calculating the additional refrigerant quantity for each set of unit according to the actual length of liquid pipe.
2. Keep required refrigerant ready.
3. Keep system plan, system piping diagram and control wiring diagram ready.
4. Record the setting address code on the system plan.
5. Turn on power switches outdoor unit in advance, and keep connected for above 12 hours so that heater heating up refrigerant oil in compressor.
6. Turn on gas pipe stop valve, liquid pipe stop valve, oil balance valve and gas balance valve totally. If the above valves do not be turned on totally, the unit should be damaged.
7. Check whether the power phase sequence of outdoor unit is correct.
8. All dial switches to indoor and outdoor unit have been set according to the Technical Requirement of Product.

Note: The setting of outdoor unit's dial switch should be conducted under power-off, otherwise the unit shall not identify. The following table shows the address and power of outdoor master and slave unit:

ADDRESS dial switch		POWER dial switch	
0	Master unit	0	8HP
1	Salve unit 1	1	10HP
2	Salve unit 2	2	12HP
3	Salve unit 3	3	14HP
≥ 4	Invalid address, system error	4	16HP
/		5	18HP
		≥ 6	Invalid dial switch

8.2 Commissioning of Trial Run

8.2.1 Commissioning for trail run of single unit.

1. Each independent refrigeration system (i.e. each outdoor unit) should be conducted trail operation.
2. Detection details of trail run:
 - 1) As for fan in unit, make sure the rotating route of its impeller is correct and impeller turns around smoothly. No abnormal vibration and noise.
 - 2) Check whether there is abnormal noise during operation of refrigerant system and compressor.
 - 3) Check outdoor unit whether it can detect each indoor unit.
 - 4) Check whether drainage is smooth and its lift pump can be in motion.

- 5) Check whether microcomputer controller can be in motion normally and whether any trouble appears.
- 6) Check whether operating current is within the allowed range.
- 7) Check whether each operating parameter is within the range permitted by the equipment.

Note: When conducting trial run, separately test cooling mode and heating mode to judge the stability and reliability of system.

8.2.2 Commissioning for the trial run of the paralleled system

1. Check and confirm that operation of single unit is normal through trial operation. After confirm it is normal, conduct operation of the whole system, i.e., Commissioning of MDV system.
2. Commissioning is carried out according to the Technical Requirement of Product. When Commissioning, analyze and record operation status so as to understand the operation status of the whole system for convenient maintenance and examination.
3. After finishing Commissioning, fill out Commissioning report in detail.

The commissioning report form is shown as follows:

Commissioning Report for Midea VRF System

Date: ddmmyy

Item name:	
Address:	Tel:
Supplier:	Delivery date: dd mm yy
Installation section:	Principal:
Commissioning section:	Principal:
Remark: recharged refrigeration quantity to system: kg	
Name of refrigerant:	(R22, R407C, R410A)

Installing section:
(seal)

Commissioning name:
(seal)

Signature:

Signature:

Date: ____dd____mm____yy

Date: ____dd____mm____yy

Test Data for Test Run of _____ System

Model of outdoor unit	Production series no.

Operation data of outdoor unit (Cooling)

Unit	No.1	No.2	No.3
Run Voltage V			
Total current of run A			
Operation current of compressor A			
High-pressure pressure Kg/cm ²			
Low-pressure pressure Kg/cm ²			
Inlet air temperature °C			
Outlet air temperature °C			

Operation data of indoor unit

No.	Position	Model	Bar code of indoor unit	Inlet air temperature °C	Outlet air temperature °C
1					
2					
3					
4					
5					
6					
7					
8					
9					
10					
11					
12					
13					
14					
15					
16					

System parameter

SW2:

(CHECK)——Used to query outdoor unit data. Check point sequence and corresponding actuality is as follows:

No.	Display code	Display content	Note	No.	Display code	Display content	Remark
1	0--	Address of outdoor unit	0,1,2,3	17	16--	Tp saturation temp	Actual value+30
2	1--	Capacity of outdoor unit	8,10,12,14,16,18	18	17--	Current of inverter compressor	Actual value
3	2--	Qty.of Modular outdoor unit	Setting on main unit	19	18--	Current of fixed compressor	Actual value
4.	3--	Setting of indoor units	Setting on main unit	20	19--	Opening angle of EXV-1	Display value x8
5	4--	Total cap. of outdoor unit	Setting on main unit	21	20--	Opening angle of EXV-2	Display value x8
6	5--	Total requirement of indoor unit	Available for main unit	22	21--	High pressure	Actual value x10
7	6--	Total requirement of main unit corrected capacity	Available for main unit	23	22--	Qty. of indoor unit	If no, display 00
8	7--	Operation mode	0,2,3,4	24	23--	Qty. of operating indoor units	
9	8--	This outdoor units actual operation capacity	Capacity requirement	25	24--	Priority mode	
10	9--	Speed of fan 1	Actual value	26	25--	Noise control mode	0,1,2,3
11	10--	Speed of fan 2	Actual value	27	26--	Reserve	
12	11--	T2/T2B average Temp	Actual value	28	27--	DC Voltage	
13	12--	T3 Pipe	Actual value	29	28--	Reserve	
14	13--	T4 ambient temp	Actual value	30	----	The last error or protection code	Without error/protection display8.8.8
15	14--	Discharge Temp. of Inverter Compressor	Actual value	31	----	--	Check end
16	15--	Discharge Temp. of fixed compressor	Actual value				

Note: When operation of system lasts 1 hour and stays stability, press checkup button on PCB of outdoor master unit, query one by one and fill out the above table according to facts.

Description of display:

Operation mode: 0---Turn off; 2---Cooling; 3---Heating; 4---Constraint cooling

Fan speed:0—OFF; 1~15—Speed increasing sequentially; 15—is the max. fan level.

PMV opening angle: pulse count = display value x 8.

Noise control mode: 0—Night silent mode;1—Silent mode; 2—super silent mode; 3—no priority

Priority mode:0—heating priority mode;1—cooling priority mode; 2—opening the priority mode; 3—response the heating mode only; 4—response the cooling mode only.

SW1: Constrain cool button

SW2: Query switch

ENC1: Outdoor units address setting switch. ENC2: Outdoor units capacity setting switch. ENC3: Indoor units Qty. setting switch.

ENC4: Network address setting switch.

Normal display: when in standby mode, it indicates number of indoor units, when running, it indicates output percentage value of compressor.

Part 5 Troubleshooting

1. PCB ports instructions	2
2. PCB parts instructions	4
3. Error code table	8
4. Troubleshooting.....	10

1. PCB ports instructions

Main board used on 8/10/14/16/18HP outdoor unit

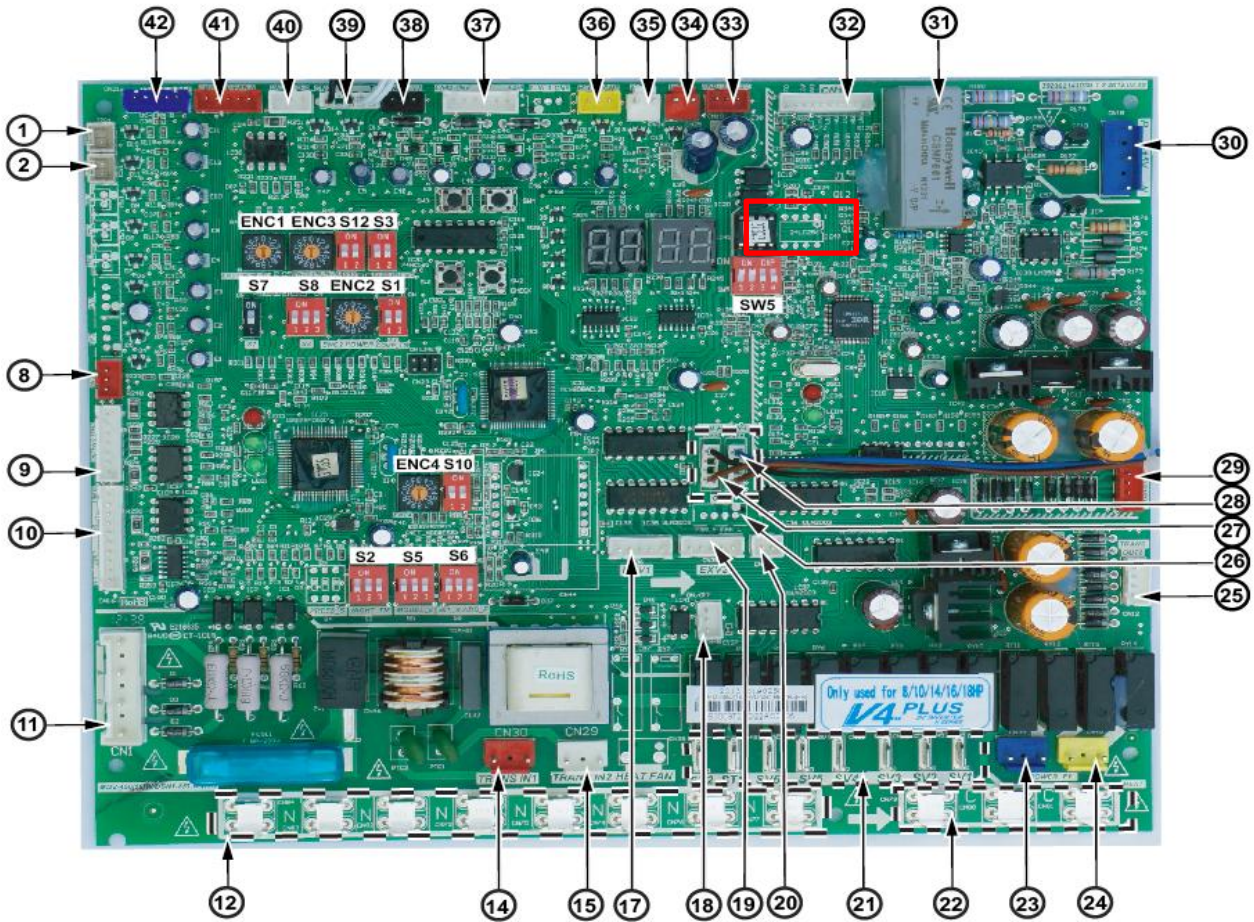

Main board used on the 12HP outdoor unit

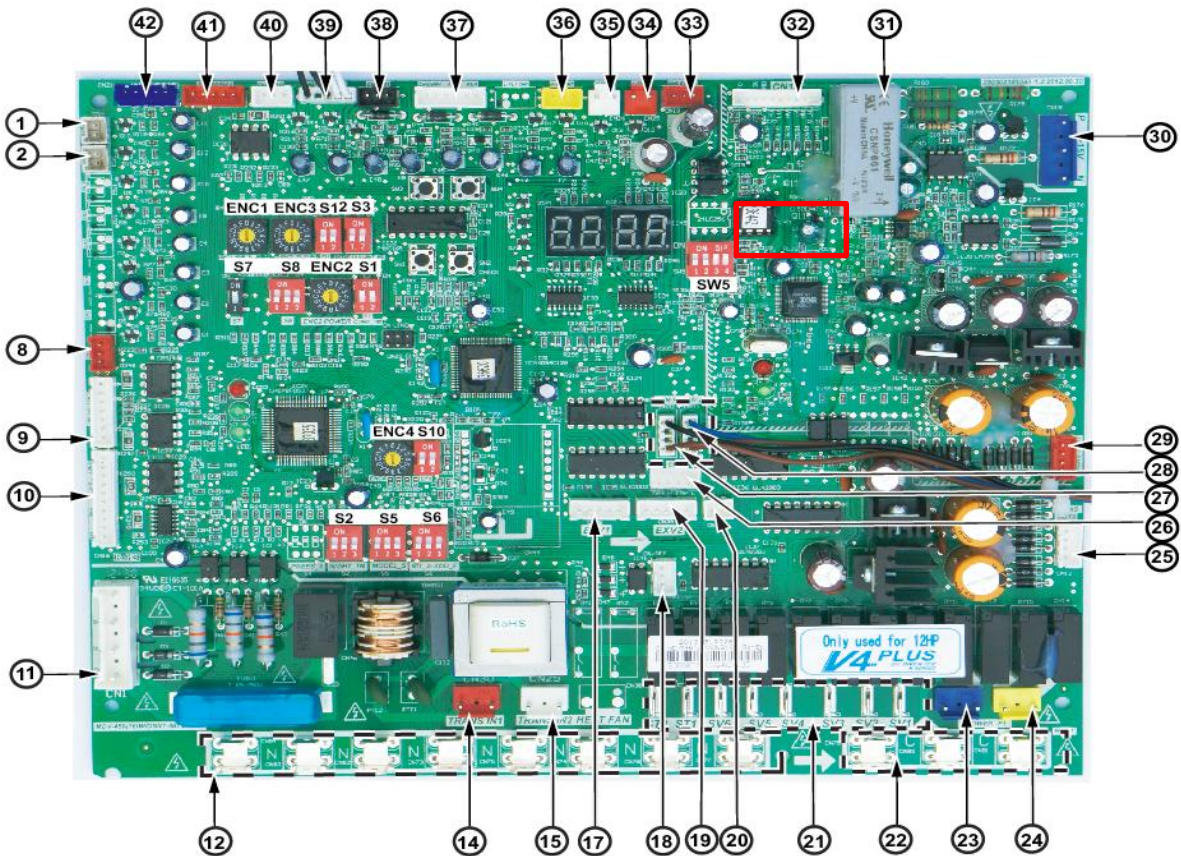

PCB ports instruction

No.	Content	Port voltage
1 CN10	Discharge temperature sensor port of the inverter compressor	DC 0~5V (in dynamic change)
2 CN11	Discharge temperature sensor port of the fixed (8-10HP:inverter)compressor	DC 0~5V (in dynamic change)
8 CN2	Power supply port in the mid-adapted panel	DC 0~5V
9 CN22	Reserved	-
10	Wiring port for communication between indoor and outdoor units, indoor unit network, outdoor unit network and network accounting	DC 2.5~2.7V
11	Phase inspection port	380V
12	Null line port	220V
14 CN30	Power input of the NO.1 transformer	220V
15 CN29	Power input of the NO.2 transformer	220V
17 CN36	EXV 1 driving port	The first pin on the left: DC 12V
18 CN45	Reserved	-
19 CN35	EXV 2 driving port	The first pin on the left: DC 12V
20 CN37	Power supply port of 12V DC	12V
21 CN51	Loading output terminal	220V
22 CN79	Loading output terminal	220V
23 CN39	Loading output terminal	220V
24 CN40	Loading output terminal	220V
25 CN12	Power output of the NO.1 transformer	Yellow-Yellow: AC 9V
26 CN17	Control port of AC fan	DC 0~12V
27 CN32	High-fan control port of AC fan	DC 0~12V
28 CN33	Low-fan control port of AC fan	DC 0~12V
29 CN15	Power output of the NO.2 transformer	Yellow-Yellow: AC 14.5V
30 CN18	Port for inverter module voltage inspection	DC 540V,+15V,N
31	Mutual inductor for DC main lead current	In dynamic change
32 CN13	Activation port of inverter module	The third pin on the left: DC 3.3V
33 CN19	Power supply connected port of the main control panel	GND +5V +12V
34 CN25	ON/OFF single input for system low pressure inspection	DC 0~5V (in dynamic change)
35 CN26	ON/OFF single input for system high pressure inspection	DC 0~5V (in dynamic change)
36 CN7	Input port for system high pressure inspection	DC 0~5V (in dynamic change)
37 CN43	Current inspection port of the inverter(fixed) compressors	AC 0~7.8V (in dynamic change)
38 CN28	Reserved	-
39 CN27	Inspection port for outdoor ambient temperature and condenser coil	DC 0~5V (in dynamic change)
40 CN24	Communication ports among outdoor units	DC 2.5~2.7V
41 CN20	Control port of DC fan A	The first pin on the left: DC 5V
42 CN21	Control port of DC fan B(Only for DC+DC condenser fan type)	The first pin on the left: DC 5V

Note:

shows the only difference between two boards.



2. PCB parts instructions

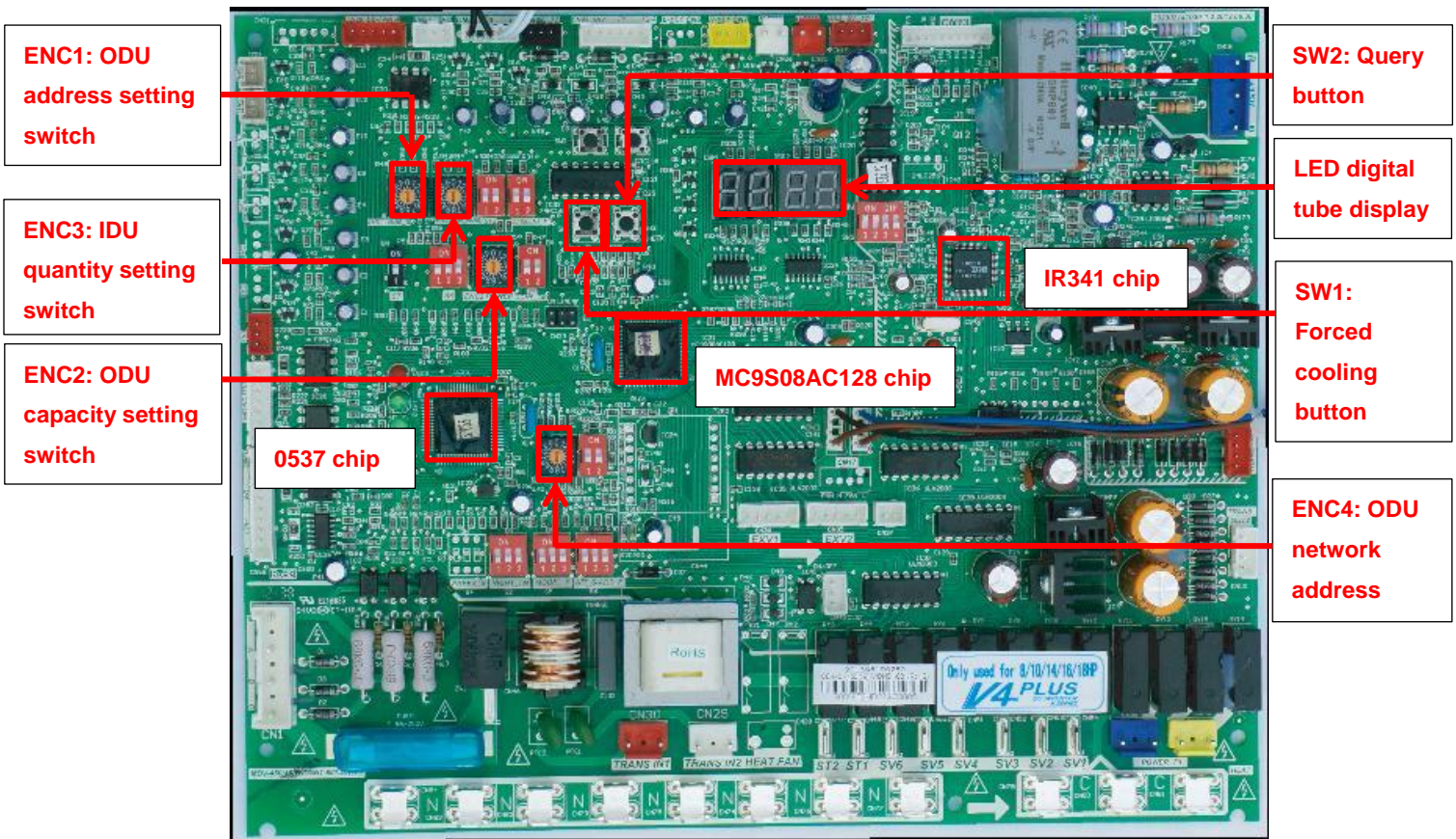

2.1 SW2 query instructions

No.	Normal code	Content	Note
1	0--	Address of ODU	0,1,2,3
2	1--	Capacity of this ODU	8,10,12,14,16,18
3	2--	Quantity of ODU	Only effective for master unit
4	3--	Setting of indoor units quantity	Only effective for master unit
5	4--	Total capacity of ODU	Capacity requirements
6	5--	Total requirement of indoor unit capacity	Only effective for master unit
7	6--	Total requirement of main unit corrected capacity	Only effective for master unit
8	7--	Operation mode	0,2,3,4
9	8--	This outdoor units actual operation capacity	Capacity requirements
10	9--	Speed of fan 1	
11	10--	Speed of fan 2	
12	11--	T2/T2B average temperature	Actual value
13	12--	T3 Pipe	Actual value
14	13--	T4 ambient temp	Actual value
15	14--	Discharge temperature of inverter compressor	Actual value
16	15--	Discharge temperature of fixed compressor	Actual value
17	16--	Tp saturation temperature	Actual value+30
18	17--	Current of inverter compressor	Actual value
19	18--	Current of fixed compressor	Actual value
20	19--	Opening angle of EXV-1	Actual value ÷8
21	20--	Opening angle of EXV-2	Actual value ÷8
22	21--	High pressure	Actual value×10MPa
23	22--	Quantity of indoor unit	If no, display 00
24	23--	Quantity of operating indoor units	Actual value
25	24--	Priority mode	0,1,2,3,4
26	25--	Noise control mode	0,1,2,3
27	26--	Reserved	
28	27--	DC voltage	
29	28--	Reserved	
30	----	The last error or protection code	Without error/protection display8.8.8
31	----	----	Check end

2.2 Dial codes definition

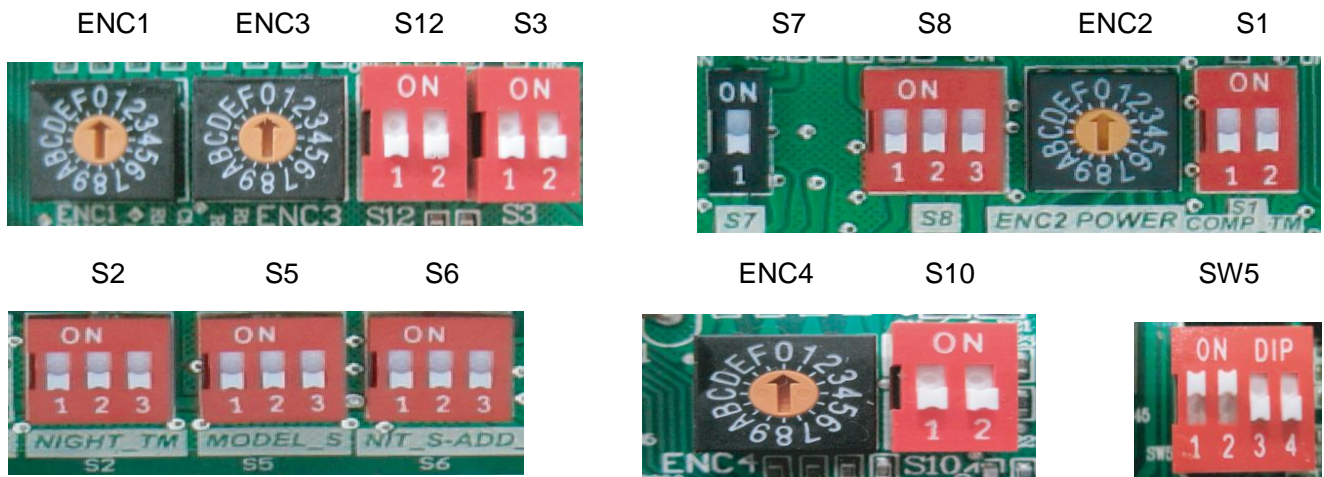

ENC1 definition

	Outdoor unit address setting switch Effective to 0-3 0 stand for main unit 1-3 stand for slave unit
--	--------------------------------------------------------------------------------------------------------------

ENC2 definition

	Outdoor units capacity setting switch Effective to 0-5 0-5 stand for 8HP-18HP
--	-------------------------------------------------------------------------------------

ENC4 definition

	Network address setting switch Effective to 0-7
--	----------------------------------------------------

SW5 definition

	12HP outdoor unit setting
	8/10/14/16/18HP outdoor unit setting

S1 definition

	Starting time is set about 5 minutes
	Starting time is set about 12 minutes (Default the Factory Set)

S2 definition

	Night time selection is 6h/10h (Default the Factory Set)
	Night time selection is 6h/12h
	Night time selection is 8h/10h
	Night time selection is 8h/12h

S3 definition

	Night silent mode (Default the Factory Set)
	Silent mode
	Super silent mode
	None silent mode

S5 definition

	Heating priority mode (Default the Factory Set)
	Cooling priority mode
	VIP priority or vote priority
	Respond the heating mode only
	Respond the cooling mode only

S6 definition

	Automatic search address
	Nonautomatic search address. (The communication way of the original indoor units) (Default the Factory Set)
	Clean the indoor unit address (Effective to automatic searching new indoor units)

S7 definition

	Without setting the numbers of indoor units (Default the Factory Set)
	Need to set the numbers of indoor units

S10 definition

	Reserve
--	---------

ENC3+S12: Indoor unit quantity setting

		The quantity of indoor unit is 0-15 0~9 on ENC3 refer to 0~9 indoor units; A~F on ENC3 refer to 10~15 indoor units.
		The quantity of indoor unit is 16-31 0~9 on ENC3 refer to 16~25 indoor units; A~F on ENC3 refer to 26~31 indoor units.
		The quantity of indoor unit is 32-47 0~9 on ENC3 refer to 32~41 indoor units; A~F on ENC3 refer to 42~47 indoor units.
		The quantity of indoor unit is 48-63 0~9 on ENC3 refer to 48~57 indoor units; A~F on ENC3 refer to 58~63 indoor units.

2.3 LED on PCB instructions

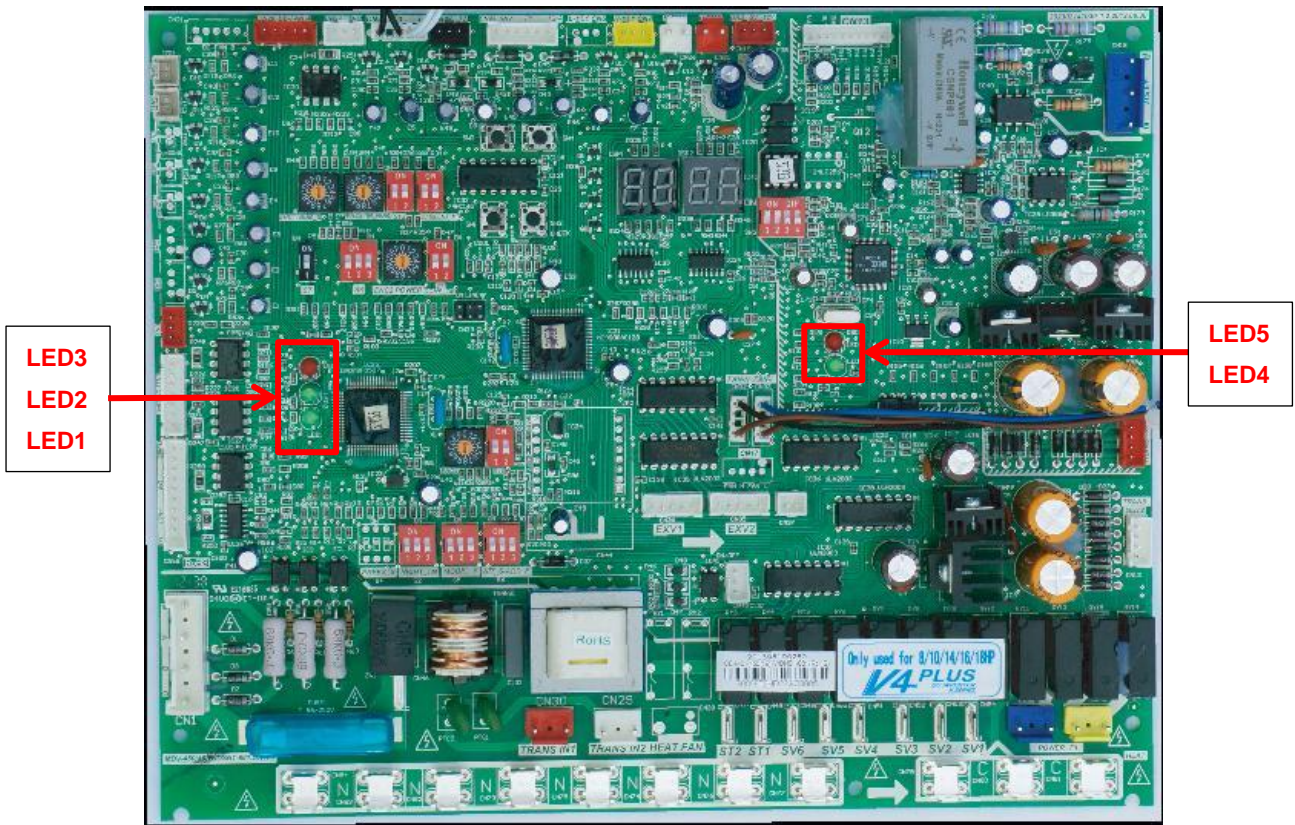

- LED1:** Power supply indicator lamp. The lamp will be on if the power supply is normal.
- LED2:** Running indicator lamp. The lamp will be on if the system running is normal.
- LED3:** Malfunction indicator lamp of network centralized control chip. The lamp will flash in three-phase phase sequence protection.
- LED4:** Running indicator lamp of inverter module. The lamp will be on if the compressor is running.
- LED5:** Malfunction indicator lamp of inverter module. The lamp will flash if the inverter module is faulty and the error code will display on digital tube.

3. Error code table

Code	Content	Note
E0	Communication error between outdoor units	Only slave unit displays
E1	Phase sequence error	
E2	Indoor units and master unit communication error	The master outdoor unit can't detect the indoor units last for 2 minutes
E3	Reserved	
E4	Outdoor ambient temperature sensor error	
E5	Low-voltage power error	
E6	Reserved	
E7	Discharge temperature sensor error	
E8	Outdoor unit address is wrong	
E9	EEPROM is not matched	
H0	Communication malfunction between IR341 and MC9S08AC128	
H1	Communication malfunction between 0537 and MC9S08AC128	
H2	Outdoor unit quantities decreasing error	Only master unit displays
H3	Outdoor unit quantities increasing error	Only master unit displays
H4	3 times P6 protection caused in 60 minutes	Not recoverable until re-power on
H5	3 times P2 protection caused in 60 minutes	Not recoverable until re-power on
H6	3 times P4 protection caused in 100 minutes	Not recoverable until re-power on
H7	Indoor unit quantities decreasing malfunction over 3 minutes	Indoor unit lost for over 3 minutes; not recoverable, until the unit qty. recover
H8	Pressure sensor error	Air discharging pressure $P_c \leq 0.3\text{MPa}$
H9	3 times P9 protection in 60 minutes	Not recoverable until re-power on
XHd	No. X slave unit error	
HC	Outdoor unit capacity setting error	
P0	The sensor protection on the top of inverter compressor.	
P1	High pressure protection	
P2	Low pressure protection	After 3 times P2 protection in 60 minutes will report H5
P3	Inverter compressor over current protection	
P4	Discharge temperature sensor protection	After 3 times P4 protection in 100 minutes will report H6
P5	Pipe temperature sensor protection	
P7	Fixed compressor current protection	
P8	Reserved	
P9	DC Fan motor module protection	After 3 times P9 protection in 60 minutes will report H9
L0	DC Inverter compressor Module error	
L1	DC generatrix low voltage protection	
L2	DC generatrix high voltage protection	
L3	Reserved	
L4	MCE malfunction/simultaneously/cycle loop	

L5	Zero speed protection	
L6	Reserved	
L7	Wrong phase protection	
L8	Speed difference >15Hz protection between the front and the back clock	
L9	Speed difference >15Hz protection between the real and the setting speed	
dF	Defrosting (DSP1:dF, DSP2:operating frequency)	
d0	Defrosting (DSP1:d0, DSP2:operating frequency)	

4. Troubleshooting

4.1 E0: Communication error between outdoor units (Only display on faulty slave unit, all the ODU in standby)

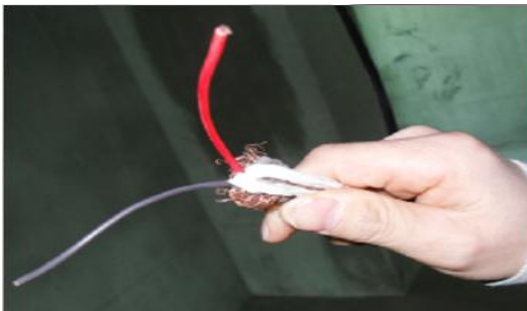
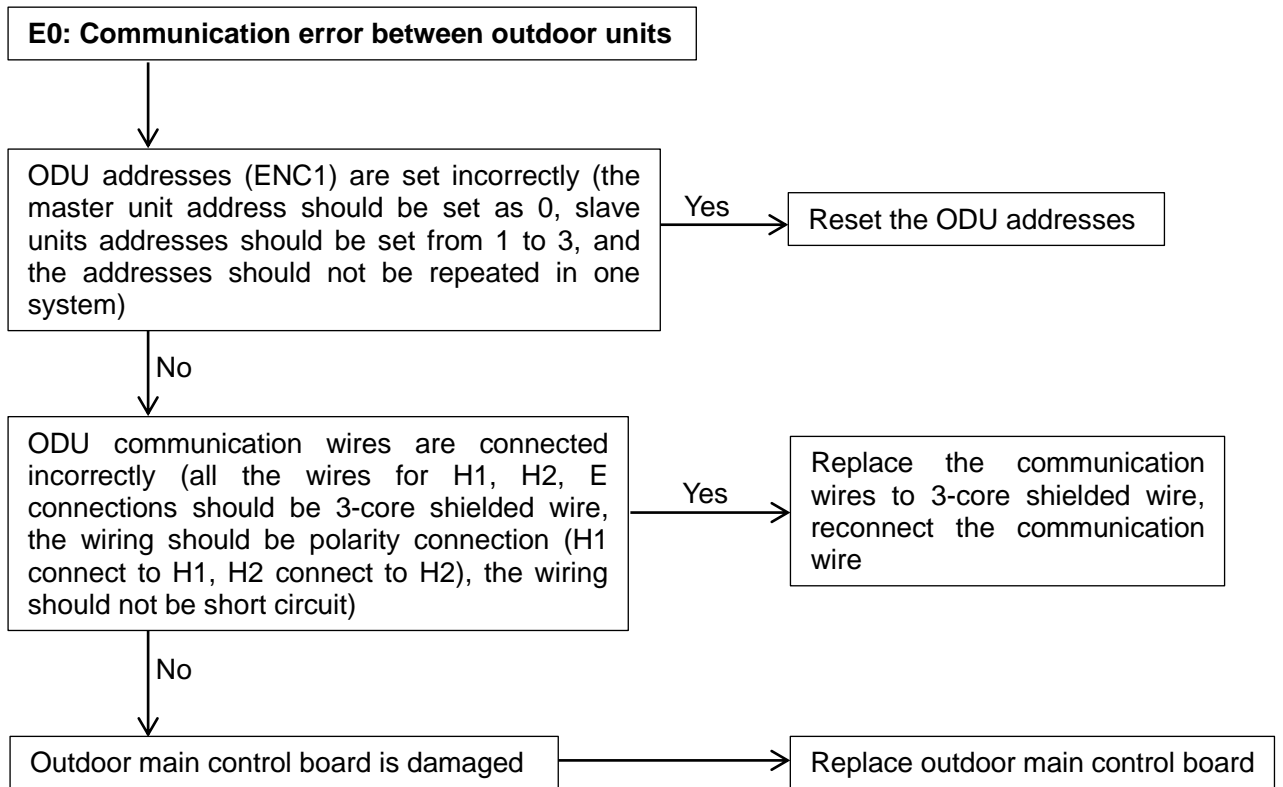

2-core shielded wire (✗)

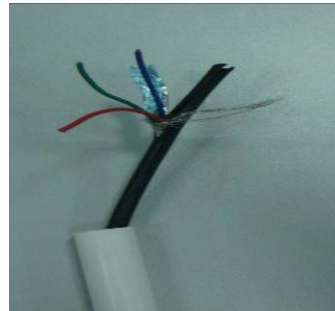

3-core shielded wire (✓)

4.2 E1: Phase sequence error (Display on faulty unit, all the ODU in standby)

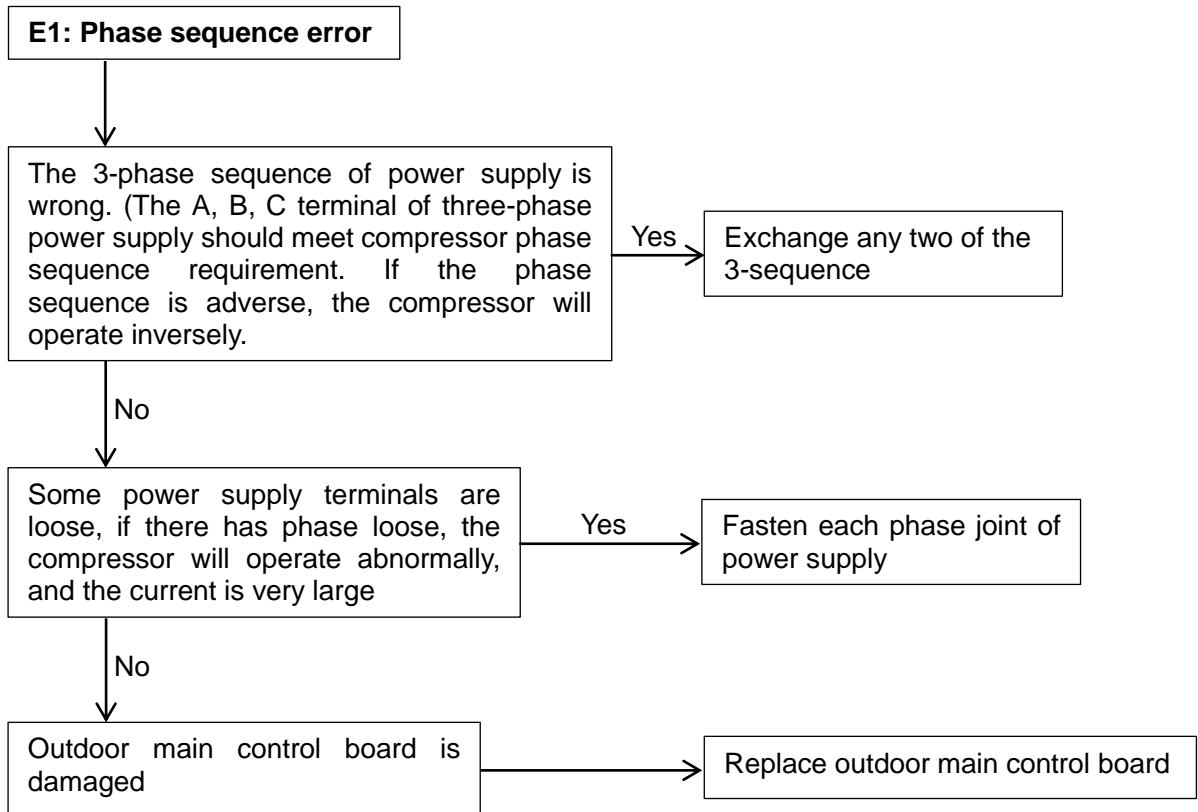

4.3 E2: Indoor units and master unit communication error (Only display on master unit, all the ODU in standby)

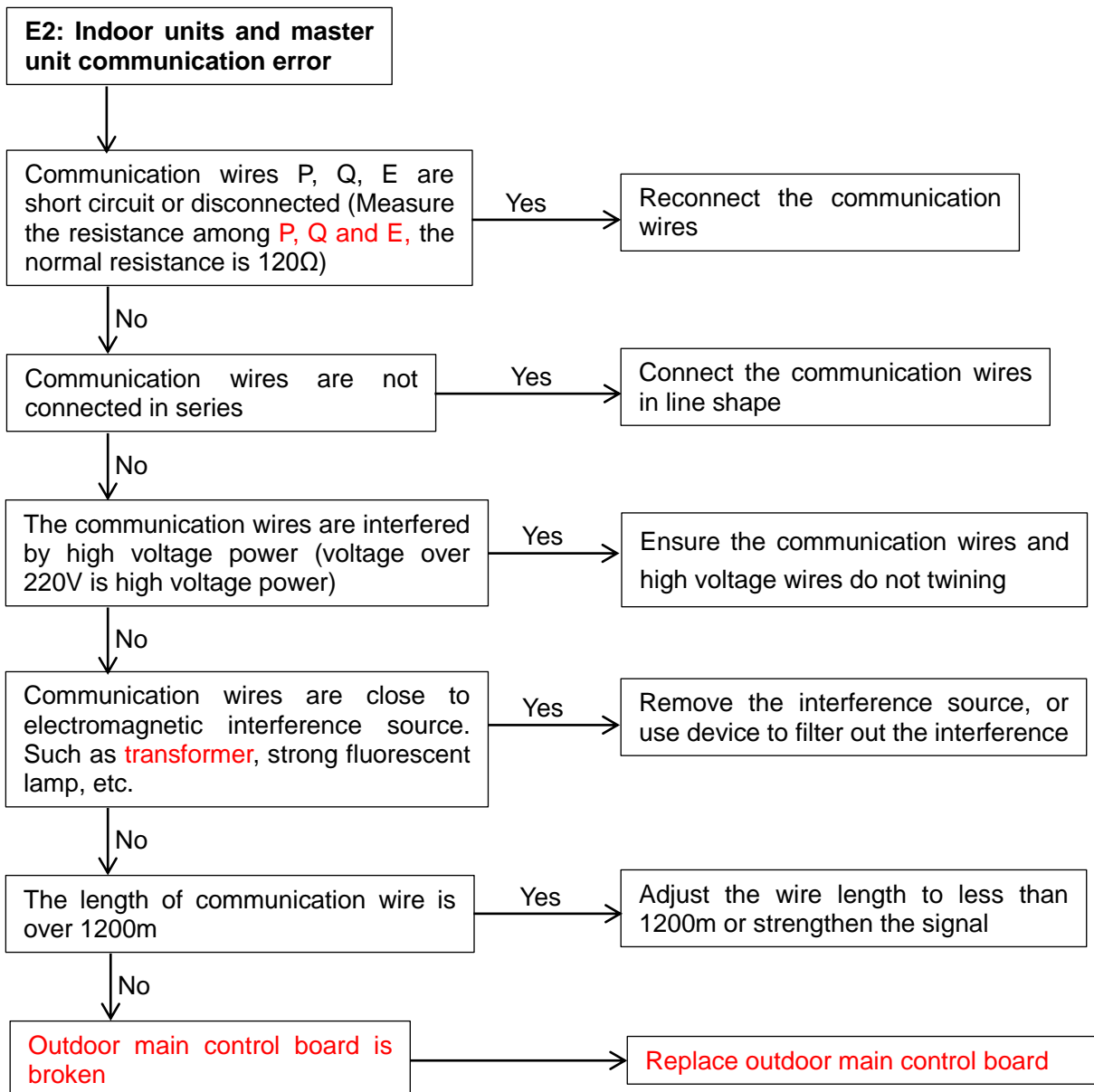

Note:

1. Press the manual button on display board of indoor unit for 5 seconds, the communication address code of indoor unit will display;

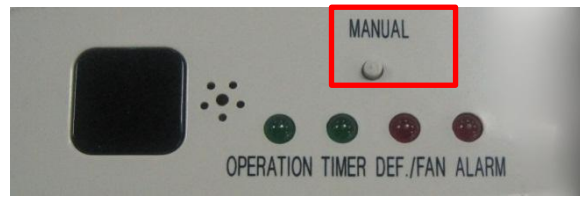

Codes are as follows:

Indicator light	Running	Timer	Fan/defend cold fan	Warning
Code	8	4	2	1

Buzzer	Communication address	Four LED display
Not warning	00---15	Normally on
Not warning	16---31	Flash
Warning	32---47	Normally on
Warning	48---63	Flash

For example:

Press the manual button for 5 seconds:

- If the “Operation”, “Timer” and “DEF./FAN” lights are normally on and the buzzer is not warning, that means the address code is 14=(8+4+2)
- If the four LED lights are flash and the buzzer isn’t warning, the address code should plus 16, that means the address code is 30=16+ (8+4+2)
- If the “Operation”, “Timer” and “DEF./FAN” lights are normally on and the buzzer is warning, that means the address code is 46=32+(8+4+2)
- If the four LED lights are flash and the buzzer is warning, that means the address code is 62=48+ (8+4+2)

2. Press the manual button on display board of indoor unit for 10 seconds, the capacity code of indoor unit will display;

Dial code	Capacity (x100W)	HP
0	22	0.8
1	28	1.0
2	36	1.2
3	45	1.6
4	56	2.0
5	71	2.5
6	80	3.0
7	90	3.2
8	112	4.0
9	140	5.0
A	160	6.0
B	160	6.0
C	160	6.0
D	160	6.0
E	160	6.0
F	160	6.0

For example

Pressing continued the manual button for 10 seconds:

- If all the LED lights turn off, that means the capacity code is 0 and the capacity of indoor units is $22 \times 100\text{W}$ (0.8HP);
- If the “Timer” and “Alarm” lights are normally on, that means the capacity code is $5=(4+1)$ and the capacity of indoor unit is $71 \times 100\text{W}$ (2.5HP);
- If the “Operation” and “Alarm” lights are normally on, that means the capacity code is $9=(8+1)$ and the capacity of indoor unit is $140 \times 100\text{W}$ (5.0HP);
- If all the LED lights turn on, that means the capacity code is $F=(8+4+2+1)$ and the capacity of indoor unit is $160 \times 100\text{W}$ (6.0HP).

The above basic principle just applies to single PCB, if the indoor unit has more than one PCB, or one PCB can achieve a virtual multi blocks function, you must use the basic principle to Calculate the achievable capacity of single PCB at first, then add all the value as the capacity of the indoor unit .

For example

- The high static pressure duct have capacity of 20kW、25kW、28kW and larger capacity of 40kW、45kW、56kW.
- The “Operation” light is normally on, that means the capacity code is 8 and the achievable capacity of single PCB is $112 \times 100\text{W}$ (4.0HP), then add the value of two PCB, so the capacity of indoor unit is $200 \times 100\text{W}$ (8.0HP);
- The “Operation” and “Alarm” lights are normally on, that means the capacity code is $9=(8+1)$ and the achievable capacity of single PCB is $140 \times 100\text{W}$ (5.0HP), then add the value of two PCB, so the capacity of indoor unit is $280 \times 100\text{W}$ (10HP);
- The “Operation” light is normally on, that means the capacity code is 8 and the achievable capacity of single PCB is $112 \times 100\text{W}$ (4.0HP), then add the value of four PCB, so the capacity of indoor unit is $450 \times 100\text{W}$ (16HP);
- The “Operation” and “Alarm” lights are normally on, that means the capacity code is $9=(8+1)$ and the achievable capacity of single PCB is $140 \times 100\text{W}$ (5.0HP), then add the value of four PCB, so the capacity of indoor unit is $560 \times 100\text{W}$ (20HP).

3. If the signal is weak, connect a 120Ω resistor between P and Q of the farthest indoor unit, or connect a 0.5-1.5uF capacitor between P and Q of outdoor unit. Installation refers to the following picture:

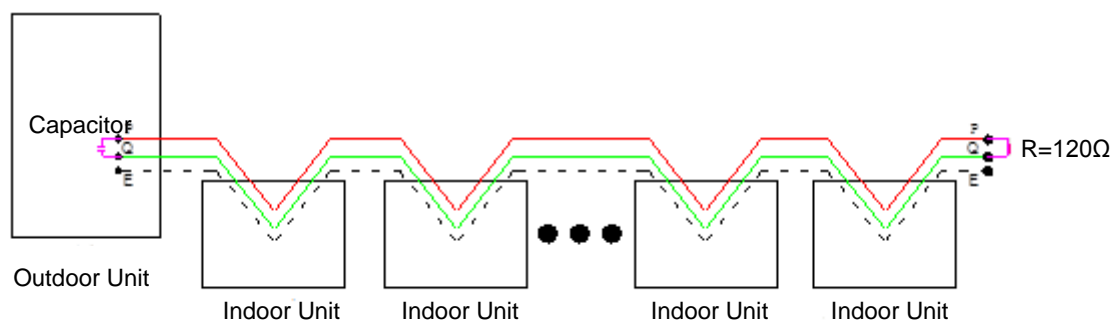

Note:

Communication wires should be shield wire and indoor units should be connected in series.

4.4 E4: Temperature sensor (ambient temperature sensor T4, pipe temperature sensor T3 and discharge temperature sensor T7C1/T7C2/T7C3) error

The error only display on faulty unit, all the ODU will be standby.

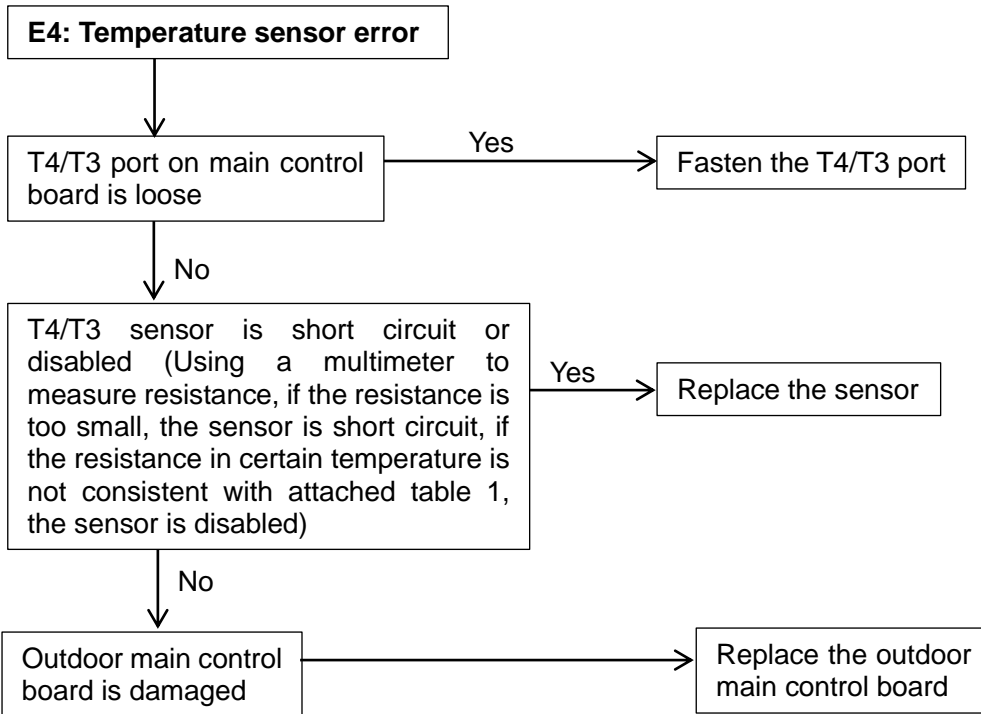

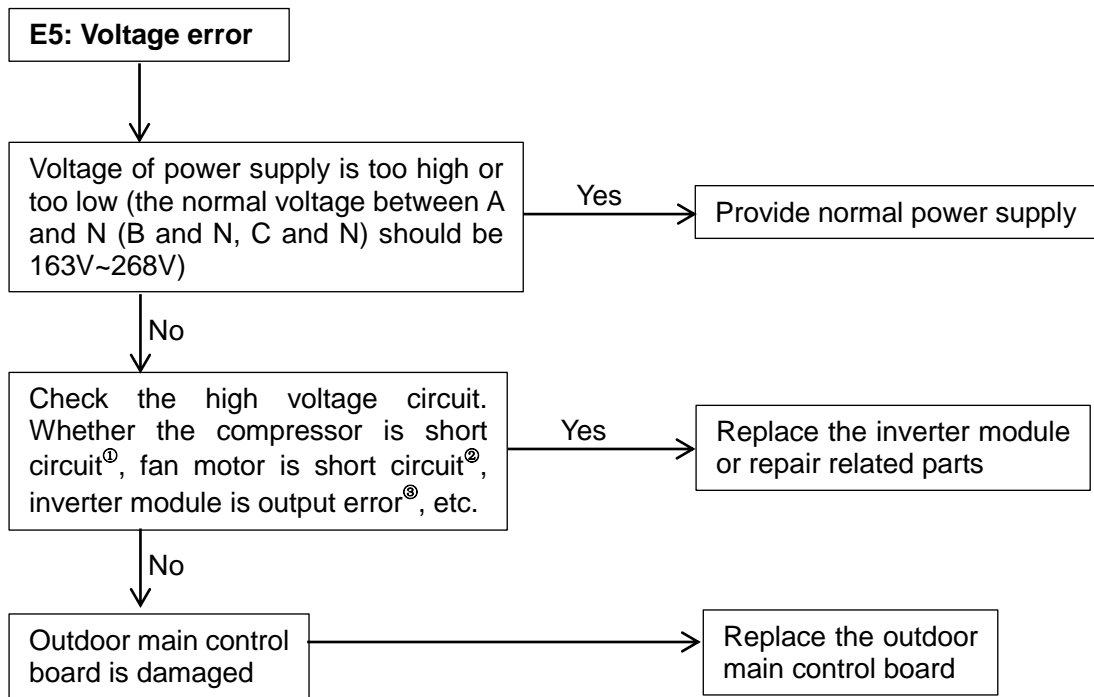
4.5 E5: Voltage error (Display on faulty unit, others in standby)**Note:****1. How to check whether the compressor is short circuit^①:**

The normal resistance value of inverter compressor among U V W is 0.7~1.5Ω, and infinity to earth. If the resistance value is out of the range, the compressor is abnormal.

2. How to check whether the fan motor is short circuit^②:

The normal value of DC fan motor coil among U V W is less than 10Ω, and the value of AC fan motor coil is from a few ohm to hundreds of ohm for different fan motor model. If the measured value is 0Ω, the fan motor is short circuit.

3. How to check whether the inverter module is output error^③:

Dial the multimeter to diode file, black pen on P and red pen respectively on U,V,W, if the multimeter displays 0.4~0.7 V, it is normal; Red pen on N, black pen respectively on U,V,W, if the multimeter displays 0.4~0.7 V, it is normal. Satisfying the above two conditions at the same time indicates that the inverter module has no problem.

4.6 E8: Outdoor unit address is wrong (Only display on faulty slave unit, all the ODU in standby)

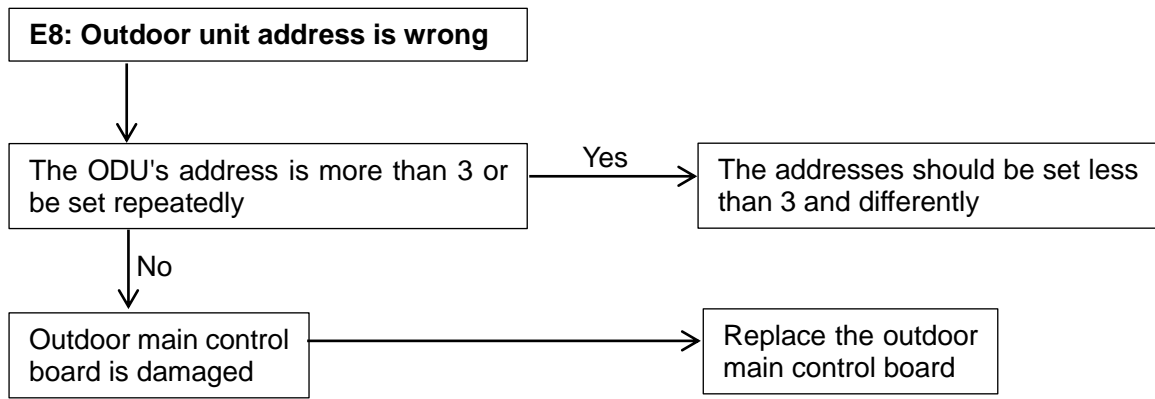

4.7 E9: EEPROM is not matched (Display on faulty unit, all the ODU in standby)

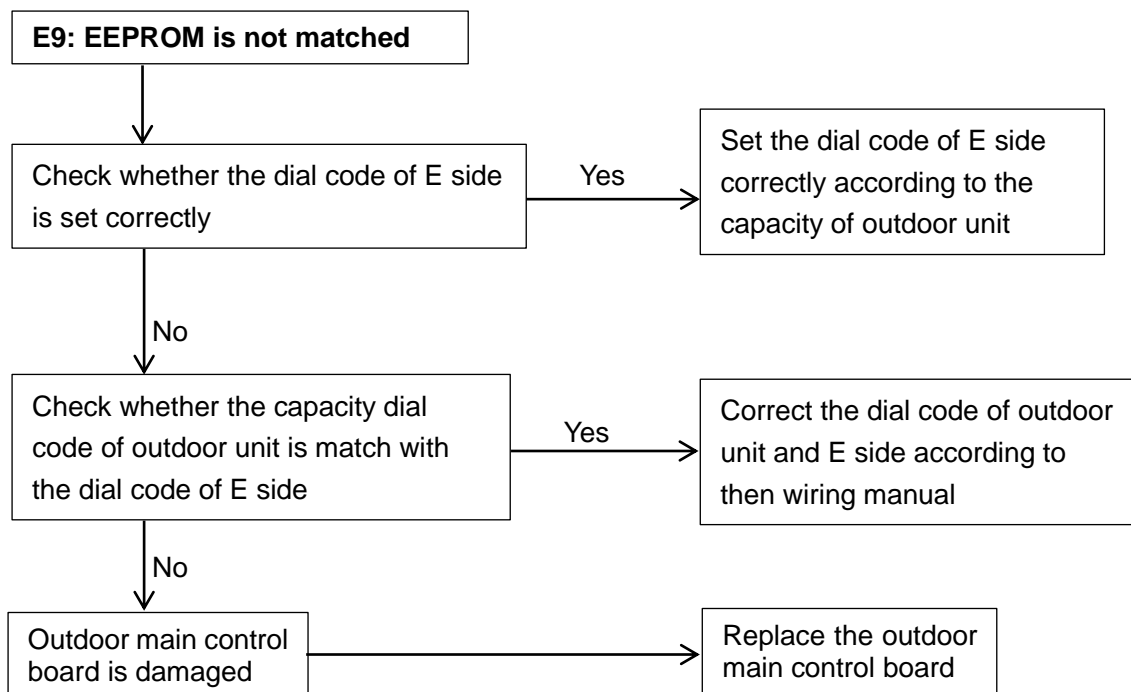

4.8 H0/H1

H0: IR341 and MC9S08AC128 communication error (Display on faulty unit, all the ODU in standby)

H1: 0537 and MC9S08AC128 communication error (Display on faulty unit, all the ODU in standby)

IR341 chip: IR 341chip is used for inverter compressor drive.

0537 chip: 0537chip is used for control the communication between indoor unit and outdoor unit, and the communication between outdoors

MC9S08AC128 chip: MC9S08AC128 chip is the main chip, it used for the whole system control.

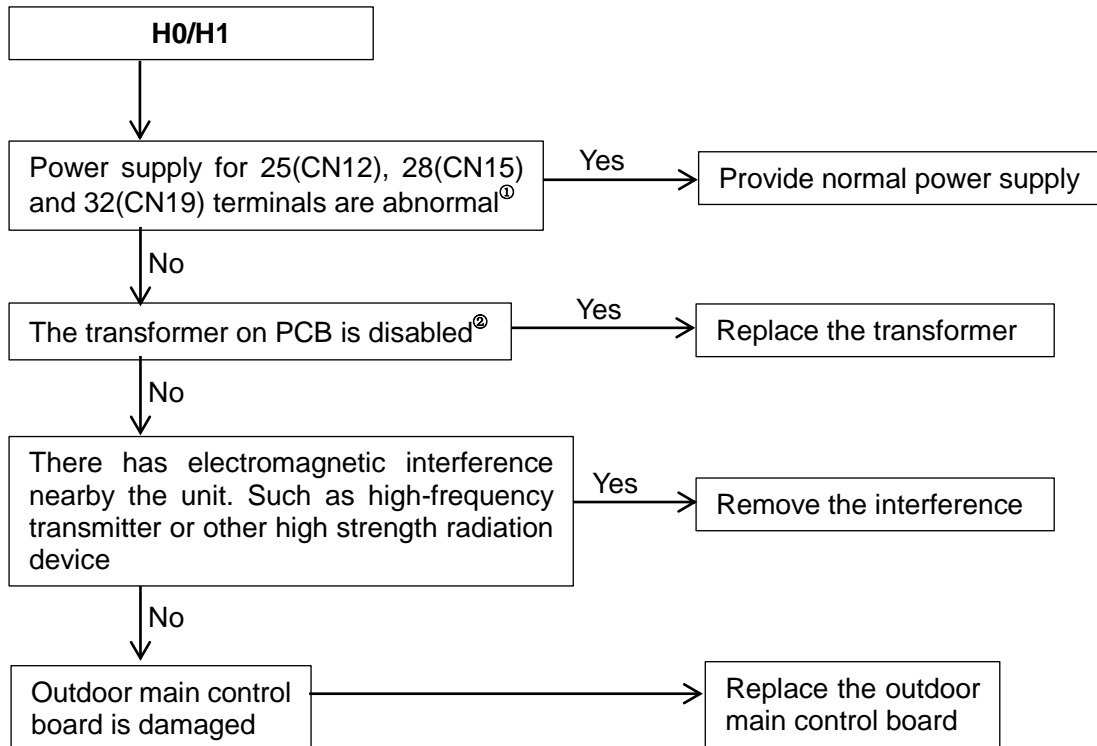

Note:

1. How to check whether power supply for 25(CN12), 28(CN15) and 32(CN19) terminals are abnormal^①

The voltage input for 25(CN12) and 28(CN15) terminals are both 220V, the voltage input between “GND” and “+5V” terminals of 32(CN19) port is 5V, and between “GND” and “+12V” terminals of 32(CN19) port is 12V.

2. How to check whether the transformer on PCB is disabled^②

The voltage input for 25(CN12) and 28(CN15) terminals are both 220V, the voltage output of 25(CN12) terminal is AC9V (yellow-yellow) and AC13.5V (brown-brown); the voltage output of 28(CN15) terminal is AC14.5V (yellow-yellow) and AC 14.5V (blue-blue). If the voltage is out of the range, the transformer is disabled.

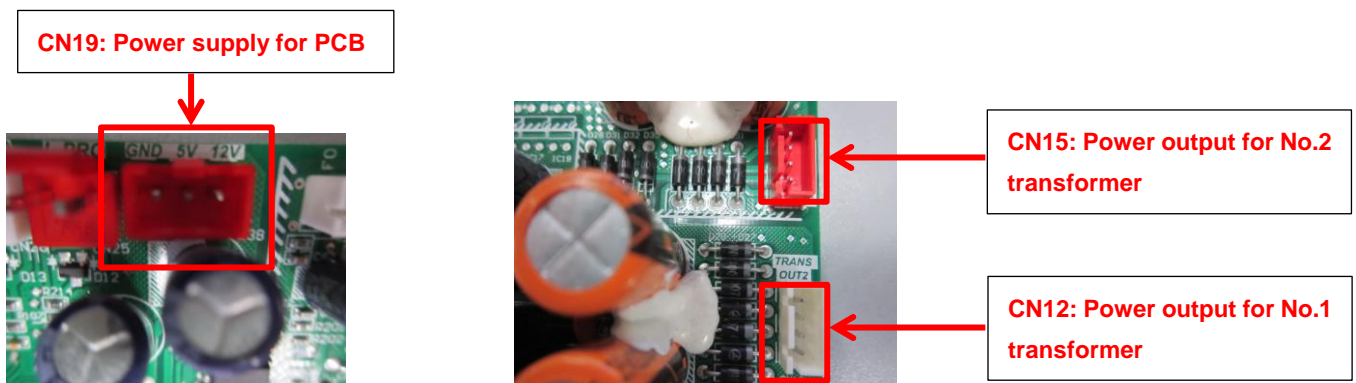

4.9 H2/H3

H2: Quantity of outdoor units decrease error (Only display on master unit, all the ODU in standby)

H3: Quantity of outdoor units increase error (Only display on master unit, all the ODU in standby)

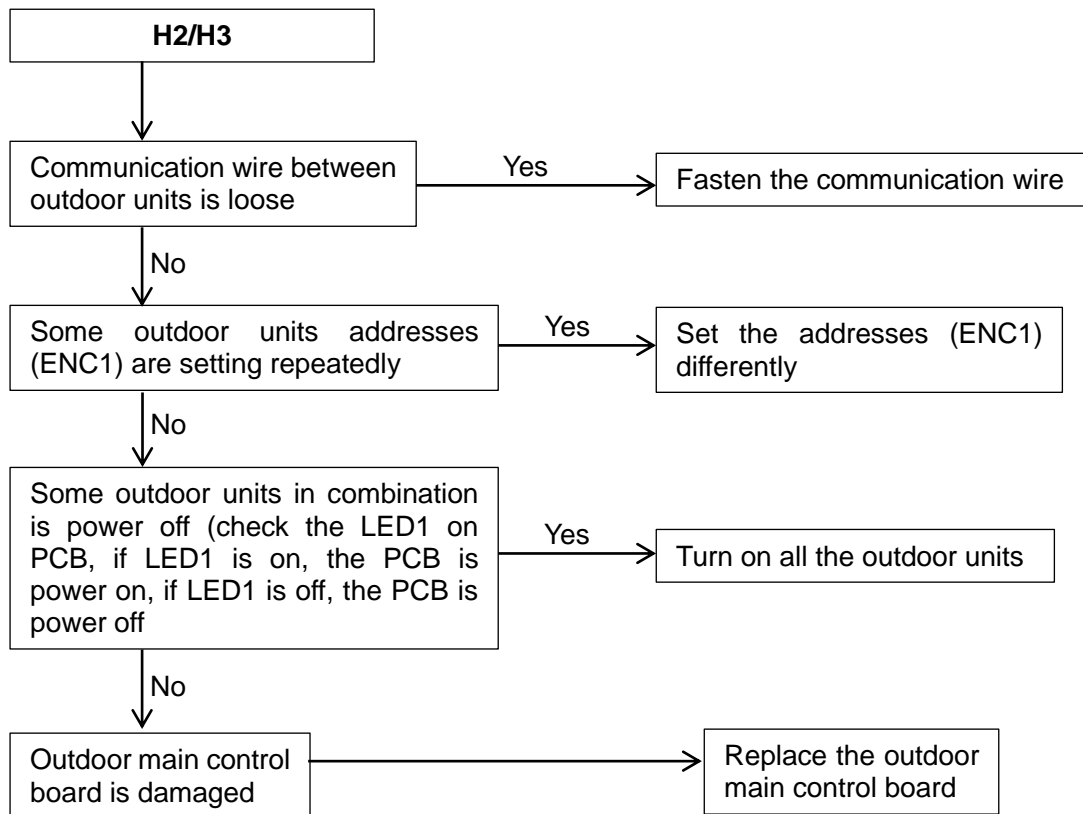

Note: All the outdoor units should be unified power supply. If the outdoor units are not unified power supply, once some outdoor unit is power off, other outdoor units are still running, it may cause system unbalance and damage devices.

4.10 HC: Outdoor unit capacity setting error

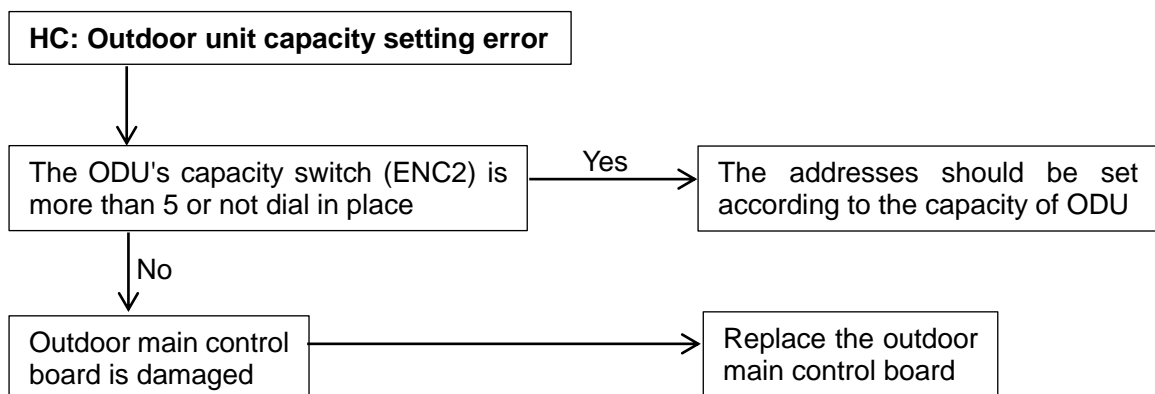

4.11 H7: Quantity of indoor units decrease error (Only display on master unit, all the ODU in standby)

“H7” error will display when the quantity of indoor units decrease above 3 minutes.

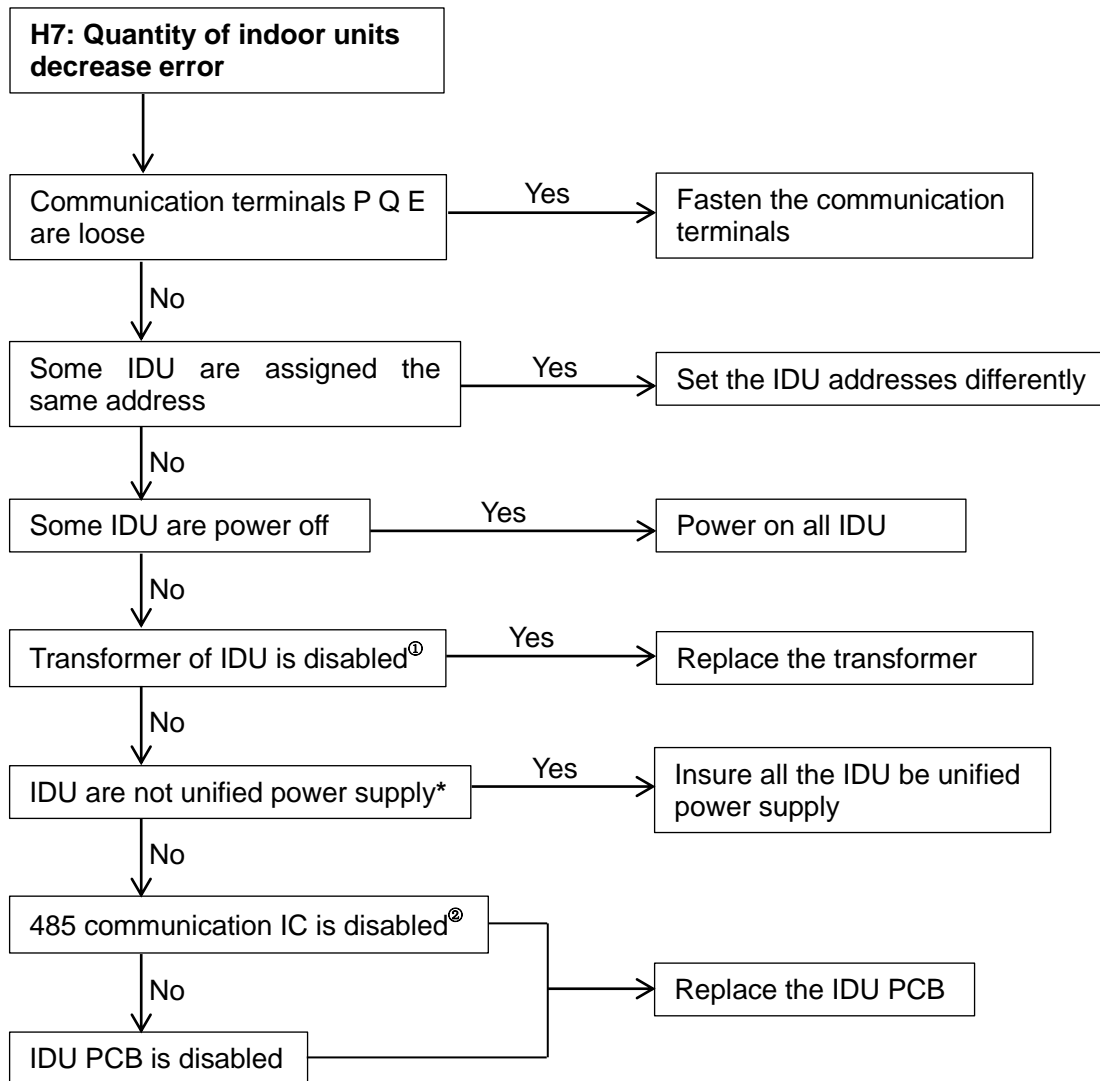
**Note:****1. How to check whether the transformer of IDU is disabled^①**

The voltage input for IDU transformer is 220V, the voltage output of is AC9V (yellow-yellow) and AC13.5V (brown-brown)

2. How to check whether the 485 communication IC is disabled^②

The normal voltage between “P” and “GND” is DC2.5~2.7V, between “Q” and “GND” is DC2.5~2.7V. If the voltage is out of the normal range, the 485 communication IC is disabled.

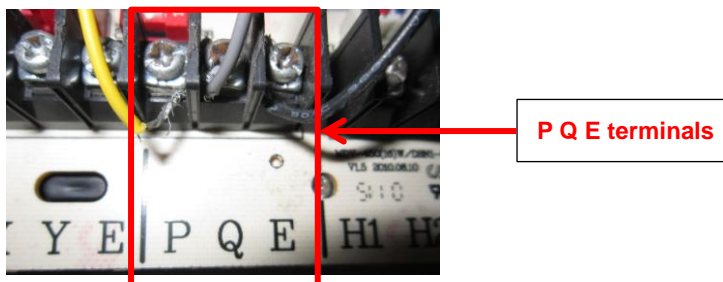

*Indoor units should be unified power supply, which can prevent compressor from liquid hammer caused by dropped indoor units with EXV unclosed.

4.12 P0/P4/H6: High temperature protection (Display on faulty unit, all the ODU in standby)

P0: Top temperature protection of inverter compressor

When the top temperature is over 120°C, the operation will stop, when the temperature goes back to normal range, P0 disappear and normal operation resumes.

P4: Discharge temperature protection of all compressors

When the discharge temperature of any compressor is over 120°C, the operation will stop, when the temperature goes back to normal range, P4 disappear and normal operation resumes.

H6: When system appear 3 times P4 protection in 100 minutes

It cannot resume automatically, and it can resume only by restarting the machine.

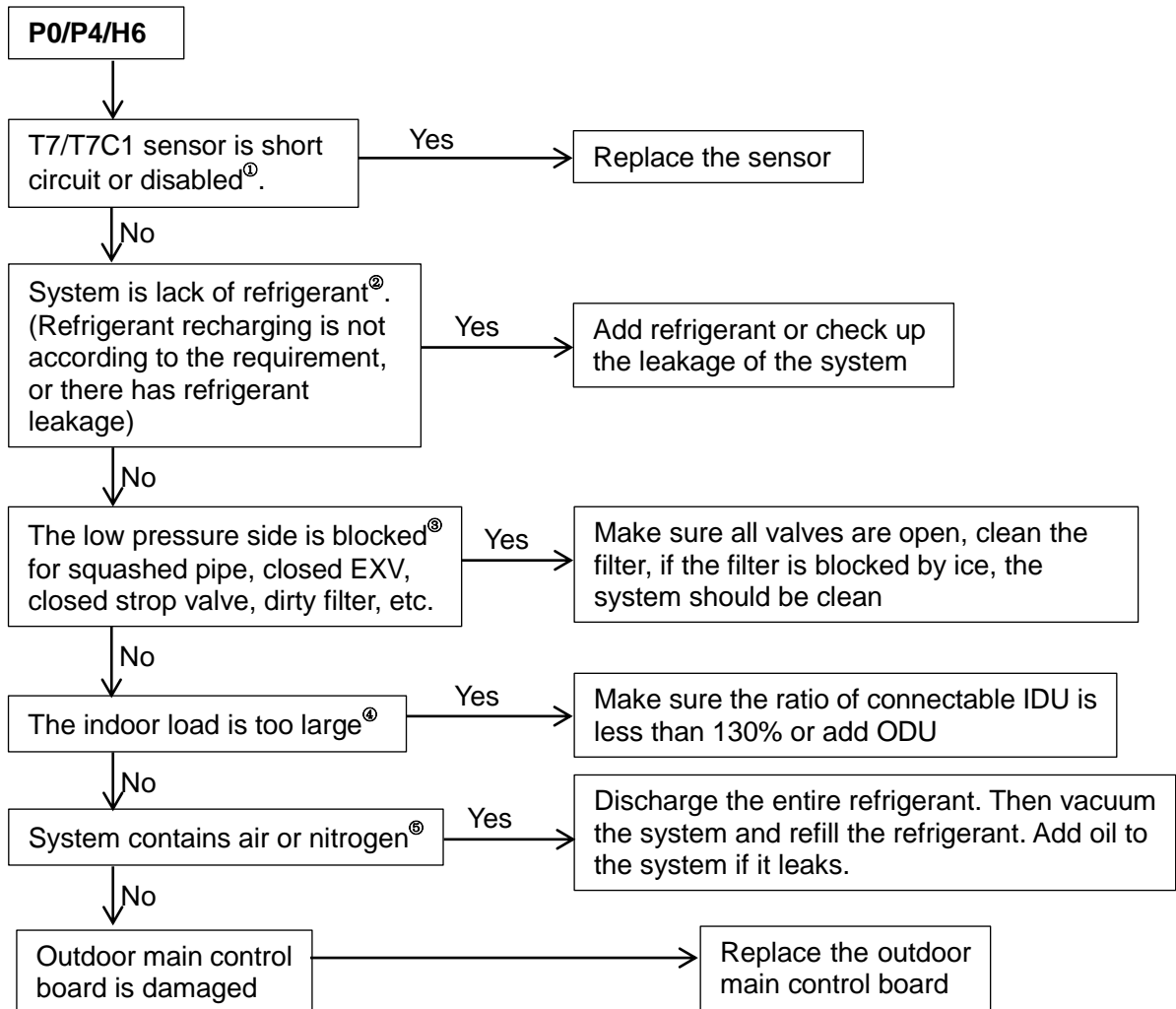

Note:

1. How to check whether the T7/T7C1 sensor is short circuit or disabled:

Using a multimeter to measure resistance, if the resistance is too small, the sensor is short circuit, if the resistance in certain temperature is not consistent with attached table 2, the sensor is disabled

2. The phenomenon of lack of refrigerant:

Top temperature and discharge temperature of all compressors are higher than normal value, discharge pressure and suction pressure are both lower than normal value, current is lower than normal value, suction pipe may be frosting. All the phenomenon will disappear after recharging refrigerant.

3. The phenomenon of the low pressure side is blocked:

The discharge temperature is higher than normal value*, low pressure is lower than normal value*, current is lower than normal value* and suction pipe may be frosting.

4. The phenomenon of the indoor load is too large:

The suction temperature and discharge temperature are both higher than normal value.

5. The phenomenon of the system contains air or nitrogen:

The high pressure is higher than normal value, current is larger than normal value, discharge temperature is higher than normal value, compressor makes noise, pressure meter do not display steady.

*The normal system running parameters please refer to attached table 3.

4.13 P1: High pressure protection (Display on faulty unit, all the ODU in standby)

When the pressure is over 4.4MPa, the system will display P1 protection, all the ODU in standby. When the pressure is lower than 3.2MPa, P1 disappears and normal operation resumes.

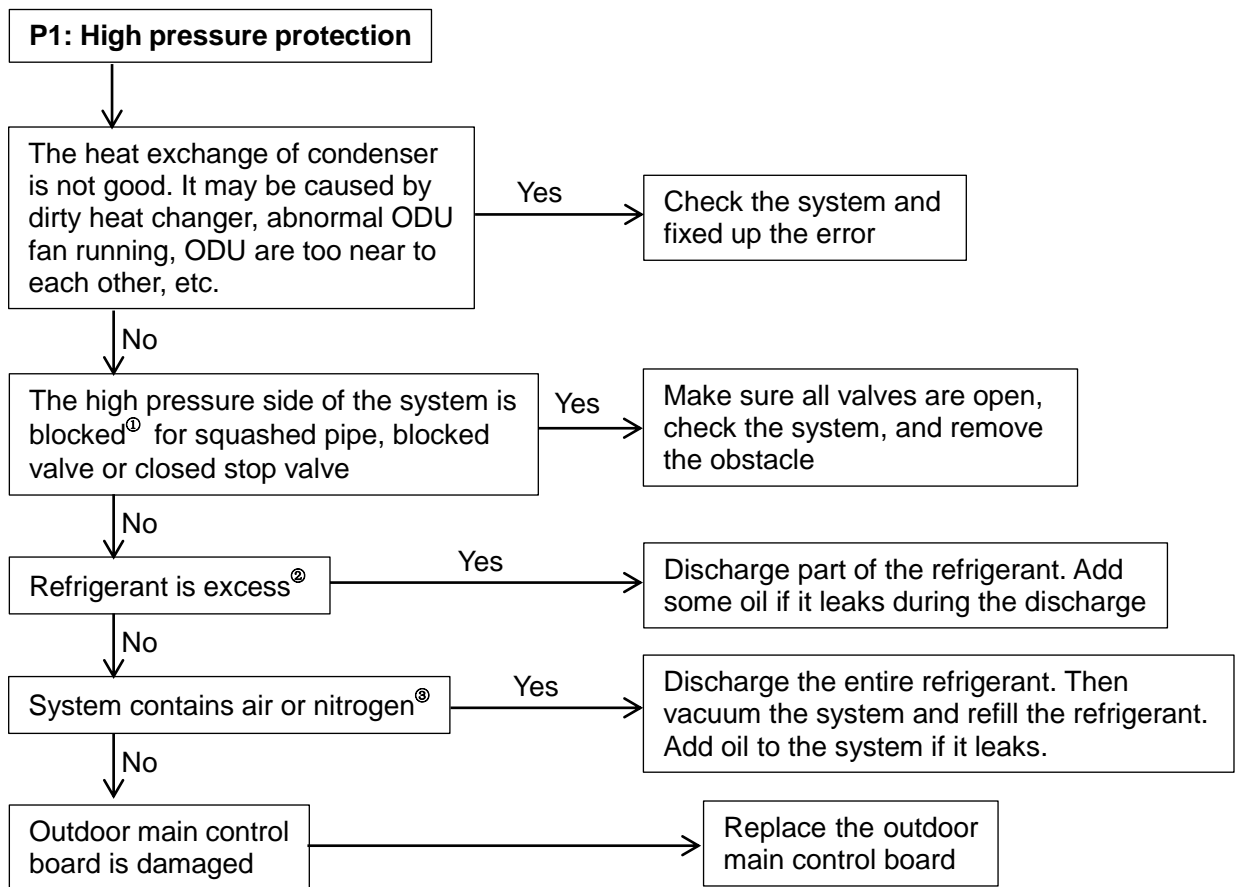

Note:

1. The phenomenon of the high pressure side of the system is blocked[Ⓢ]:

The high pressure is higher than normal value, the low pressure is lower than normal value, and the discharge temperature is higher than normal value.

2. The phenomenon of the refrigerant is excess[Ⓢ]:

The high pressure is higher than normal value, the low pressure is higher than normal value, and the discharge temperature is lower than normal value.

3. The phenomenon of the system contains air or nitrogen[Ⓢ]:

The high pressure is higher than normal value, current is larger than normal value, discharge temperature is higher than normal value, compressor makes noise, pressure meter do not display steady.

*The normal system running parameters please refer to attached table 3.

*If the system install three-phase protector, and the three-phase protector connect with high pressure switch in series connection, the system will display P1 protection when fist power on, and P1 protection will disappear after system is steady.

*If the system install three-phase protector, and the three-phase protector connect with low pressure switch in series connection, the system will display P2 protection when fist power on, and P2 protection will disappear after system is steady.

4.14 P2/H5: Low pressure protection (Display on faulty unit, all the ODU in standby)

When the pressure is lower than 0.05MPa, the system will display P2 protection, all the ODU in standby. When the pressure is higher than 0.15MPa, P2 disappear and resumes normal operation.

H5 error will display when system appear 3 times P2 protection in 30 minutes, it cannot resume automatically, and it can resume only by restarting the machine.

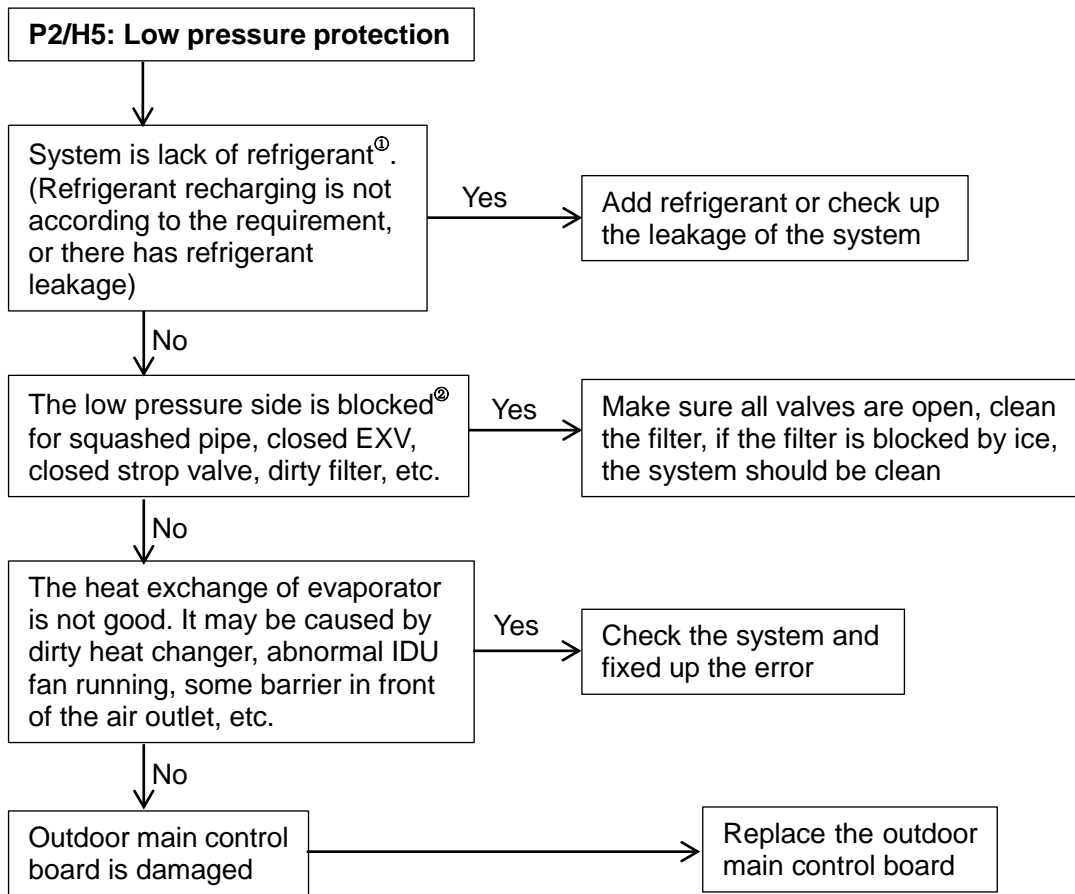

Note:

1. The phenomenon of lack of refrigerant[Ⓢ]:

Top temperature and discharge temperature of all compressors are higher than normal value, discharge pressure and suction pressure are both lower than normal value, current is lower than normal value, suction pipe may be frosting. All the phenomenon will disappear after recharging refrigerant.

2. The phenomenon of the low pressure side is blocked[Ⓢ]:

The discharge temperature is higher than normal value*, low pressure is lower than normal value*, current is lower than normal value* and suction pipe may be frosting.

*The normal system running parameters please refer to attached table 3.

*If the system install three-phase protector, and the three-phase protector connect with high pressure switch in series connection, the system will display P1 protection when fist power on, and P1 protection will disappear after system is steady.

*If the system install three-phase protector, and the three-phase protector connect with low pressure switch in series connection, the system will display P2 protection when fist power on, and P2 protection will disappear after system is steady.

4.15 P3/P7: Compressor current protection (Display on faulty unit, all the ODU in standby)

P3: Current protection of inverter compressor

When the current of inverter compressor is over 12A, the system will display P3 protection, all the ODU in standby. When the current goes back to normal range, P3 disappear and normal operation resumes.

P7: Current protection of fixed compressor

When the current of fixed compressor is over 17A, the system will display P7 protection, all the ODU in standby. When the current goes back to normal range, P7 disappear and normal operation resumes.

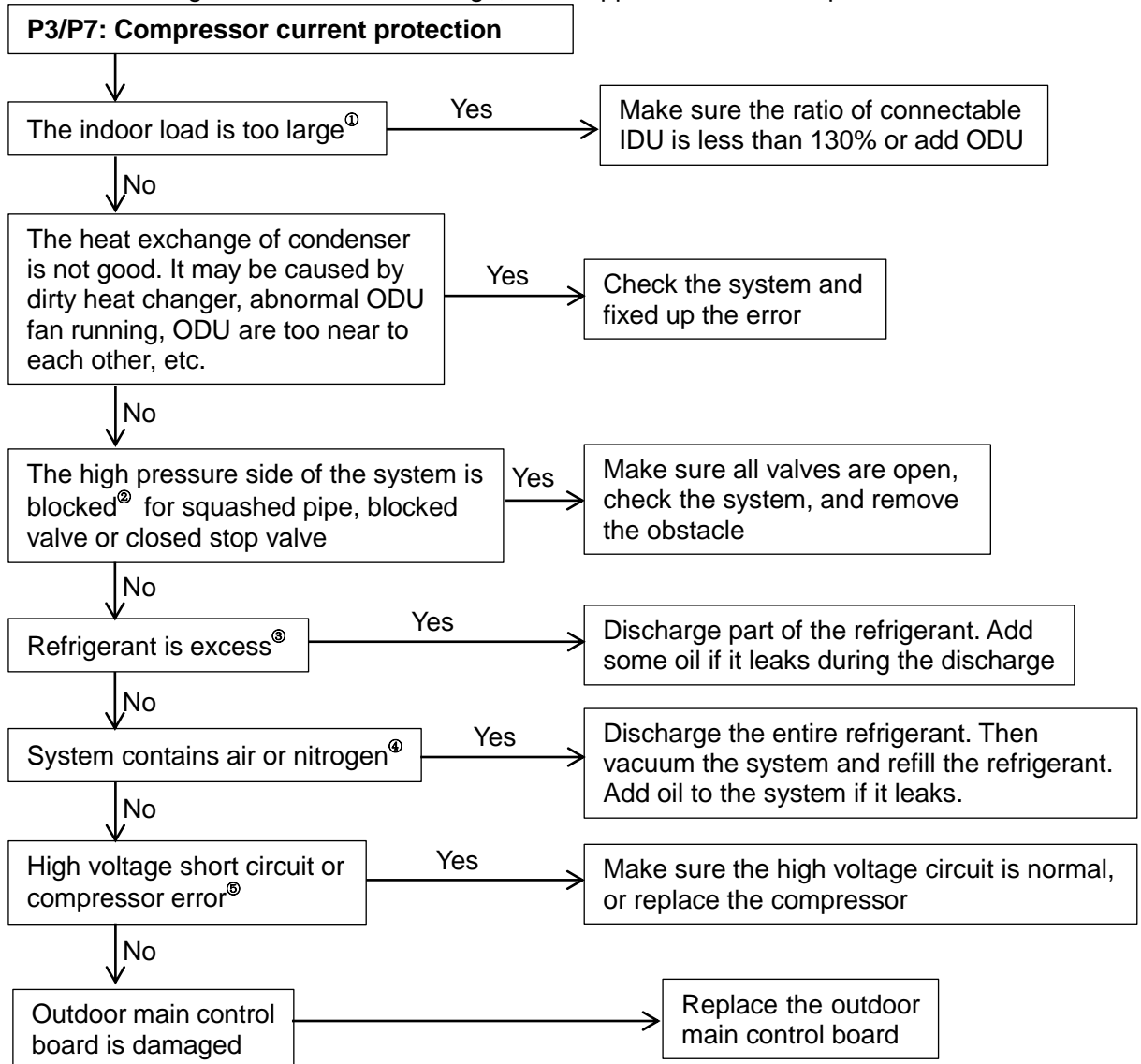

Note:

1. The phenomenon of the indoor load is too large[®]:

The suction temperature and discharge temperature are both higher than normal value.

2. The phenomenon of The high pressure side of the system is blocked[®]:

The high pressure is higher than normal value, the low pressure is lower than normal value, and the discharge temperature is higher than normal value.

3. The phenomenon of the refrigerant is excess[®]:

The high pressure is higher than normal value, the low pressure is higher than normal value, and the discharge temperature is lower than normal value.

4. The phenomenon of the system contains air or nitrogen[®]:

The high pressure is higher than normal value, current is larger than normal value, discharge temperature is higher than normal value, compressor makes noise, pressure meter do not display steady.

5. How to check whether compressor is error[®]:

Measure the resistance between two terminals among the three terminals of compressor. The resistance between two terminals is 2-5Ω, the resistance between each terminal and ground is infinity, if the resistance is out of the normal range, the compressor is error.

*The normal system running parameters please refer to attached table 3.

4.16 P5: Condenser temperature T3 protection (Display on faulty unit, all the ODU in standby)

When condenser temperature is over 65°C, the system will display P5 protection, all the ODU in standby. When the temperature goes back to normal range, P5 disappear and normal operation resumes.

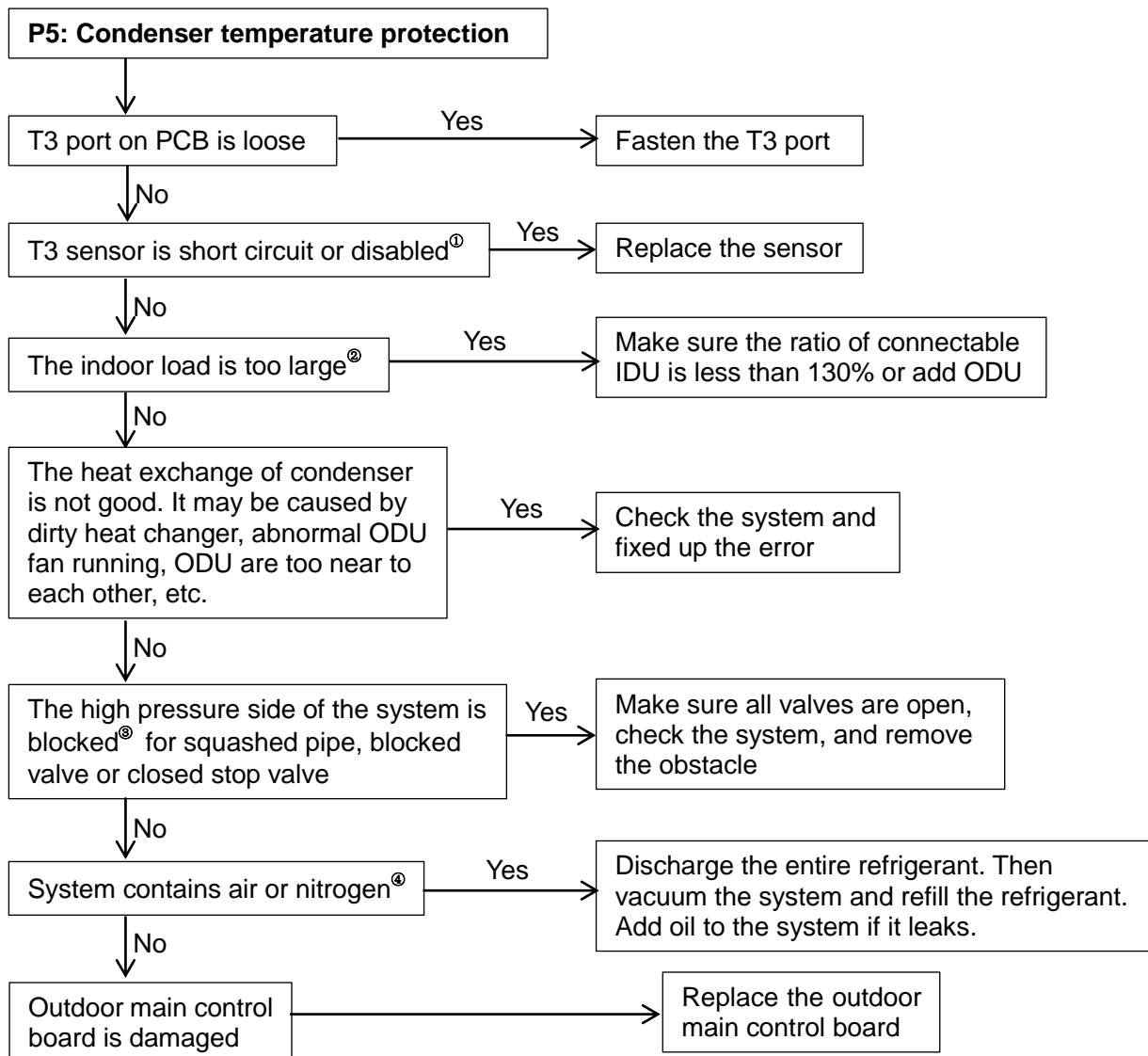

Note:

1. How to check whether the T3 sensor is circuit or disabled^①:

Using a multimeter to measure resistance, if the resistance is too small, the sensor is short circuit, if the resistance in certain temperature is not consistent with attached table 1, the sensor is disabled

2. The phenomenon of the indoor load is too large^②:

The suction temperature and discharge temperature are both higher than normal value.

3. The phenomenon of The high pressure side of the system is blocked^③:

The high pressure is higher than normal value, the low pressure is lower than normal value, and the discharge temperature is higher than normal value.

4. The phenomenon of the system contains air or nitrogen^④:

The high pressure is higher than normal value, current is larger than normal value, discharge temperature is higher than normal value, compressor makes noise, pressure meter do not display steady.

4.17 P6/H4: Inverter module protection (Display on faulty unit, all the ODU in standby)

If the system display three times P6 protection in 30 minutes, the system will stop and display H4 error code. When the system displays H4 error code, the system can resume only by restarting the machine. At this time, malfunction should be disposed promptly to avoid further damage.

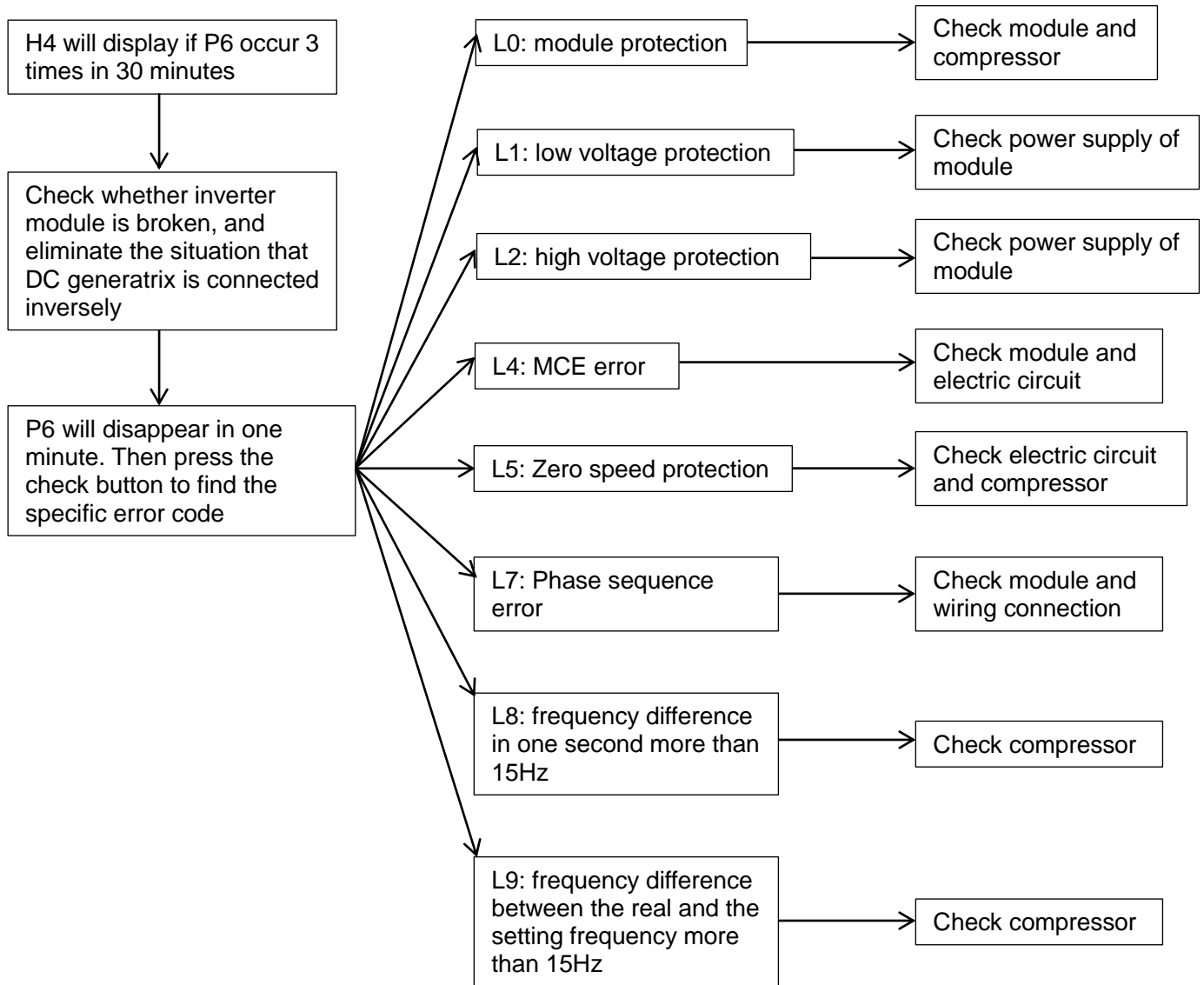

DC generatrix check

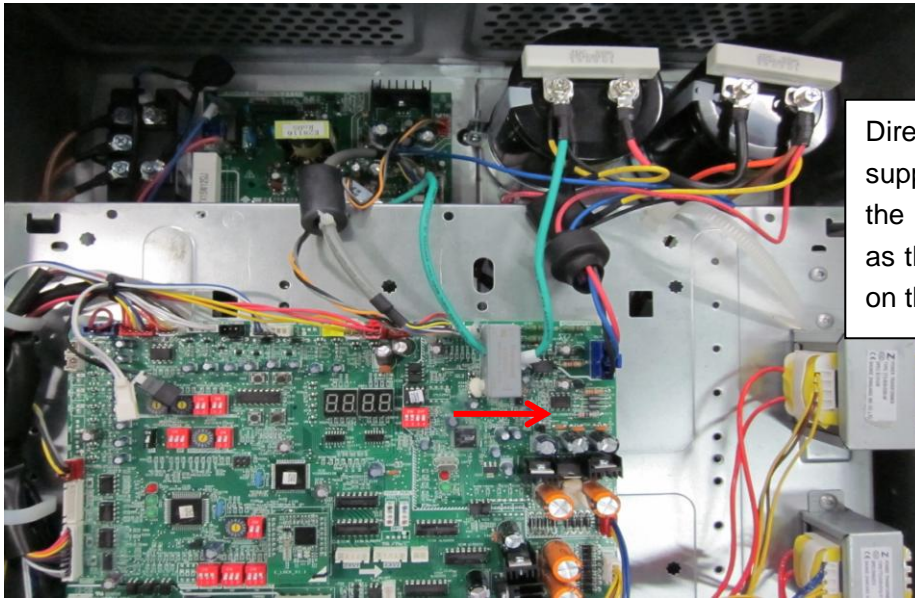

Direction of the current in DC supply wire is running through the inductor should be the same as the direction of arrow marked on the inductor

- 1) Check the voltage of DC generatrix, the normal value should be 510 to 580V. If the value is less than 510V, go to next step.
- 2) Check the wiring connection of rectifier circuit, find out any loose in the circuit, and check the filter board, single-phase rectifier stack, and three-phase rectifier stack. Note DC and AC switch in the measurement.
- 3) If none of the above works, replace the PCB.

Module check

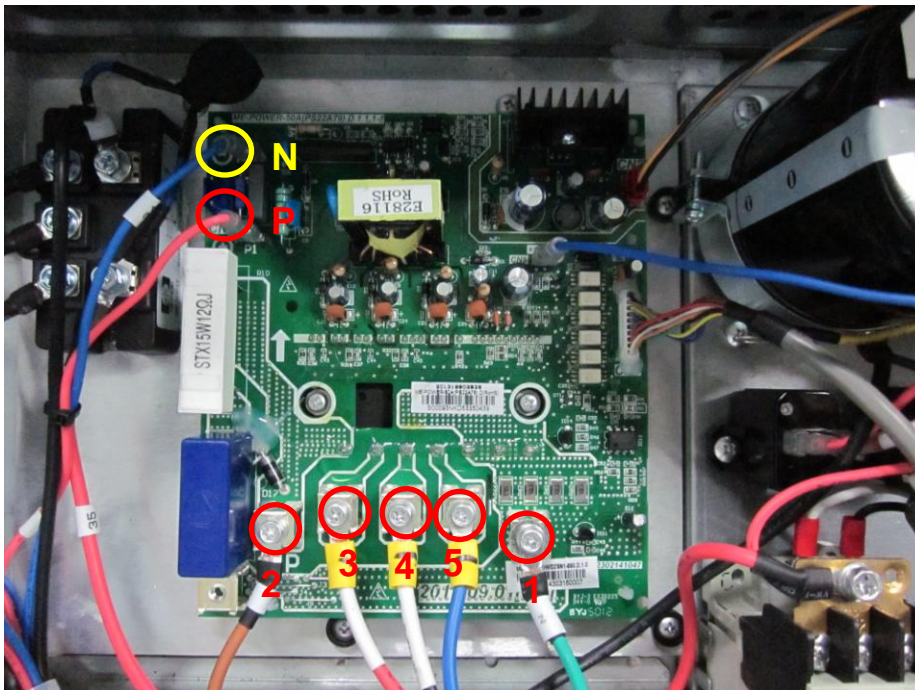

- 1) DC voltage between P and N should be about 1.41 times of the local power supply voltage.
- 2) DC voltage between 1 and 2 should be 510V to 580V
- 3) First adjust multi-meter to diode position, put the red pen on the 1 point (N terminal), put black pen on the 3 or 4 or 5 point, the value should be approximate 0.378, if the value is 0, the IPM is broken. And then change the red pen to the 2 point (P terminal), the value should be infinity, if the value is 0, the IPM is broken.

4.17.1 L0/L8/L9 troubleshooting

Step 1: Replace the modular with correctly wire connection and start the system, if system is still malfunction, then go to step 2 to check the compressor.

Step 2: Take out the compressor from the malfunction system, short-circuit the suction and the discharge, vacuum dry and charge 0.3kg~0.4kg R410A, and then connect the U,V,W terminals to control box B which is took apart from normal system.

If the compressor start normally, that means compressor is OK, control box A is malfunction, then check the inverter module.

If the compressor could not start normally, that means the compressor is malfunction, then go to step 3 to check the compressor.

Step 3: Check the compressor

Measure the resistance between each two of U, V, W terminals, all the resistance should be the same and equal to 0.9~5 Ohms. (Fig. A and Fig. B)

Measure the resistance between each of U, V, W terminals to ground (Fig. C), all the resistance should be the same and trend to be infinity (Fig. D), otherwise the compressor has been malfunction, needs to be replaced.



Fig. A



Fig. B



Fig. C



Fig. D

4.17.2 L1/L4 troubleshooting

Step 1: Check the DC voltage between P and N terminal, the normal value should be 510V~580V, if the voltage is lower than 510V, go to step 2.

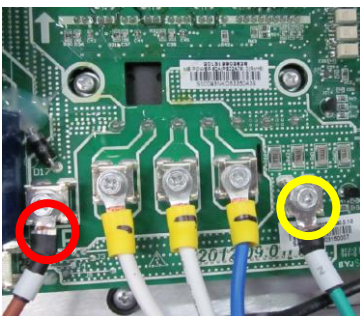

Step 2: Check whether the wires of rectifier circuit are loose or not. If wires are loosen, fasten the wires. If wires are OK, replace the PCB.

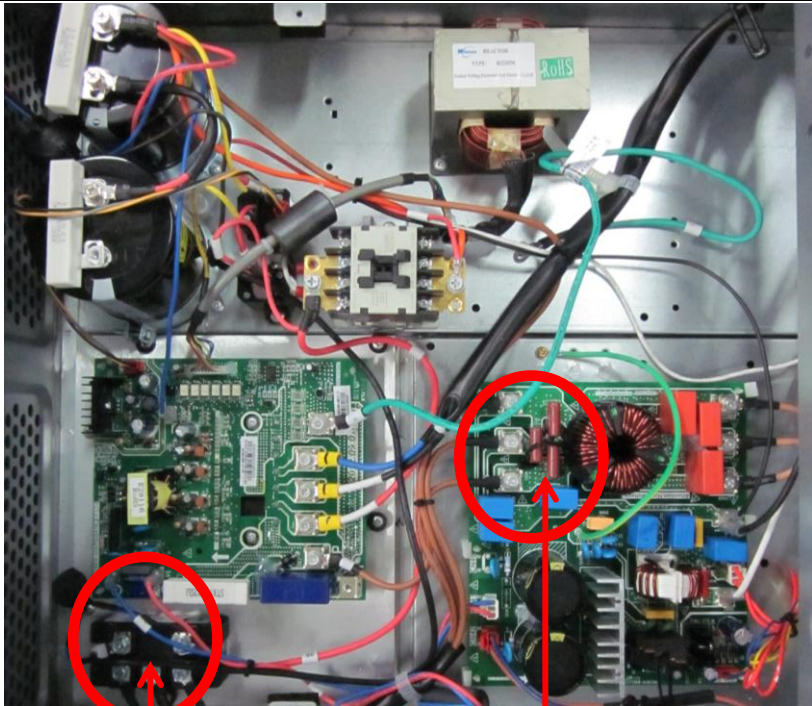

**3-Phase
rectifier stack**

**Filter
board**

4.17.3 L2 troubleshooting

Step 1: Check the DC voltage between P and N terminal, the normal value should be 510V-580V, if the voltage is higher than 580V, go to step 2.

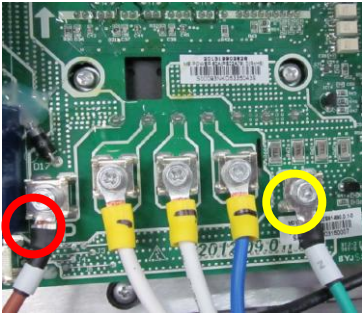

Step 2: Check the voltage between two electrolytic capacitors, the normal value should be 510V-580V, if not in the range then the PCB has malfunction, it needs to be replaced.

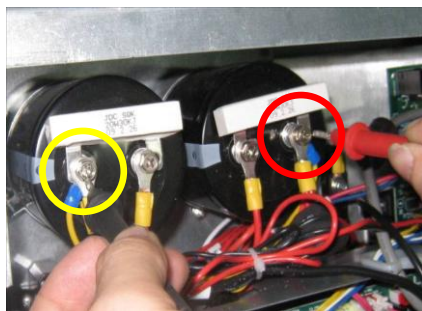

Turn the measure range of the meter to 1kV and measure the voltage between two electrolytic capacitors



4.18 P9/H9: Fan module protection (Display on faulty unit, all the ODU in standby)

If the system display three times P9 protection in 30 minutes, the system will stop and display H9 error code. When the system displays H9 error code, the system can resume only by restarting the machine. At this time, malfunction should be disposed promptly to avoid further damage.

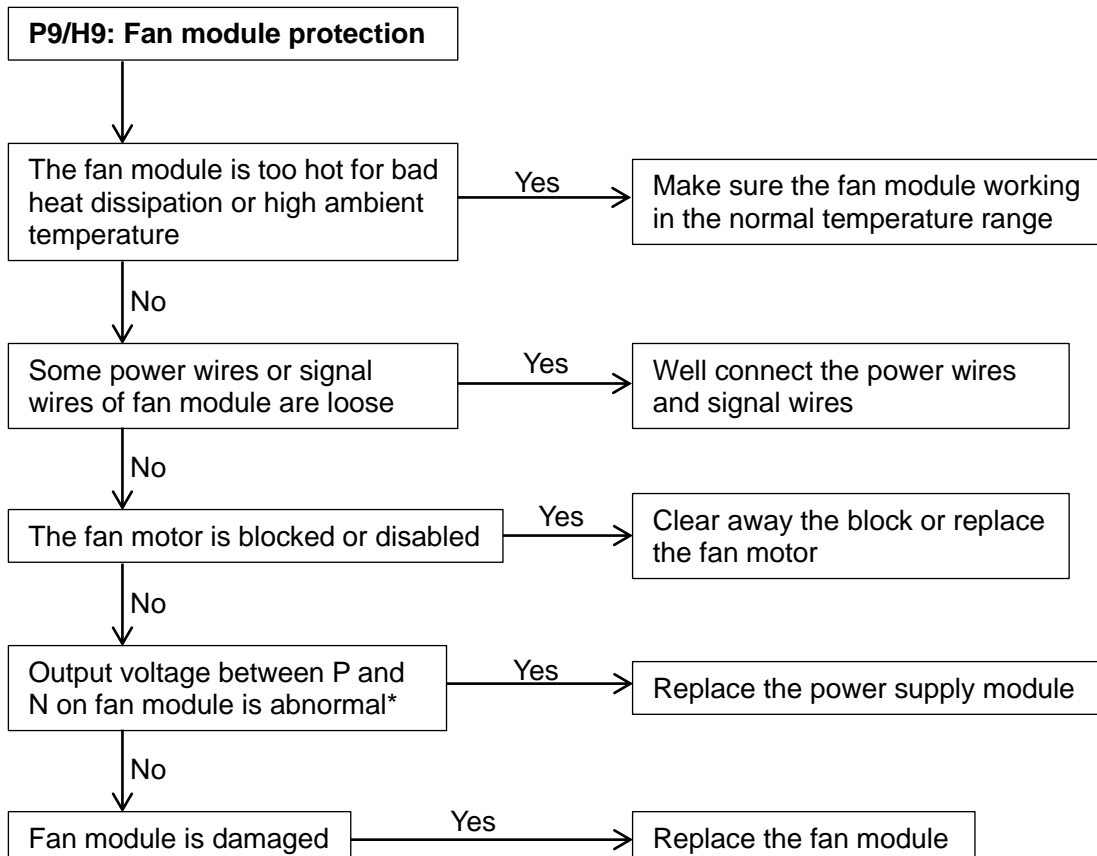

Fan module instruction

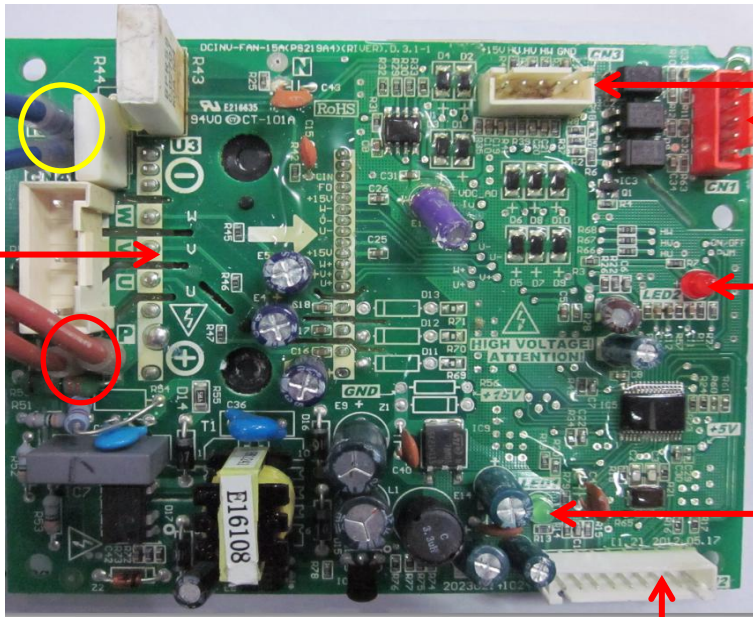

- 1 Program input port
- 2 Power supply indicator lamp
- 3 Fan motor U, V, W output port
- 4 Fault indicator lamp
- 5 PCB control signal input port
- 6 Signal feedback port

* The normal value of output voltage between P and N on fan module is DC 310V

P9 protection analysis

Conditions	Fault indicator lamp of fan module	Power supply indicator lamp of fan module	Digital tube display	Malfunction analysis
Power on	Off	Off	Quantity of IDU or "0"	Check the power supply circuit for fan module. Check whether there has power supply for lightning protection plate, whether the protective tube is broken, whether the voltage after rectification is normal, whether the bridge rectifier is broken.
Power on	Off	Flicker	Quantity of IDU or "0"	Power supply of fan module has problem, needs to replace the fan module.
When fan motor start	At first the lamp is on then the lamp is off	On	P9/H9	Check whether the drive port and signal feedback port is loose, whether the fan module and fan motor is installed firmly. If above conditions are all OK, it needs to replace the fan module.
When fan motor start	At first the lamp is on then the lamp flicker	On	P9/H9	Check whether the transformer in lightning protection plate is open circuit, whether the relay is broken. If occurs above problem, it needs to replace the lightning protection plate.
Fan motor running several minutes	On	On	P9/H9	Check whether the capacity setting from dial switch is accordance with actual ODU capacity, whether the capacity from spot check is accordance with actual ODU capacity. If occurs above problem, it needs to adjust the capacity setting. If above conditions are both OK, it needs to replace the PCB.

Attached table 1:**Resistance value of ambient temperature and pipe temperature sensor**

Temperature (°C)	Resistance value (kΩ)	Temperature (°C)	Resistance value (kΩ)	Temperature (°C)	Resistance value (kΩ)	Temperature (°C)	Resistance value (kΩ)
-20	115.266	20	12.6431	60	2.35774	100	0.62973
-19	108.146	21	12.0561	61	2.27249	101	0.61148
-18	101.517	22	11.5	62	2.19073	102	0.59386
-17	96.3423	23	10.9731	63	2.11241	103	0.57683
-16	89.5865	24	10.4736	64	2.03732	104	0.56038
-15	84.219	25	10	65	1.96532	105	0.54448
-14	79.311	26	9.55074	66	1.89627	106	0.52912
-13	74.536	27	9.12445	67	1.83003	107	0.51426
-12	70.1698	28	8.71983	68	1.76647	108	0.49989
-11	66.0898	29	8.33566	69	1.70547	109	0.486
-10	62.2756	30	7.97078	70	1.64691	110	0.47256
-9	58.7079	31	7.62411	71	1.59068	111	0.45957
-8	56.3694	32	7.29464	72	1.53668	112	0.44699
-7	52.2438	33	6.98142	73	1.48481	113	0.43482
-6	49.3161	34	6.68355	74	1.43498	114	0.42304
-5	46.5725	35	6.40021	75	1.38703	115	0.41164
-4	44	36	6.13059	76	1.34105	116	0.4006
-3	41.5878	37	5.87359	77	1.29078	117	0.38991
-2	39.8239	38	5.62961	78	1.25423	118	0.37956
-1	37.1988	39	5.39689	79	1.2133	119	0.36954
0	35.2024	40	5.17519	80	1.17393	120	0.35982
1	33.3269	41	4.96392	81	1.13604	121	0.35042
2	31.5635	42	4.76253	82	1.09958	122	0.3413
3	29.9058	43	4.5705	83	1.06448	123	0.33246
4	28.3459	44	4.38736	84	1.03069	124	0.3239
5	26.8778	45	4.21263	85	0.99815	125	0.31559
6	25.4954	46	4.04589	86	0.96681	126	0.30754
7	24.1932	47	3.88673	87	0.93662	127	0.29974
8	22.5662	48	3.73476	88	0.90753	128	0.29216
9	21.8094	49	3.58962	89	0.8795	129	0.28482
10	20.7184	50	3.45097	90	0.85248	130	0.2777
11	19.6891	51	3.31847	91	0.82643	131	0.27078
12	18.7177	52	3.19183	92	0.80132	132	0.26408
13	17.8005	53	3.07075	93	0.77709	133	0.25757
14	16.9341	54	2.95896	94	0.75373	134	0.25125
15	16.1156	55	2.84421	95	0.73119	135	0.24512
16	15.3418	56	2.73823	96	0.70944	136	0.23916
17	14.6181	57	2.63682	97	0.68844	137	0.23338
18	13.918	58	2.53973	98	0.66818	138	0.22776
19	13.2631	59	2.44677	99	0.64862	139	0.22231

Attached table 2:**Resistance value of compressor discharge temperature sensor**

Temperature (°C)	Resistance value (kΩ)	Temperature (°C)	Resistance value (kΩ)	Temperature (°C)	Resistance value (kΩ)	Temperature (°C)	Resistance value (kΩ)
-20	542.7	20	68.66	60	13.59	100	3.702
-19	511.9	21	65.62	61	13.11	101	3.595
-18	483	22	62.73	62	12.65	102	3.492
-17	455.9	23	59.98	63	12.21	103	3.392
-16	430.5	24	57.37	64	11.79	104	3.296
-15	406.7	25	54.89	65	11.38	105	3.203
-14	384.3	26	52.53	66	10.99	106	3.113
-13	363.3	27	50.28	67	10.61	107	3.025
-12	343.6	28	48.14	68	10.25	108	2.941
-11	325.1	29	46.11	69	9.902	109	2.86
-10	307.7	30	44.17	70	9.569	110	2.781
-9	291.3	31	42.33	71	9.248	111	2.704
-8	275.9	32	40.57	72	8.94	112	2.63
-7	261.4	33	38.89	73	8.643	113	2.559
-6	247.8	34	37.3	74	8.358	114	2.489
-5	234.9	35	35.78	75	8.084	115	2.422
-4	222.8	36	34.32	76	7.82	116	2.357
-3	211.4	37	32.94	77	7.566	117	2.294
-2	200.7	38	31.62	78	7.321	118	2.233
-1	190.5	39	30.36	79	7.086	119	2.174
0	180.9	40	29.15	80	6.859	120	2.117
1	171.9	41	28	81	6.641	121	2.061
2	163.3	42	26.9	82	6.43	122	2.007
3	155.2	43	25.86	83	6.228	123	1.955
4	147.6	44	24.85	84	6.033	124	1.905
5	140.4	45	23.89	85	5.844	125	1.856
6	133.5	46	22.89	86	5.663	126	1.808
7	127.1	47	22.1	87	5.488	127	1.762
8	121	48	21.26	88	5.32	128	1.717
9	115.2	49	20.46	89	5.157	129	1.674
10	109.8	50	19.69	90	5	130	1.632
11	104.6	51	18.96	91	4.849		
12	99.69	52	18.26	92	4.703		
13	95.05	53	17.58	93	4.562		
14	90.66	54	16.94	94	4.426		
15	86.49	55	16.32	95	4.294	B(25/50)=3950K	
16	82.54	56	15.73	96	4.167		
17	78.79	57	15.16	97	4.045	R(90°C)=5KΩ±3%	
18	75.24	58	14.62	98	3.927		
19	71.86	59	14.09	99	3.812		

Attached table 3: Commissioning and operating parameters of refrigerant system

Conditions 1: Make sure outdoor unit can detect all the indoor units, the quantity of indoor units display steadily and be equal to actual quantity of installed indoor units.

Conditions 2: Make sure all the valves in outdoor unit are open, indoor units EXV have connected to indoor PCB.

Conditions 3: The ratio of connectable indoor units is 100%. When ambient temperature is high, operate the system in cooling mode and set the temperature 17°C. When ambient temperature is low, operate the system in heating mode and set the temperature 30°C. Then get the parameters after system running normally more than 30 minutes.

Outdoor unit cooling parameters table

Ambient temperature (T4)	°C	20-27	27-33	33-38	38-45
Discharge pressure (spot check)	MPa	2.1-2.3	2.8-3.1	3.3-3.5	3.7-3.9
Pressure of high pressure valve	MPa	1.8-2.0	2.4-2.7	2.8-3.0	3.2-3.5
Pressure of low pressure valve	MPa	0.7-0.9	0.8-1.0	1.0-1.2	1.2-1.4
Discharge temperature (spot check)	°C	50-65	70-85	70-90	80-90
DC Inverter compressor current (spot check)	A	4-5	6-7	7-8	9-11
Fixed compressor current (spot check)	A	6-7	8-9	9-11	11-12
Average temperature of evaporator outlet T2B	°C	8-9	12-15	16-17	20

Outdoor unit heating parameters table

Ambient temperature (T4)	°C	-15--5	-5-5	5-12	12-18
Discharge pressure (spot check)	MPa	2.0-2.2	2.2-2.7	3.0-3.1	2.6-2.7
Pressure of high pressure valve	MPa	1.7-1.8	1.8-2.4	2.6-2.8	2.1-2.4
Pressure of low pressure valve	MPa	2.0-2.2	2.2-2.6	3.0-3.1	2.5-2.7
Discharge temperature (spot check)	°C	50-70	60-70	60-85	60-70
DC Inverter compressor current (spot check)	A	5	5-6	6-8	5-6
Fixed compressor current (spot check)	A	6	6-7	9-10	8-9
Average temperature of condenser outlet T2	°C	33	33-40	46-50	39-41